

NEW

SB[®] Environmental Boots



The soft shell boots provide water, dirt, chemical and UV protection for SB[®] connectors. The durable boots shield the connectors from water and dirt to IP64 when mated or unmated when the integral cover is used.

SB[®] Environmental Boots are ideal for a wide range of applications including: generators, industrial trucks, bus and coach, road construction, road maintenance, off road, farm and agriculture equipment.

APP
Anderson Power Products[®]

An **IDEAL** Company

| SPECIFICATIONS |

Electrical

Current Rating Amperes	UL 1977	CSA
• SB®50	120	50
• SB®120	240	130
• SB®175	280	175

Material - SB®50, SB®120 and SB®120

- SB® Connector Housing PC
- SB® Connector Housing (CR) * PC/PBT
- SB® Environmental Boot TPE

Flammability Rating

- UL94 V0

UV and Ozone Resistant

Yes

*Chemical Resistant Series

Mechanical - Wire Contacts with Bushings

Environmental Protection

- SB®50, SB®120 and SB®175 IP64

Wire Size Range

- | | AWG | mm ² |
|----------|-----------|-----------------|
| • SB®50 | 16 to 6 | 1.3 to 13.3 |
| • SB®120 | 10 to 1 | 5.3 to 42.4 |
| • SB®175 | 12 to 1/0 | 3.3 to 53.5 |

Operating Temperature

- | | F | C |
|-------------------------------|--------------|--------------|
| • SB® Connector Housing | -4° to 221° | -20° to 105° |
| • SB® Connector Housing (CR)* | -40° to 221° | -40° to 105° |
| • SB® Environmental Boot | -40° to 275° | -40° to 135° |

Mating Cycles

- | | Connector in Boot |
|----------|-------------------|
| • SB®50 | 1,500 |
| • SB®120 | 1,500 |
| • SB®175 | 1,500 |

*Chemical Resistant Series

- IP64 Protection



Totally Protected
Against Dust Ingress



360° Protected
Against Water Ingress

- Resistant to UV, Roadway Chemical and Ozone
- Splash Resistant When Mated and Unmated When the Integral Cover is Used
- Customized Boots to Fit Your AWG or MM² Wires
- Mountable
- Easy to Use

| DIMENSIONS |

Mated Boot Dimensions

Mated Boot Dimensions	- A -		- B -		- C -	
	Inches	mm	Inches	mm	inches	mm
SB®50 Environmental Boot	5.9	151.4	1.8	45.1	6.3	160
SB®120 Environmental Boot	7.9	200	3.1	78	8.0	204
SB®175 Environmental Boot	9.5	241	3.2	80	9.3	236

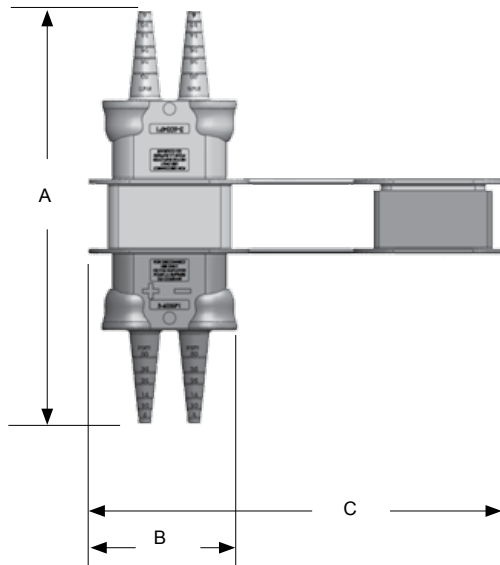

Mated Boots with Covers

SB[®]50 | ORDERING INFORMATION |

SB[®] 50 Environmental Boots

SB[®] Environmental Boots provide water, dirt, chemical and UV protection for SB[®]50 connectors. The durable boots shield the connectors from water and dirt to IP64 in both the mated and unmated condition.

Description	----- Part Numbers -----	
Minimum Quantity	250	25
SB [®] 50 Environmental Boot (no cover), Load	3-6054P1-BK	3-6054P1
SB [®] 50 Environmental Boot (no cover), Source	3-6055P1-BK	3-6055P1
SB [®] 50 Environmental Boot with Cover, Load	3-6054P2-BK	3-6054P2
SB [®] 50 Environmental Boot with Cover, Source	3-6055P2-BK	3-6055P2

SB[®]50 Standard Housings

The smallest SB[®] housings work with wire contacts up to 6 AWG [10 mm²]. Genderless design mates with itself. Mechanical keys are color coded.

Description	---- Part Numbers ----	
Minimum Quantity ...	250	50
Yellow	992G5-BK	992G5
Orange	992G7-BK	992G7
Red	992G1-BK	992G1
Gray	992-BK	992
Blue	992G4-BK	992G4
Green	992G6-BK	992G6
Black	992G2-BK	992G2

NOTE: SB[®]50 Black and Gray housings have the same keying features and can be intermated.

SB[®]50 Chemical Resistant (CR) Housings

Same features as the Standard SB[®]50 but molded in a chemical resistant PBT/ PC blend. Suitable for use to -40°C.

Description	----- Part Numbers -----	
Minimum Quantity	250	50
Red	P992G1-BK	P992G1
Gray	P992-BK	P992
Black	P992G2-BK	P992G2

NOTE: Black and Gray housings have the same keying features and can be intermated

SB[®]50 Silver Plated Wire Contacts

Silver plated contacts offer superior electrical performance and durability up to 10,000 mating cycles.

AWG	mm	Force	--- Part Numbers ---	
Minimum Quantity				
			1000	100
6	13.3	Low	1307-BK	1307
6	13.3	High	5900-BK	5900
8	8.4	High	5952-BK	5952
12 to 10	3.3 to 5.3	Low	5953-BK	5953
12 to 10	3.3 to 5.3	High	5915-BK	5915

SB[®]120 | ORDERING INFORMATION |

SB[®] 120 Environmental Boots

SB[®] Environmental Boots provide water, dirt, chemical and UV protection for SB[®]120 connectors. The durable boots shield the connectors from water and dirt to IP64 in both the mated and unmated condition.

Description	----- Part Numbers -----	
Minimum Quantity	250	25
SB [®] 120 Environmental Boot with Cover, Source	3-6034P1-BK	3-6034P1
SB [®] 120 Environmental Boot with Cover, Load	3-6035P1-BK	3-6035P1

SB[®]120 Standard Housings

The second to smallest SB[®] housings work with wire contacts up to 1 AWG [35 mm²]. Genderless design mates with itself. Mechanical keys are color coded.

Description	---- Part Numbers ----	
Minimum Quantity ...	250	50
Red	6810G3-BK	6810G3
Gray	6810G1-BK	6810G1
Blue	6810G2-BK	6810G2

SB[®]120 Chemical Resistant (CR) Housings

Same features as the Standard SB[®]120 but molded in a chemical resistant PBT/ PC blend. Suitable for use to -40°C.

Description	----- Part Numbers -----	
Minimum Quantity ...	250	50
Red	P6810G3-BK	P6810G3
Gray	P6810G1-BK	P6810G1

SB[®]120 Silver Plated Wire Contacts

Silver plated contacts offer superior electrical performance and durability up to 10,000 mating cycles.

AWG	mm	Force	----- Part Numbers -----		
Minimum Quantity					
			600	500	50
1	42.4	Low	1323G1-BK	-	1323G1
2	33.6	High	-	1319-BK	1319
4	21.1	High	-	1319G4-BK	1319G4
6	13.3	High	-	1319G6-BK	1319G6



SB®175 | ORDERING INFORMATION |

SB® 175 Environmental Boots

SB® Environmental Boots provide water, dirt, chemical and UV protection for SB®175 connectors. The durable boots shield the connectors from water and dirt to IP64 in both the mated and unmated condition.

Description	----- Part Numbers -----	
Minimum Quantity	200	25
SB®175 Environmental Boot with Cover, Source	3-6036P1-BK	3-6036P1
SB®175 Environmental Boot with Cover, Load	3-6037P1-BK	3-6037P1

SB®175 Standard Housings

The second to largest SB® housings work with wire contacts up to 1/0 AWG [50 mm²]. Genderless design mates with itself. Mechanical keys are color coded.

Description	---- Part Numbers ----	
Minimum Quantity ...	200	50
Yellow	943-BK	943
Orange	942-BK	942
Red	949-BK	949
Gray	940-BK	940
Blue	941-BK	941
Black (Keyless)	2-7252G11	-
Brown	940-BK	940

NOTE: SB®175 black is keyless and can be mated with all other colors.

SB®175 Chemical Resistant (CR) Housings

Same features as the Standard SB®175 but molded in a chemical resistant PBT/ PC blend. Suitable for use to -40°C.

Description	---- Part Numbers ----	
Minimum Quantity ...	200	50
Red	P949-BK	P949
Gray	P940-BK	P940

SB®175 Silver Plated Wire Contacts

Silver plated contacts offer superior electrical performance and durability up to 10,000 mating cycles.

AWG	mm	Force	--- Part Numbers ---	
Minimum Quantity			500	50
1/0	53.5	High	1382-BK	1382
1	42.4	High	1347-BK	1347
2	33.6	High	1383-BK	1383
4	21.1	High	1384-BK	1384
6	13.3	High	1348-BK	1348

Tooling

APP® crimp tooling is required for UL & CSA connector compliance. Using unapproved crimp tools will void the connector's warranty. For crimp tool information, see the Powerpole/Multipole catalog or visit www.andersonpower.com

Mounting

Environmental boots can be mounted using such items as a hose clamp, hanger strap and cable tie, which are readily available at industrial supply companies, hardware store and/or automotive parts stores. Mounting methods should be thoroughly evaluated for the end use application.



For More Information About SB® Connectors, SB® Dust Covers and Other SB® Accessories, See Our Powerpole® & Multipole Catalog or Visit www.andersonpower.com

For Information About IP68 Environmentally Sealed Connectors, Please Visit www.andersonpower.com/products/spec-pack-connectors

DS-SBBOOT REV 03 15734

All Data Subject To Change Without Notice "A, SB, Powerpole, SPEC Pak, APP and Anderson Power Products" are registered trademarks of Anderson Power Products.



HEADQUARTERS: Anderson Power Products®, 13 Pratts Junction Road, Sterling, MA 01564-2305 USA T:978-422-3600 F: 978-422-0128 • **EUROPE:** Anderson Power Products® Ltd., Unit 3, Europa Court, Europa Boulevard, Westbrook, Warrington, Cheshire, WA5 7TN United Kingdom T: +44 (0) 1925 428390 F: +44 (0) 1925 520203 • **ASIA / PACIFIC:** IDEAL Anderson Asia Pacific Ltd., Unit 922-928 Topsail Plaza, 11 On Sum Street, Shatin N.T., Hong Kong T:+(852) 2636 0836 F:+(852) 2635 9036 • **CHINA:** IDEAL Anderson Technologies (Shenzhen) Ltd., Block A8 Tantou Western Industrial Park, Songgang Baoan District, Shenzhen, PR. China 518105 T: +(86) 755 2768 2118 F: +(86) 755 2768 2218 • **TAIWAN:** IDEAL Anderson Asia Pacific Ltd., Taiwan Branch, 4F.-2, No.116, Dadun 20th St., Situn District, Taichung City 407, Taiwan (R.O.C.) T: +(886) 4 2310 6451 F:+(886) 4 2310 6460 • www.andersonpower.com