

# SERVICE MANUAL

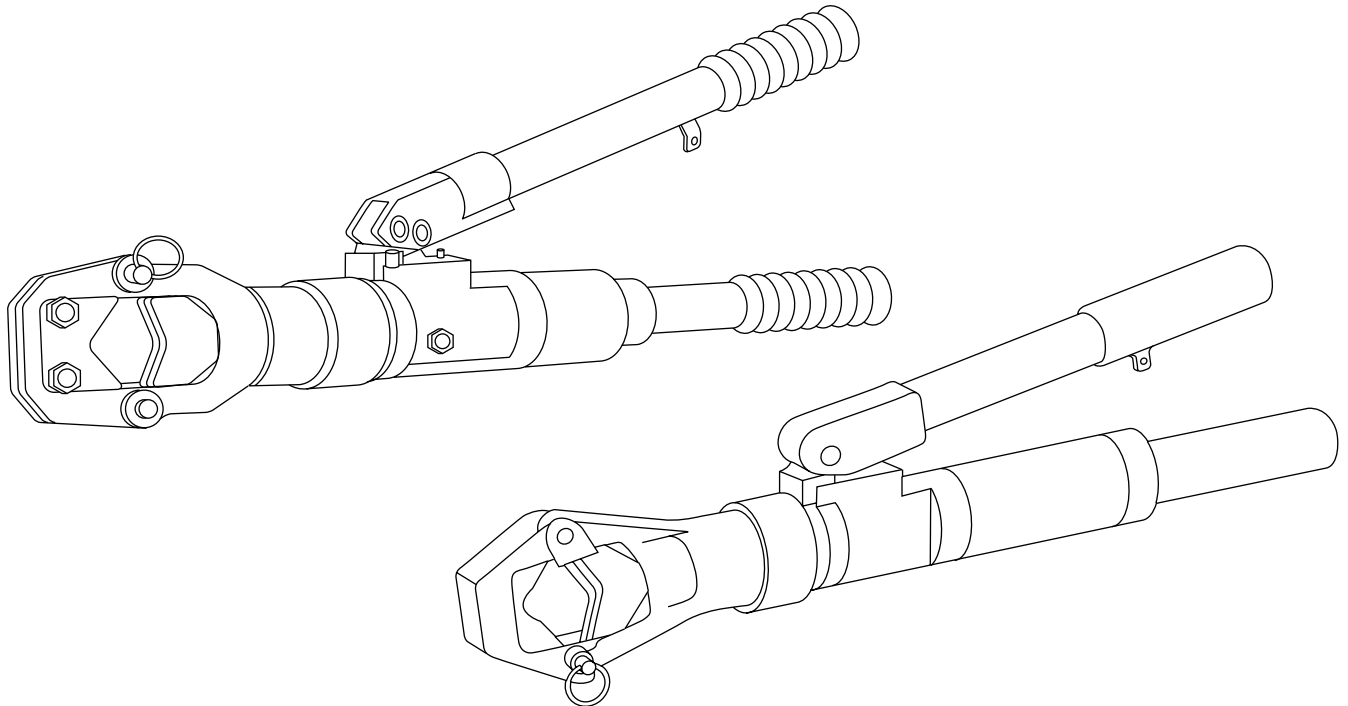

## 1990

# Dieless Hydraulic Crimping Tool

### Serial Codes WH and YM



**Read and understand** all of the instructions and safety information in this manual before operating or servicing this tool.

## Table of Contents

Description .....	2
Safety .....	2
Purpose .....	2
Other Publications .....	2
Important Safety Information .....	3
Identification .....	4
Tools and Supplies .....	5
Pressure Check Procedure .....	5
Pressure Adjustment Procedure .....	6
Pressure Calibration Check .....	7
Air Purging and Oil Filling Procedure .....	8
Die Replacement .....	9
Disassembly .....	10–11
Assembly .....	12–15
Service Tips .....	15
Retrofit Kits .....	16
Troubleshooting .....	17
Illustrations and Parts Lists .....	18–25

## Description

The Greenlee 1990 Dieless Hydraulic Crimping Tool is a self-contained tool intended to crimp copper and aluminum compression connectors. A single set of integral dies provides a wide crimping range.

The Greenlee 1990 is protected by U.S. Patent No. 4,796,461.

## Safety

Safety is essential in the use and maintenance of Greenlee tools and equipment. This manual and any markings on the tool provide information for avoiding hazards and unsafe practices related to the use and maintenance of this tool. Observe all of the safety information provided.

## Purpose

This manual is intended to familiarize authorized Greenlee service center personnel with the safe operation and maintenance procedures for the following Greenlee tools:

- 1990 Serial Code WH
- 1990 Serial Code YM

Keep this manual available to all personnel.

Replacement manuals are available upon request at no charge.

Greenlee and  are registered trademarks of Greenlee Textron.

Dow Corning, Silastic and 732 are registered trademarks of Dow Corning Corporation.

Loctite is a registered trademark of Loctite Corporation.

Univis is a registered trademark of Exxon Corporation.

## Other Publications

Instruction Manuals:

- Serial Code WH: Publication 999 8425.3 (IM-1006)
- Serial Code YM: Publication 999 9994.3 (IM-1093)

**KEEP THIS MANUAL**

**IMPORTANT SAFETY INFORMATION**

	<p><b>SAFETY ALERT SYMBOL</b></p> <p>This symbol is used to call your attention to hazards or unsafe practices which could result in an injury or property damage. The signal word, defined below, indicates the severity of the hazard. The message after the signal word provides information for preventing or avoiding the hazard.</p>
<p><b>⚠ DANGER</b></p>	
<p>Immediate hazards which, if not avoided, <b>WILL</b> result in severe injury or death.</p>	
<p><b>⚠ WARNING</b></p>	
<p>Hazards which, if not avoided, <b>COULD</b> result in severe injury or death.</p>	
<p><b>⚠ CAUTION</b></p>	
<p>Hazards or unsafe practices which, if not avoided, <b>MAY</b> result in injury or property damage.</p>	

	<p><b>⚠ WARNING</b></p> <p>Skin injection hazard: Oil under pressure easily punctures skin causing serious injury, gangrene or death. If you are injured by escaping oil, seek medical attention immediately.</p> <ul style="list-style-type: none"> <li>• Do not use hands to check for leaks.</li> <li>• Depressurize the hydraulic system before servicing.</li> </ul>
--	---

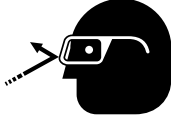
	<p><b>⚠ WARNING</b></p> <p>Wear eye protection when operating or servicing this tool. Failure to wear eye protection can result in serious eye injury from flying debris or hydraulic oil.</p>
--	--

	<p><b>⚠ WARNING</b></p> <p>Pinch points: Keep hands away from closing dies.</p>
--	---

	<p><b>⚠ WARNING</b></p> <p>Electric shock hazard: This tool is not insulated. When using this unit near energized electrical lines, use proper personal protective equipment. Failure to observe this warning can result in severe injury or death.</p>
---	---

	<p><b>⚠ CAUTION</b></p> <ul style="list-style-type: none"> <li>• This tool is intended for two-handed operation. Maintain a firm grip on both handles during operation. Using this tool in any other manner can result in injury or property damage.</li> <li>• Do not operate the tool without dies in place. Damage to the ram or crimping head may result.</li> </ul>
--	--

## Identification

The WH series and YM series crimping tools have several distinguishing characteristics, which are listed here. But be aware that, since many parts are interchangeable, a tool sent to you for repair may be a hybrid — if it has been repaired previously, it may have a mixture of parts from the WH series and YM series.

See Retrofit Kits in this manual for an explanation of interchangeable parts.

Most of the instructions in this service manual apply to both WH series and YM series. However, some individual steps and some procedures apply to only one or the other, and are so noted.

### 1990 Dieless Crimping Tool

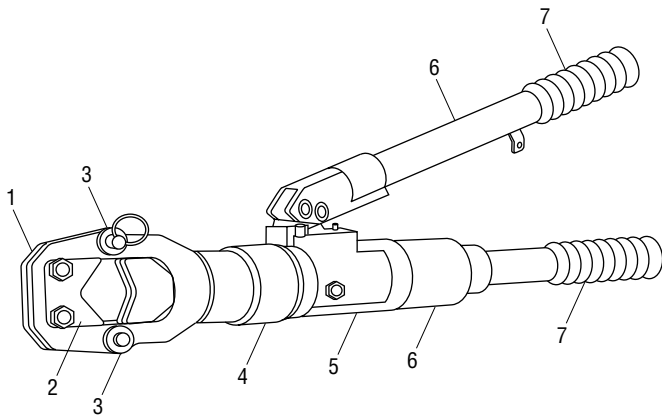

#### Serial Code WH

1. The crimping head is slightly tapered.
2. The fixed die is a bolt-on assembly which includes four bright zinc-plated die plates.
3. The two arms on the cylinder each have two machined slots for the die assembly to engage.
4. Serial number begins with “WH” prefix.
5. The pump block is covered with a black rubber coating.
6. The handles are bonded assemblies and include fiberglass inserts.
7. The handle grips are lobed.

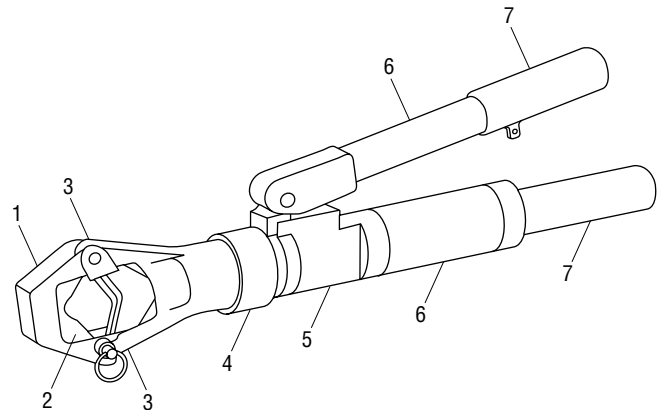

#### Serial Code YM

1. The crimping head is more steeply tapered.
2. The fixed die is one-piece steel casting, colored black.
3. The two arms on the cylinder are not slotted.
4. Serial number begins with “YM” prefix.
5. The pump block is covered with a green rubber coating.
6. The handles are one-piece cast aluminum, covered with green rubber.
7. The handle grips have “motorcycle style” ribs.

*Note: The Greenlee 44999 is similar in appearance to these tools, with some major differences:*

- Serial Code is not WH or YM.
- Movable die is yellow.
- Decal on the handle identifies it as a utility tool.
- “44999” is molded into the rubber covering on the block.

*For repair instructions for this tool, see Service Bulletin SB 243.*

## Tools and Supplies

Before beginning any repair procedure in this manual, read the entire section to be sure all of the necessary tools and supplies are available.

Tools and supplies for most procedures include:

- Bench vise with jaw protectors to secure the tool
- Quality pressure gauge with 1/2% accuracy and a range of 0 to 700 Bar (0 to 10,000 psi)
- Gauge adapter:
  - Serial Code WH: 1/16" NPT male pipe adapter
  - Serial Code YM: 1/8" SAE straight thread adapter (Greenlee 36246)
- 32 mm (1-1/4") diameter aluminum rod, at least 76 mm (3") long
- RTV (room-temperature vulcanizing) silicone rubber adhesive/sealant, such as Dow Corning® Silastic® 732® Multipurpose Sealant
- Pressure Test Kit (Greenlee 32891)
- Exxon Univis® J26 hydraulic oil
- Serial Code WH only: dry white lubricant (silicone or talcum)

Tools and supplies for some specific procedures include:

- C-clamp, arbor press, or other means of retaining the ram spring when disassembling and assembling the cylinder
- Spanner wrench for removing the pressure-adjusting valve body from the pump block

## Pressure Check Procedure

1. Clamp the tool head gently in a vise with the handles upward. Fully retract the ram.

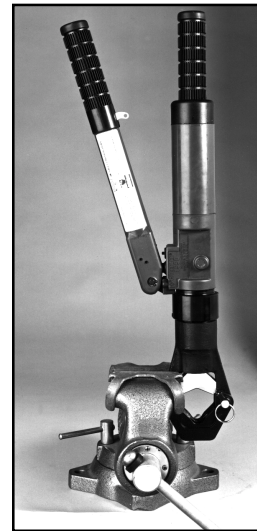

2. Remove the RTV (98) and port plug (97).
3. Install the pressure gauge with the gauge adapter into the port that the plug (97) was removed from.
4. Pump the handle to fully extend the ram. Note the pressure required to open the relief valve (which produces an audible click). The relief pressure should be 90 to 103 Bar (1300 to 1500 psi).
5. Retract the ram and place the 32 mm (1-1/4") diameter aluminum rod between the dies. Pump the handle until the relief valve opens. Note the pressure required to open the relief valve. The relief pressure should be 566 to 675 Bar (8200 to 9800 psi).
6. If the crimping tool's relief pressure is:
  - **within** the ranges stated in Step 4 or Step 5, remove the gauge and adapter, replace the plug (97) and reseal with RTV (98). Add hydraulic oil (see Air Purging and Oil Filling Procedure).
  - **not within** the ranges stated in Step 4 or Step 5, proceed to the Pressure Adjustment Procedure.

## Pressure Adjustment Procedure

1. Fully retract the ram, then pump the handle one stroke.
2. Remove the RTV (16) and set screw (17) from the fixed handle assembly (18).

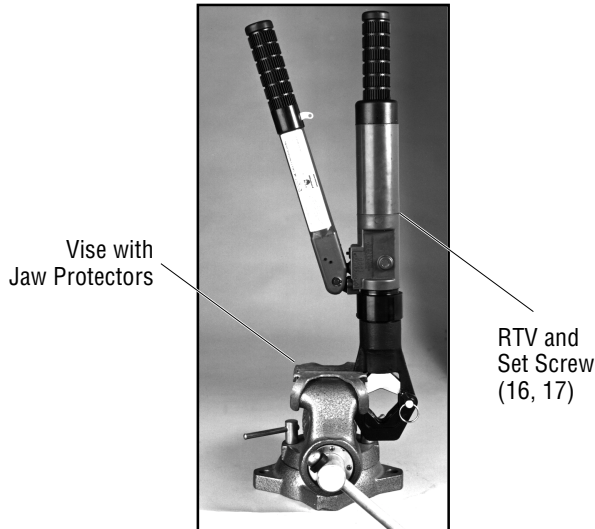

3. Unscrew the fixed handle assembly (18) from the tool body.
4. Pump the handle to fully extend the ram.
5. Remove the plug (19) from the reservoir, taking care not to spill the oil.

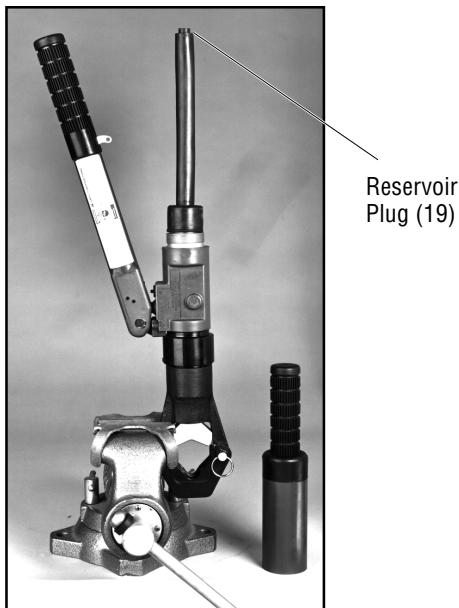

6. Remove the tool from the vise and pour the oil into a waste oil container.
7. Clamp to tool head in the vise. Remove O-ring (21) and reservoir (20). Add oil until the pump block is 3/4 full.

8. Serial Code WH: Remove RTV (101) and screw (100).
9. Loosen fastener (92).
10. Adjust the pressure by turning screw (93) in small increments. Each 15° of adjustment makes a difference of approximately 10 Bar (150 psi). Adjust as follows:
  - **clockwise to increase** relief pressure
  - **counterclockwise to decrease** relief pressure
11. Install reservoir (20).
12. Pump the handle to fully extend the ram. Note the pressure required to open the relief valve (which produces an audible click). Repeat the adjustment procedure until the valve consistently relieves between 90 and 103 Bar (1300 to 1500 psi).
13. Serial Code WH: Tighten the set screw (92). Install the nylon washer (99) and screw (100).  
Serial Code YM: Tighten the jam nut (92).
14. Pump to achieve pressure relief, to ensure that the adjustment was not disturbed during Step 13.
15. Install the reservoir (20) and O-ring (21).
16. Retract the ram fully.
17. Repeat Step 5 of the Pressure Check Procedure.
18. Remove the gauge and adapter and install the port plug (97).
19. Add hydraulic oil to the reservoir until it overflows.
20. Cover the reservoir with a **clean** shop cloth. Pump the handle 10 to 12 times, then retract the ram fully. Repeat several times to eliminate any air in the system.
21. With the pump handle vertical and the ram fully retracted, fill the reservoir until it overflows.  
*Note: The pump handle must be all the way up and the ram must be fully retracted. Otherwise, you may overfill the reservoir which will cause it to leak.*
22. Install the reservoir plug (19) and wipe off all excess oil.
23. Serial Code WH: Coat the reservoir lightly with a dry white lubricant (silicone or talcum).
24. Pump the handle one stroke and install the reservoir handle (18). Install the set screw (17) and tighten securely.
25. Clean the following items, then cover them with an RTV sealant:
  - set screw (17)
  - pipe plug (97)
  - screw (100)

## Pressure Calibration Check

To perform this procedure, use Pressure Test Kit 32891.

1. Rotate the swivel head fully counterclockwise.
2. Clamp the tool head gently in a vise with the handles upward.
3. Remove the RTV (98) and port plug (97).
4. Install the pressure gauge with the gauge adapter into the port that the plug (97) was removed from.
5. Center a new test slug in the dies and pump the handle. Note the pressure required to open the relief valve (which produces an audible click).
6. Repeat Step 5 twice, for a total of three slugs. The relief pressure for every slug should be 214 to 289 Bar (3100 to 4200 psi).
7. Evaluate every test slug with the Go/No Go gauge as shown.
  - If the test slug checkpoint does not fit into GO slot, the pressure relief valve is set too low.
  - If the test slug checkpoint fits into the NO GO slot, the pressure relief valve is set too high.
  - If the test slug checkpoint fits into the GO slot and does not fit into the NO GO slot, the pressure relief valve is set correctly.

Check Point (center depression of the three depression side)

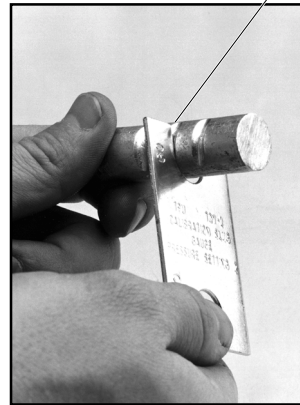

**“Go” Gauge**



**“No Go” Gauge**



## Air Purging and Oil Filling Procedure

Fill the reservoir with Exxon Univis® J26 all temperature hydraulic oil only.

### IMPORTANT

Do not fill the hydraulic reservoir with any other type of fluid (such as brake fluid, glycerin, castor oil, etc.).

Filling the reservoir with anything other than hydraulic fluid will damage the tool and void the warranty.

1. Clamp the tool into a vise with jaw protectors so the handles are upward, as shown.

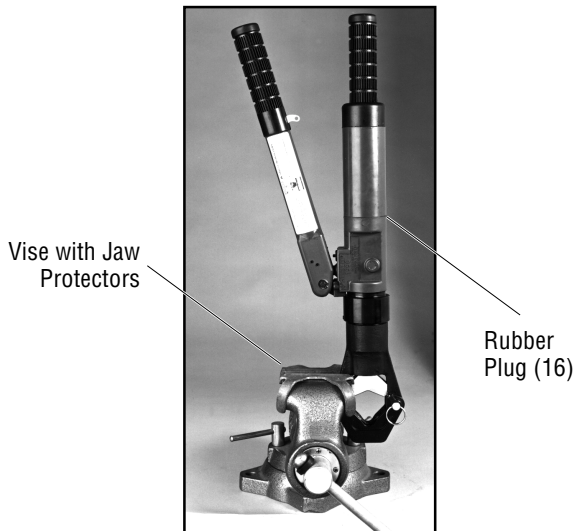

2. Retract the ram by pulling the release trigger back while pressing down on the handle.
3. Pump the handle one partial stroke.
4. Peel out the rubber plug (16) and remove the set screw (17) from the reservoir handle (18).

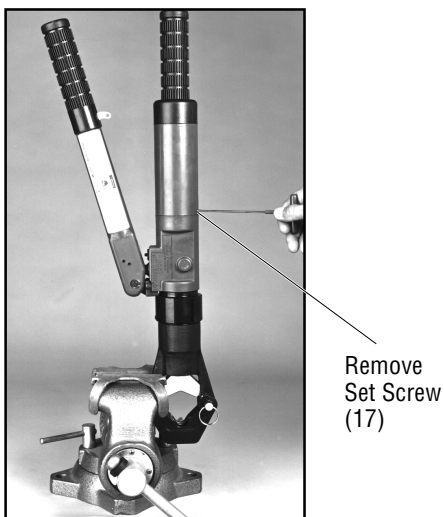

5. Unscrew the reservoir handle from the crimper. Remove the plug (19) from the reservoir.

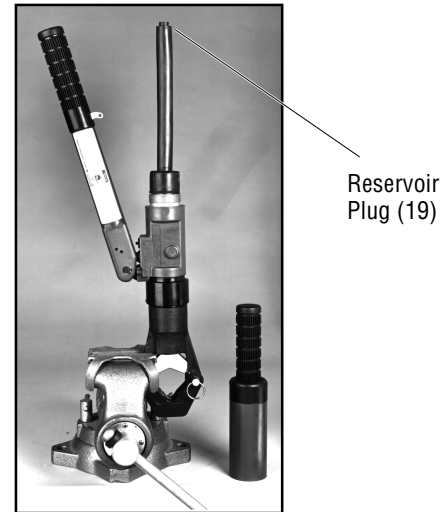

6. Retract the ram fully.
7. Add oil until the reservoir overflows.



8. Pump the handle several times to advance the ram. While holding a **clean** shop cloth over the reservoir, retract the ram fully. Repeat several times to purge all of the air from the system.
9. With the pump handle vertical and the ram fully retracted, fill the reservoir until it overflows.
10. Replace the plug (19) and wipe off excess oil.  
Serial Code WH: Coat the reservoir with a dry white lubricant (silicone or talcum).
11. Pump the handle one stroke and install the reservoir handle (18). Replace the set screw (17) and tighten securely.
12. Cover the set screw with a silicone rubber sealant, such as Dow Corning® Silastic® 732® Multipurpose Sealant.



## Die Replacement

This procedure is divided into two sections — one for the fixed die (which has some steps that are particular to the serial code) and one for the movable die (which includes both serial codes).

### Fixed Die

1. Pull the pin (23). Remove one retaining ring (27), pin (24) and fixed die assembly.
2. Serial Code WH: Note the positions and alignment of the two outer die plates and two inner die plates. Remove the jam nuts (29) and bolts (28). Remove the die plates (30, 31).

Install new die plates, ensuring that they are located properly in the appropriate grooves, and that they are in the proper sequence.

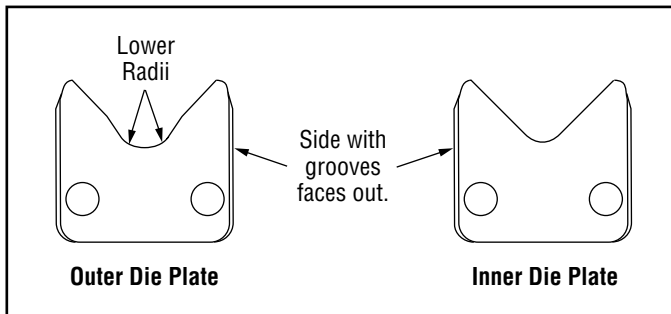

3. Serial Code YM: Transfer the ball detent (22) and removable pin unit (23) to the new die head. Secure with pin (24) and retaining ring (27).
4. Rotate the cylinder fully counterclockwise and fully retract the ram. Measure the distance between the outermost blades of the movable and fixed dies. The distance should be between 56 and 57.1 mm (2.205" and 2.250"). If the dimension is outside of this range, remove the set screw (25) and movable die (26) and change the number of spacers as follows:

- to increase the distance, remove a spacer (102)
- to decrease the distance, add a spacer (102)

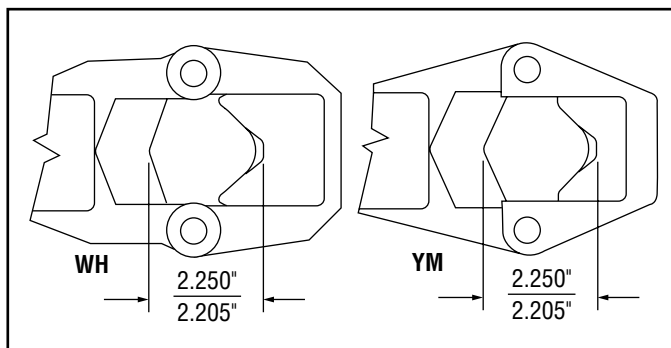

5. Install the movable die (26) and secure with the set screw (25).

### Movable Die — Either Serial Code

1. Remove the fixed die. See Step 1 under Fixed Die.
2. Remove set screw (25) and movable die (26).
3. Install new movable die and set screw.
4. Install fixed die.
5. Rotate the cylinder fully counterclockwise and fully retract the ram. Measure the distance between the outermost blades of the two dies. The distance should be between 56 and 57.1 mm (2.205" and 2.250"). If the dimension is outside of this range, remove the set screw (25) and movable die (26):
  - to increase the distance, remove a spacer (102)
  - to decrease the distance, add a spacer (102)

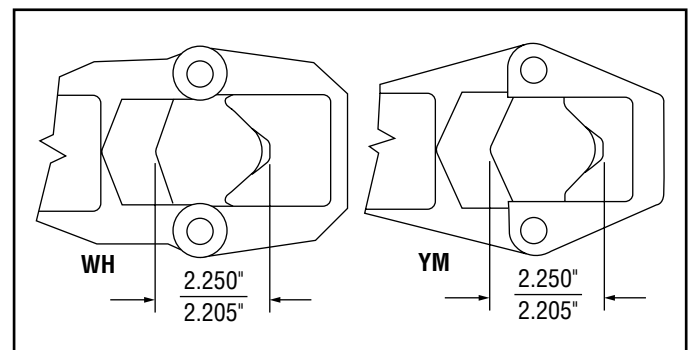

6. Install the movable die (26) and secure with the set screw (25).

## Disassembly

Before performing any repair procedure:

1. Refer to the Service Tips and Troubleshooting sections to determine the appropriate service procedure.
2. Read through the entire procedure to be sure that you have all of the necessary tools, repair parts and supplies.

When performing any service procedure:

1. Check all disassembled parts for wear or damage.
2. Visually inspect the ball seats.
3. Carefully replace any O-rings, backup rings, and other disposable items.
4. Check all items for dirt, grit or other contaminants.

The disassembly procedure is divided into five basic sections, in this order:

1. Cylinder
2. Cylinder Cap
3. Reservoir
4. Pump Block, Relief Valves, and Pressure Release Mechanism
5. Pump Pistons

### Cylinder

#### ⚠ CAUTION

The spring stores at least 310 Newtons (70 pounds) of force. Follow this procedure exactly as instructed to release the pressure on the spring carefully.

Failure to observe this precaution will release all of the energy in the spring at once, resulting in injury due to flying parts.

1. Clamp the pump block in a vise with the handles downward. Fully retract the ram.
2. Loosen the set screw (96) and unscrew the cylinder (33) from the cylinder cap (42).

*Note: Pull the cylinder straight off of the cap to prevent damaging the driving rod.*

3. Pull the cylinder away from the cylinder cap 40 mm (1-1/2") and remove the rod retaining screw (95). Remove the driving rod (94).

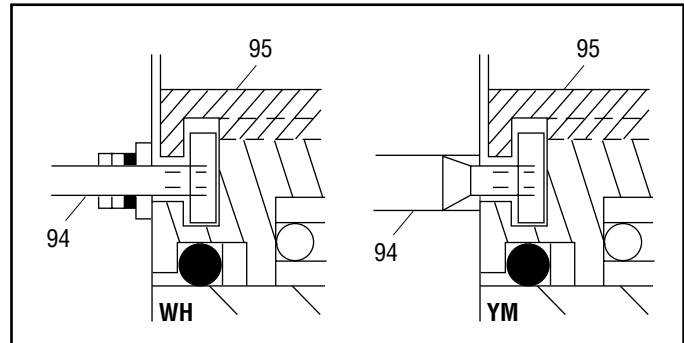

4. If the cylinder does not require service, proceed to Cylinder Cap.
5. Clamp the cylinder assembly in a vise and support the back of the ram with a C-clamp or arbor press, if available.

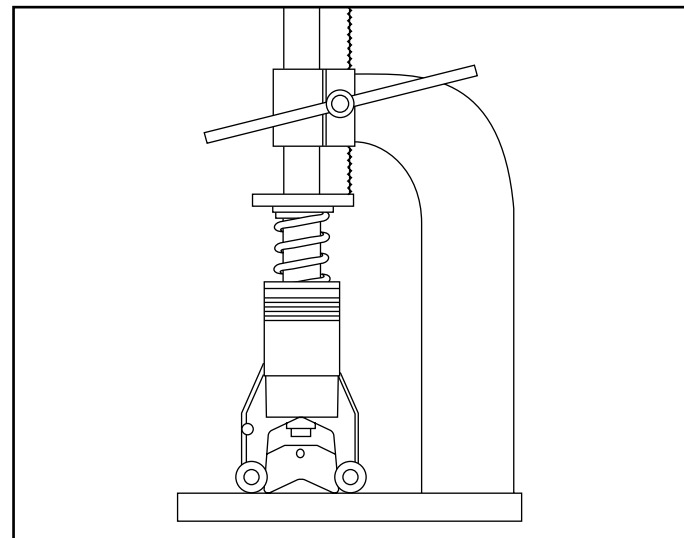

6. Loosen the set screw (25) that secures the movable die (26). Allow the ram to move far enough to release the tension in the spring.
7. Disassemble the C-clamp or arbor press setup.
8. Remove the set screw (25), movable die (26), ram (38), spring (39), guide (35) and wiper (34).
9. Replace all available packing (O-rings, backup rings, springs, balls, wiper, etc.).

## Disassembly (cont'd)

### Cylinder Cap — Serial Code WH

1. Unscrew the driving rod (94) from the stepped rod (84).
2. Remove four cap screws and copper washers (59, 60). Remove the cylinder cap (42).
3. Inspect various components (43–45, 54, 55). Replace if worn or damaged.
4. Remove the check ball bushing (58), ball (53) and spring (57). Inspect the O-ring (56).

### Cylinder Cap — Serial Code YM

1. Unscrew the driving rod (94) from the stepped rod (84).  
*Note: To service the check valves (49, 58) only, proceed to Step 4.*
2. Remove four cap screws and copper washers (59, 60). Remove the cylinder cap (42).  
*Note: The cylinder cap must come straight off.*
3. Inspect various components (43, 44, 54, 55). Replace if worn or damaged.
4. Remove the check ball sleeve (58), ball (53), spring (57), O-rings (29, 56) and backup ring (32).

### Reservoir

1. Reposition the tool in the vise so that the handles are upward. Retract the ram by pulling the release trigger back while pressing down the handle.
2. Peel out the RTV (16) and remove the set screw (17) from the reservoir handle (18).
3. Unscrew the reservoir handle from the pump block (46).
4. Remove the plug (19) from the reservoir (20).
5. Remove the tool from the vise and pour the oil into a waste oil container.
6. Remove O-ring (21) and reservoir (20) from the pump block.

### Pump Block, Relief Valves, and Pressure Release Mechanism

1. Serial Code WH: Remove RTV (101), screw (100) and nylon washer (99). Turn set screw (93) clockwise until it is flush with the relief valve cap (87).
2. Remove the two machine screws (91) and relief valve cover (90).
3. Slide out the relief valve cap (87) and remove the following parts: stepped rod (84), roller guide (83), adjusting roller (88), two slides (89), valve spring cap (86), valve spring (85) and relief valve plunger (81).

4. Use a spanner wrench to remove the pressure-adjusting valve body (80) and copper washer (82).
5. Disassemble the low pressure relief.

Serial Code WH: Remove the jam screw, spring, and ball (79, 78, 77).

Serial Code YM: Remove RTV, plug, spring, and ball (101, 79, 78, 77).

6. Remove one retaining ring (15) and pin (14) from handle (5). Remove handle assembly.
7. Unscrew the pressure release body (72). Remove the ball (74) and spring (73). Remove the shaft (70) from the body (72). Inspect the O-rings (69, 71) and replace if worn or damaged.  
Serial Code YM: Also remove copper washer (30).
8. Use a T-handle Allen wrench or similar tool to push the check ball insert (49) out.
  - Remove ball and spring (47, 48) from the pump block (46).
  - Serial Code WH: Remove roll pin and ball (52, 51) from the insert (49).
  - Serial Code YM: Remove roll pin and ball (52, 51) from the body (49).
  - Inspect the O-ring (50).

### Pump Piston

1. Remove one retaining ring (15) and pin (14) from handle (5). Remove handle assembly.
2. Remove cap screws (13) and pivot block (12).
3. Pull the low pressure plunger (66) upward and out of the pump block. Check O-rings, quad ring (Serial Code YM only) and backup rings (62–65), and replace if worn or damaged.
4. Use an Allen wrench to unscrew the high-pressure plunger (68).
5. Remove the copper washer (67).
6. Use a T-handle Allen wrench or similar tool to push the check ball insert (49) out.
  - Remove ball and spring (47, 48) from the pump block (46).
  - Remove roll pin and ball (52, 51) from the insert (49).
  - Inspect the O-rings (31, 50).

## Assembly

*Note: Lubricate all O-rings and backup rings before assembling.*

### Cylinder

#### CAUTION

The spring stores at least 310 Newtons (70 pounds) of force. Follow this procedure exactly as instructed to contain the spring and its energy.

Failure to contain the spring will release all of its energy, resulting in injury due to flying parts.

1. Install backup ring (37) and O-ring (36) onto ram (38).
2. Clamp the cylinder (33) in a vise with the bore upward. Install wiper and guide (34, 35).
3. Install spring (39) and ram assembly into cylinder (33). Compress the spring using either an arbor press or a C-clamp.

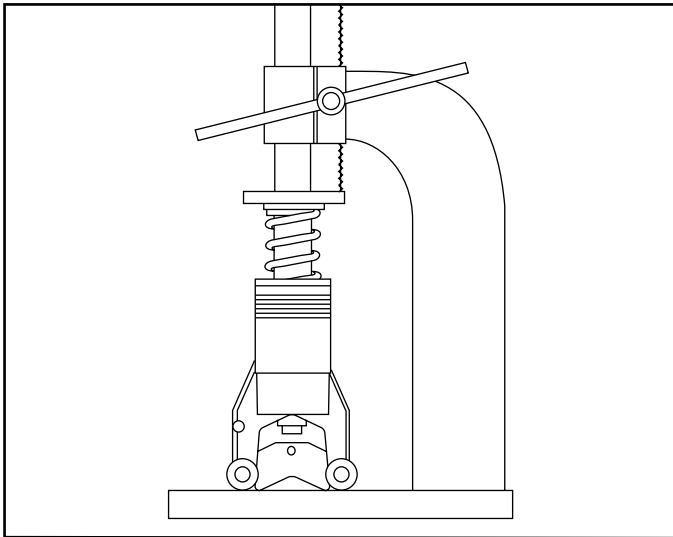

4. Slide the ram die (26) into place. Tighten set screw (25) securely.
5. Set the assembly aside.

### Cylinder Cap Assembly

1. Install the seal and backup washer (40, 41) into the cylinder cap (42).  
Serial Code WH: Install backup ring (43), O-ring (44) and retaining ring (45) onto the cylinder cap.
2. Set the assembly aside.

### Pump Block Assembly — Serial Code WH

Perform this procedure with the pump block (46) secured in the vise with the threaded end downward.

1. Assemble the check ball insert assembly (49) as follows: Install O-ring (50), 3/16" diameter ball (51), and roll pin (52). Set this assembly aside.  
*Note: Roll pin must be below the surface of the check ball insert. A protruding roll pin will damage the pump block.*
2. Assemble 3/16" diameter ball (47) and spring (48) — with small end toward ball — into the pump block (46). Install check ball insert assembly (49) into pump block. Insert 1/4" diameter ball (53) into the check ball insert assembly. Seat each ball in its hole.
3. Loosen jam screw (61). Assemble O-rings (54–56), bushing (58) and spring (57) to cylinder cap. Torque the bushing (58) to 4 Newton-meters (3 foot-pounds).
4. Set cylinder cap in place on the pump block and install four copper washers (56) and cap screws (59). Torque to 27 Newton-meters (20 foot-pounds).
5. Twist jam screw (61) clockwise until set.

### Pump Block Assembly — Serial Code YM

Perform this procedure with the pump block (46) secured in the vise with the threaded end downward.

1. Assemble the check ball insert assembly (49) as follows: Install O-rings (50, 31), install and seat 3/16" diameter ball (51), and install roll pin (52). Set this assembly aside.
2. Assemble 3/16" diameter ball (47) and spring (48) — with small end toward ball — into the pump block (46). Install check ball insert assembly (49) into pump block. Insert 1/4" diameter ball (53) into the check ball insert assembly. Seat each ball in its hole.
3. Assemble the sleeve (58) with O-rings (29, 56), backup ring (32) and spring (57) to the pump block. Torque the sleeve (58) to 4 Newton-meters (3 foot-pounds).
4. Assemble the O-ring (44), backup ring (43) and copper washers (54, 55) to the cylinder cap (42).
5. Set cylinder cap in place on the pump block and install four copper washers (56) and cap screws (59). Torque to 27 Newton-meters (20 foot-pounds).

### Pump Plunger Assembly

1. Cut 6 mm (1/4") off of backup ring (62) to prevent overlap. Assemble O-rings and backup rings (63, 62, 65, 64) to the low-pressure plunger (66).
2. Assemble copper washer (67) and high-pressure plunger (68) to the pump block. Torque to 24.5 to 27 Newton-meters (18 to 20 foot-pounds).
3. Install low-pressure plunger assembly onto the high-pressure plunger assembly.

## Assembly (cont'd)

### Pressure Release Assembly

1. Assemble O-ring (69) to pressure release shaft (70). Assemble O-ring (71) to pressure release body (72).
2. Slide shaft assembly into body assembly.  
Serial Code YM: Set washer (30) into recess in pump block.
3. Install spring (73) and 9/32" ball (74) into the pump block.
4. Assemble pressure release assembly to pump block. Torque to 8 to 9.25 Newton-meters (6 to 7 foot-pounds).

### Relief Valve/Pressure Control Assembly

1. Assemble low-pressure relief components:  
Serial Code WH: Clamp the pump block in the vise with the threaded end upward. Install ball (77), spring (78) and jam screw (79). Turn jam screw clockwise until it is flush with the surface.  
Serial Code YM: Install ball (77), spring (78) and plug (79) to the side of the pump block.
2. Set the pressure-adjusting valve body (80) on a hard surface. Insert the valve plunger (81) into the body. Using a punch and hammer, tap the plunger **with a moderate amount of force** to seat it in the body.  
*Note: Using excessive force will damage the body.*
3. Install the copper washer (82) and relief valve body (80) to the pump block. Torque to 27.25 to 32.5 Newton-meters (20 to 24 foot-pounds).
4. Insert the roller guide (83) into the pump block. Slide the stepped rod (84) into the roller guide.

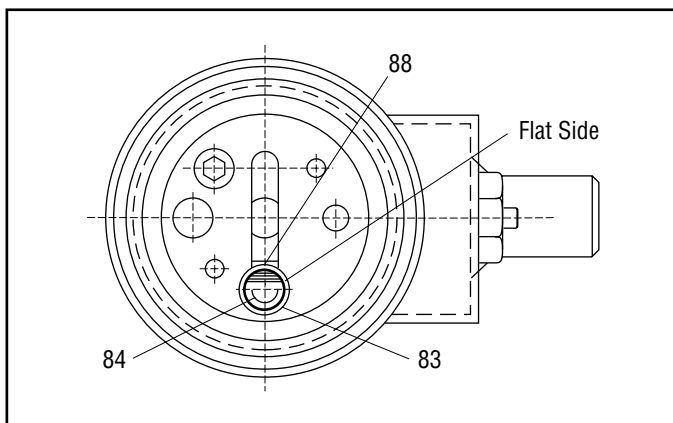

5. Tilt the tool so that the roller guide is at the bottom side. Insert the valve spring (85) and spring cap (86).
6. Install relief valve cap (87).  
Serial Code WH: Screw the set screw (93) into valve cap until three or four threads are showing above the surface. Secure it with the jam screw (92).
7. Install the roller (88) in the notch of the roller guide (83).
8. Insert the two slides (89) into the slot against the roller and spring cap. See the illustration for proper orientation. Use care so that the roller remains in its slot.

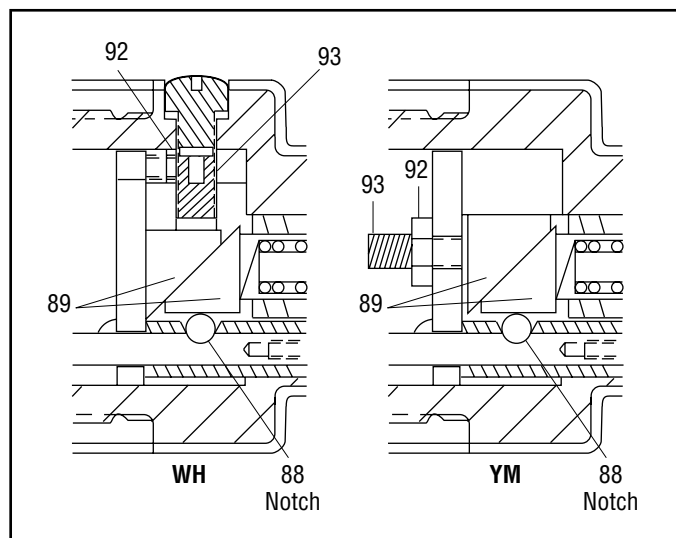

9. Install the relief valve cover (90) and adjust it so that the stepped rod moves freely. Secure the cover with two machine screws (91).

Serial Code YM: Install set screw (93) and secure it with jam nut (92).

**Assembly (cont'd)**

**Assembly of Cylinder to Cylinder Cap**

1. Push the stepped rod (84) out until the adjustment roller (88) drops into the notch in the guide roller (88), which will produce an audible “click”.
2. Apply a threadlocking compound, such as Loctite® 222 Threadlocker or equivalent, to the threads of the driving rod (94). Screw the driving rod into the roller guide (83) until the driving rod just bottoms on the cylinder cap. **This setting is critical to the proper operation of the tool.**

*Hint: For ease of assembly, screw the driving rod clockwise until the flats are aligned as shown.*

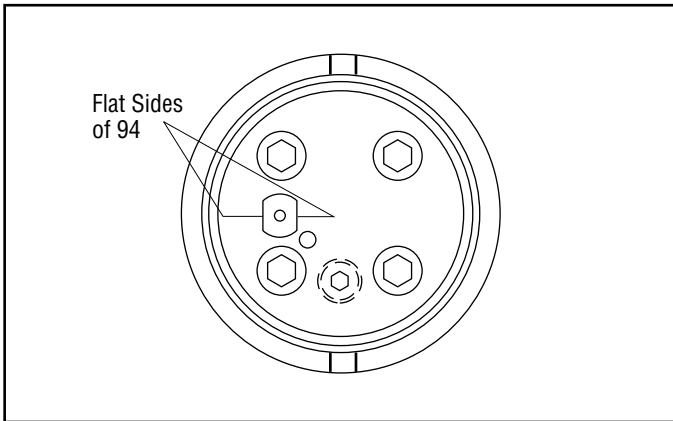

3. Pull the driving rod out 38 mm (1-1/2").  
*Note: Pulling the rod out too far will cause the roller (88) to fall off of the stepped rod. If this happens, disassemble and start over at Step 1.*
4. Hook the head of the driving rod (94) into the groove of the ram (38).
5. Apply a threadlocking compound, such as Loctite® 222 Threadlocker or equivalent, to the threads of the rod retaining screw (95). Screw the retaining rod in until it is 0.81 mm (.032") below the back surface of the ram.

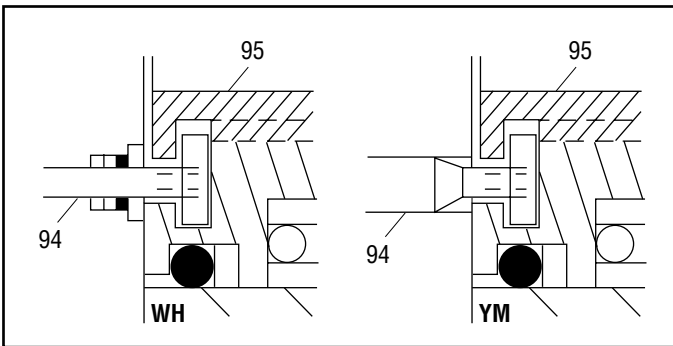

6. Screw the cylinder assembly (33) into the cylinder cap until it is fully bottomed. Back the cylinder out to allow installation of the set screw (96), as follows:
  - Do not back the cylinder out more than 180°.
  - There are two tapped holes for the set screw. Install the set screw in either hole.
  - Adjust the set screw (in or out) until the head rotates 180° freely.
  - Do not tighten the set screw.

**Pump Handle Assembly**

1. Assemble release trigger (2) to pressure release rod (3) with roll pin (4). Insert into handle (5) and fasten with roll pin (7).  
Serial Code WH: Install trigger stop roll pin (6).
2. Assemble the pressure release bar (8) and torsion spring (9) to the handle with roll pins (10). Glue grip (11) to handle (5).
3. Mount the lever pivot block (12) to the pump block. Fasten with two cap screws (13). Torque to 20 Newton-meters (15 foot-pounds).
4. Install the pump handle as follows:  
Serial Code WH: Secure the handle to the lever pivot block (12) and low pressure plunger (66) with two pins (14). Secure the pins with retaining rings (15).  
Serial Code YM: One pin is permanently mounted in the handle. Install the handle so this pin engages the low-pressure plunger (66). Then fasten the handle to the lever pivot block (12) with the pin (14). Secure the pin with retaining rings (15).
5. Serial Code WH: Assemble the fixed die head. See the following illustration and the exploded view.

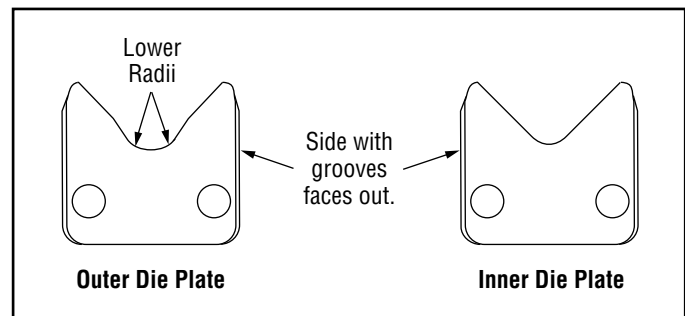

- Install the bolts (28) and nuts (29). Torque to 13.5 Newton-meters (10 foot-pounds).
6. Serial Code YM: Assemble the detent (22) to the die head (28).
  7. Install the spacer(s) (102) and movable die (26). Secure by tightening set screw (25).
  8. Fasten the fixed die to cylinder with pins (23, 24). Secure pin (24) with retaining rings (27).

## Assembly (cont'd)

### Final Assembly

1. Rotate the cylinder counterclockwise until it stops. Fully retract the ram.
2. Measure the distance between the outermost blades of the movable and fixed dies. The distance should be between 56 and 57.1 mm (2.205" and 2.250"). If the dimension is outside of this range, remove the set screw (25) and movable die (26) and change the number of spacers as follows:
  - to increase the distance, remove a spacer (102)
  - to decrease the distance, add a spacer (102)

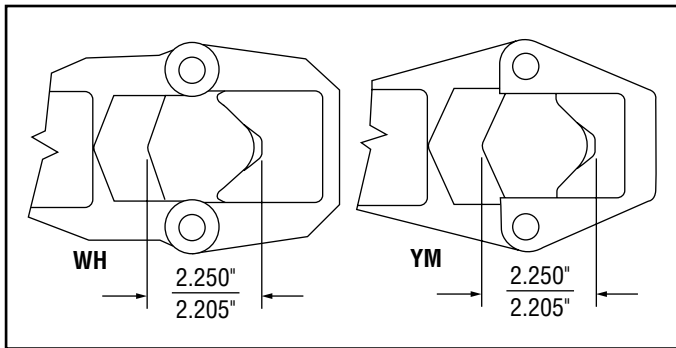

3. Install the movable die (26) and secure with the set screw (25).
4. With the tool still in the vise, pour some hydraulic oil into the pump block. Pump the handle until the ram is fully extended.  
*Note: When the ram is fully extended, the handle resistance will increase and some oil will squirt back.*
5. Install reservoir (20) and O-ring (21). Retract the ram and purge air from the tool. Add oil until reservoir overflows. Wipe off the excess oil.
6. Proceed to calibrate the tool. See the Pressure Adjustment Procedure.

## Service Tips

- If the hydraulic system has air in it, purge the air and top off the oil as instructed under Air Purging and Oil Filling procedure. See **Air in the Hydraulic System** at the end of the troubleshooting table.
- Check valve service requires removal of the cylinder and cylinder cap. Inspect the ball seats in the pump block and check body.
- If performing release mechanism service, check for clearance between the ball (74) and release pin (70). Inspect the body seat, body seats at the bottom of the hole, and (Serial Code WH) against the block or (Serial Code YM) against the copper washer (30).
- Low pressure relief service:  
Serial Code WH: Drain and remove reservoir (20). Remove relief cap (87) to allow access to the spring retaining screw. Remove screw (79), spring (78) and ball (77). Inspect parts for contaminants and seat for damage. Clean and repair.  
Serial Code YM: Remove RTV (101), O-ring plug (79), spring (78) and ball (77).
- High pressure relief service: Drain and remove reservoir (20). Remove relief cap (87) to allow access to the relief valve and control mechanism. Remove slides (89), roller (88), spring cap (86) and spring (85). Remove cone (81). Check torque on the adjusting body. Reseat cone, clean and assemble.
- Pump piston O-rings: Remove retaining rings (15) from pins (14) and remove handle unit from pump block (46). Remove the two cap screws (13) and pivot block (12). Pull the low pressure plunger (66) upward and out of the pump block. Check O-rings and backup rings (62–65), and replace if worn or damaged.
- The pump handle can be disassembled by removing the front pin and pivoting the handle up and beyond the normal stroke.



## Retrofit Kits

Many components are interchangeable between the older (WH) and current (YM) crimping tools. However, some components are not interchangeable, requiring

the replacement of several components at once. Use this table to select the appropriate repair kit.

Crimping Tool Part	Purchase Repair Kit	Explanation
Relief valve cap (87) or cover (90)	36150	Repair kit includes cap, cover, nut and screw (87, 90, 92, 93).
Crimping head components or cylinder (33)	36149	<p>Failure of either pin will overstress the other components, requiring complete replacement of the crimping head.</p> <p>Repair kit includes pins, YM-type fixed die and cylinder (23, 24, 28, 33). This kit is compatible with WH-style tools also.</p> <p>The pins, dies and cylinder are <b>not</b> individually interchangeable between the WH and YM series.</p> <p>Whenever the cylinder is serviced, replacement of the following is recommended: wiper, guide, O-ring and backup ring (34, 35, 36, 37).</p>
Cylinder cap (42) or pump block (46)	36153	<p>Requires complete rebuild. Repair kit includes a YM-style pump block and all related components, as follows: (29–32, 40–55, 57, 58, 60, 62, 64, 65, 67, 69, 70, 77, 79, 82, 87, 90, 92–94)</p>
Pump handle assembly (with grip)	36152	<p>Repair kit includes the following: (2–5, 7–11, 14, 15, 103)</p> <p>This kit includes a pressure release rod (3) and pressure release bar (8). When installing this YM-type kit onto a WH-type tool, you must retain the WH-type pressure release rod (3) and pressure release bar (8). They are not interchangeable.</p> <p>The grips are <b>not</b> interchangeable. When replacing either handle assembly, you might consider replacing both of them so that two grips are similar in appearance.</p>
Reservoir handle assembly (with grip)	36151	<p>Repair kit includes grip and handle (1, 18).</p> <p>The grips are <b>not</b> interchangeable. When replacing either handle assembly, you might consider replacing both of them so that two grips are similar in appearance.</p>

## Troubleshooting

This table lists some of the most common problems (first column). The probable trouble areas (second column) contain numbers in brackets { } relating to the

problems listed in the first column. Recommended service procedures are provided (third column).

Problem	Probable Trouble Area	Recommended Service
Ram advance: 1. no advance 2. slow advance 3. partial retract with each stroke 4. erratic advance	A. Air in hydraulic system {1, 2, 3, 4}  B. Check valve/body {1, 2, 3} C. Release mechanism {1, 2}  D. Low pressure relief {1, 2} E. High pressure relief {1, 2} F. Plunger O-rings {4}	A. See <b>Air in the Hydraulic System</b> at the end of this troubleshooting table. B. Reseat balls; tighten lock screw. C. Replace O-rings, check ball/pin clearance and reseat (69–73). D. Reseat ball (77). E. Reseat cone (81). F. Replace O-rings (62–68).
Slow pressure buildup: 1. Handle springs back 2. No handle response	A. Discharge check ball {1} B. Check balls/body {1, 2} C. High pressure relief {1} D. Release mechanism {1, 2}	A. Reseat ball. B. Reseat balls. C. Reseat and reassemble. D. Check clearance and seat body.
Tool does not achieve high pressure	A. Check valves/body B. High pressure relief is not seated C. Pressure control mechanism is improperly assembled	A. Replace O-ring, reseat check balls. B. Reseat relief. C. Check the assembly of roller, slides, stepped rod and adjusting screw (80–86, 88, 89).
Ram does not retract	A. Wedged connector B. Die jammed due to misuse  C. Release mechanism D. Bent driving rod	A. Free and remove connector. B. Free die. Inspect tool and replace any damaged parts. C. Make sure ball is not over-traveling. D. Replace rod (94).
Ram retracts partially	A. Too much hydraulic fluid B. Air in hydraulic system  C. Internal parts bind  D. Dies bind	A. Bleed off excess oil. B. See <b>Air in the Hydraulic System</b> at the end of this troubleshooting table. C. Check stepped rod and driving rod for a bind point (84, 94). D. Replace dies.
Pressure setting: 1. does not change as ram advances 2. does not change when adjusting screw setting is changed 3. does not hold adjustment	A. Pressure adjusting screw is loose {1, 3} B. Improper assembly {1, 2}  C. Stepped rod turned {1}. D. Spring cap missing {1, 2} E. Valve cap not tight {1, 2, 3} F. Driving rod disconnected {1, 3}	A. Adjust pressure and tighten screw (92, 93). B. Check the assembly of stepped rod and roller slides (84, 89). C. Turn to position. Adjust pressure. D. Replace cap (86) and adjust pressure. E. Tighten cap (87) and adjust pressure. F. Assemble. Fasten with threadlocking compound.
Internal leak at: 1. low pressure relief 2. high pressure relief 3. stepped rod seals	A. Ball/cone seat damage {1, 2} B. Dirt or grit in the hydraulic system {1, 2} C. Missing or damaged components D. Damaged O-ring {3}	A. Reseat or replace. B. Drain oil; clean parts. Fill with fresh oil. C. Rebuild tool. D. Replace O-ring and backup ring.
External leak at: 1. base of reservoir handle 2. grip 3. inside reservoir handle 4. around release plunger 5. between pump block and cylinder cap 6. around cylinder near cap 7. movable die	A. Damaged reservoir {1, 2, 3} B. Damaged or missing O-ring at reservoir {1, 2, 3} C. Reservoir plug damaged or missing {1, 2, 3} D. O-ring on plunger damaged or missing {4} E. Loose cylinder cap {5} F. O-rings (WH) or copper washers (YM) damaged {5} G. Damaged cylinder seal in cap {6} H. Damaged O-rings and backup ring on ram {7} I. Damaged ram {7}	A. Replace reservoir (20). B. Replace O-ring (21). C. Replace reservoir plug (19). D. Replace O-ring and backup ring (64, 65). E. Tighten screws (59) to proper torque. F. Replace components (43, 44, 45) or (60). G. Replace O-ring and backup ring (40, 41). H. Replace O-ring and backup ring (36, 37). I. Replace ram. Check cylinder bore for damage.
<b>Air in the Hydraulic System</b>	A. Improper fill and purge procedure B. Loose or missing reservoir plug C. Damaged O-ring on low pressure plunger D. Damaged reservoir E. Damaged or missing O-ring on reservoir F. Reservoir is underfilled	A. Fill reservoir and purge air. B. Replace plug, or install plug properly. C. Replace O-ring and backup ring. D. Replace reservoir. E. Replace O-ring. F. Fill reservoir and purge air.

**Illustration — Serial Code WH**

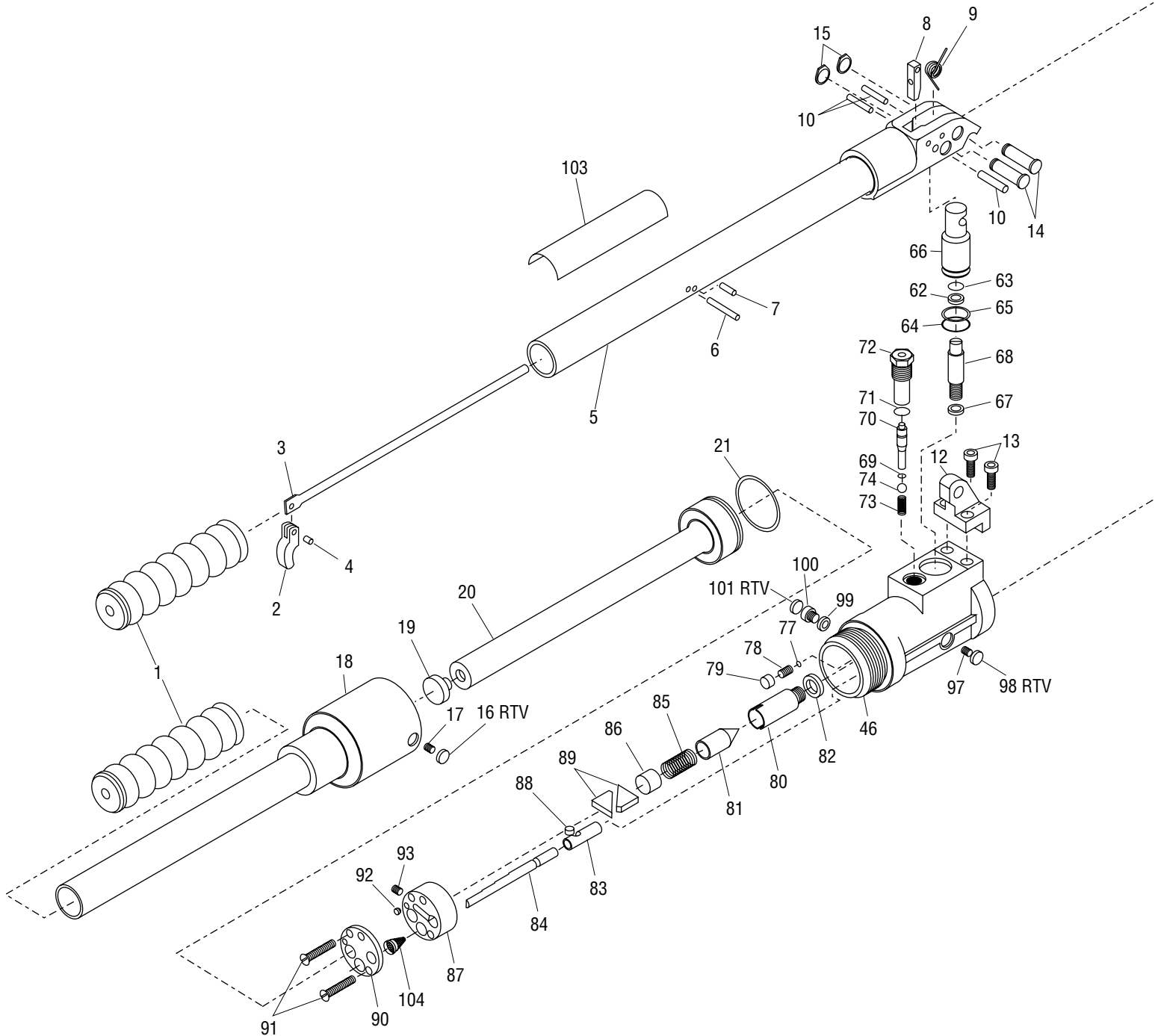

# GREENLEE® 1990 Dieless Hydraulic Crimping Tool

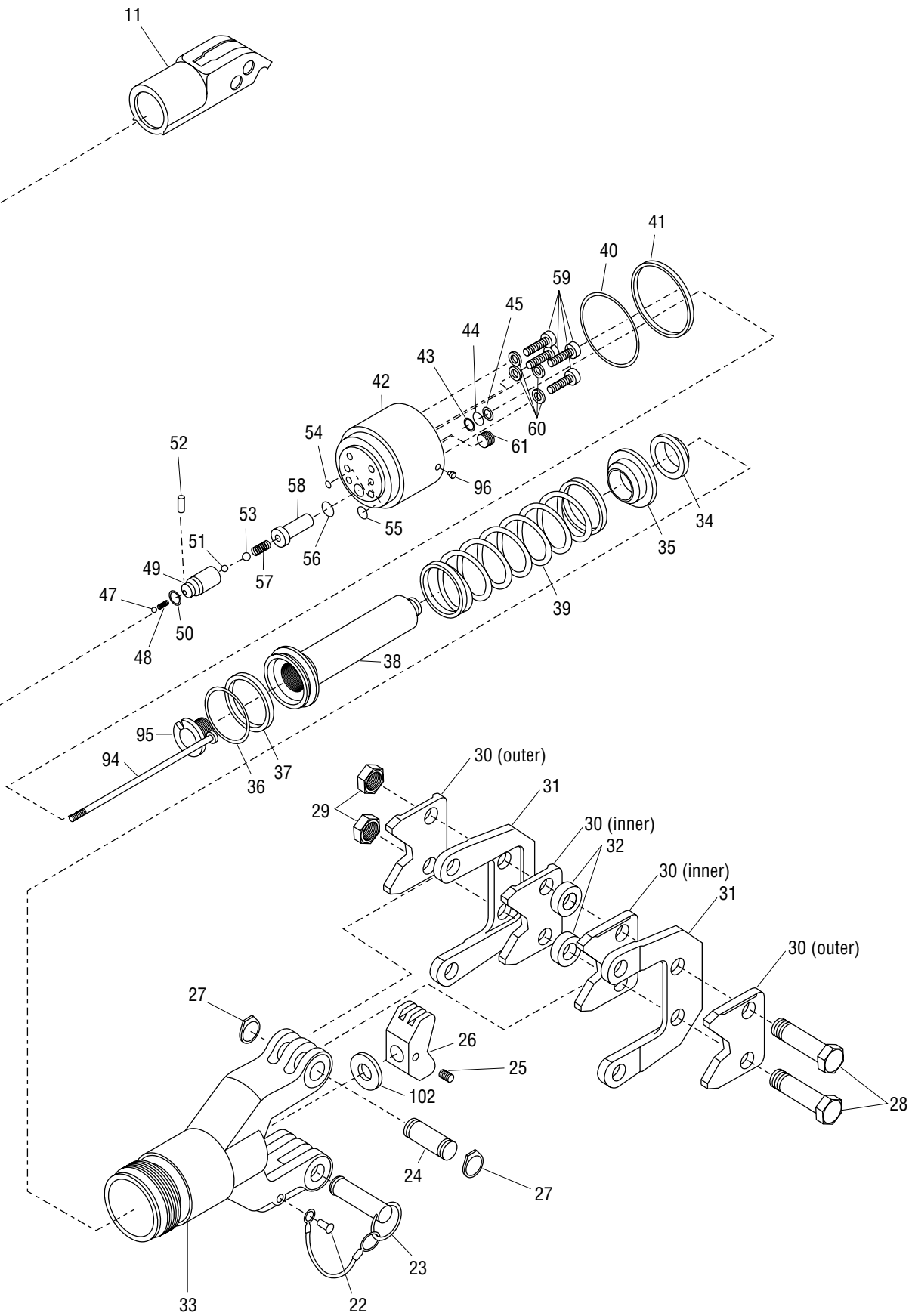

**Parts List — Serial Code WH**

	KEY	UPC NO. 78-3310-	PART NO.	DESCRIPTION	QTY.
▲▶◆	1*	32532	503 2532.9	Grip, Handle.....	2
▲▶	2	03427	500 3427.8	Release Trigger.....	1
▲▶	3	32511	503 2511.6	Rod, Pressure Release.....	1
▲▶	4	50458	905 0458.5	Roll Pin, .125 x .375".....	1
▲▶	5*	32495	503 2495.0	Lever Unit, Handle.....	1
▲▶	6	52482	905 2482.9	Roll Pin, .125 x 1.25".....	1
▲▶	7	50420	905 0420.8	Pin, Release, .125 x 1.00".....	1
▲▶	8	32510	503 2510.8	Bar, Pressure Release.....	1
▲▶✓	9	03334	500 3334.4	Spring, Torsion, .187 x .280 x .312".....	1
▲▶	10	53475	905 3475.1	Pin, Roll, .156 x 1.37".....	3
▲▶	11	32690	503 2690.2	Boot, Pivot Head.....	1
	12	32493	503 2493.4	Pivot, Lever.....	1
	13	51265	905 1265.0	Screw, Cap, 1/4-20 x .750" Socket Head.....	2
▲	14	03418	500 3418.9	Pin, Fulcrum.....	2
▲✓	15	51773	905 1773.3	Ring, Retaining, .312".....	2
	16			RTV	
✓	17	51241	905 1241.3	Screw, Set, #10-32 x .187" Flat Point Socket.....	1
◆	18*	32496	503 2496.9	Handle, Reservoir.....	1
	19	32488	503 2488.8	Plug, Bladder, Rubber, Black.....	1
	20	32530	503 2530.2	Reservoir.....	1
✓	21	53814	905 3814.5	O-ring, 1.47 x 1.71 x .118"-90D.....	1
	22	53599	905 3599.5	Stud, Grooved.....	1
	23	32518	503 2518.3	Pin Unit, Removable.....	1
	24	32517	503 2517.5	Pin, Pivot.....	1
✓	25	52338	905 2338.5	Screw, Set, #10-32 x .250" Socket.....	1
	26	32514	503 2514.0	Die, Movable.....	1
✓	27	51379	905 1379.7	Retaining Ring, .500".....	2
	28	32515	503 2515.9	Bolt, Die Plate.....	2
	29	53478	905 3478.6	Nut, Jam, 7/16-20.....	2
	30*	33015	503 3015.2	Die Replacement Kit (two inner and two outer die plates).....	1
	31*	32499	503 2499.3	Plate, Die Support.....	2
	32*	32516	503 2516.7	Spacer.....	2
	33*	32491	503 2491.8	Cylinder.....	1
✓	34	53464	905 3464.6	Wiper, Ram.....	1
	35	35651	503 5651.8	Guide, Ram.....	1
✓	36	50888	905 0888.2	O-ring, 1.62 x 2.00 x .187" Nitrile.....	1
✓	37	50889	905 0889.0	Backup Ring, Spiral, 1.62 x 1.99 x .033".....	1
	38	32509	503 2509.4	Ram.....	1
	39	32519	503 2519.1	Spring, Compression, 1.49 x 1.82 x 6.06".....	1
▼✓	40	53473	905 3473.5	O-ring, 2.37 x 2.56 x .093".....	1
▼✓	41	53470	905 3470.0	Backup Ring, Single Turn, 2.37 x 2.55 x .050" Teflon.....	1
▼	42	32508	503 2508.6	Cap, Cylinder.....	1
▼✓	43	53480	905 3480.8	Backup Ring, Spiral, .125 x .250 x .049" Teflon.....	1
▼✓	44	50722	905 0722.3	O-ring, .114 x .250 x .068"-70D Nitrile (same as item 69).....	1
▼✓	45	51382	905 1382.7	Retaining Ring, .312".....	1
▼	46*	32691	503 2691.0	Block, Pump.....	1
▼✓	47	50678	905 0678.2	Ball, Steel, .187" Diameter, Grade #25 (same as item 51).....	1
▼✓	48	16141	501 6141.5	Spring, Compression, .194 x .214 x .500".....	1
▼	49	32529	503 2529.9	Check Ball Insert.....	1
▼✓	50	53688	905 3688.6	O-Ring.....	1
▼✓	51	50678	905 0678.2	Ball, Steel, .187" Diameter, Grade #25 (same as item 47).....	1
▼✓	52	51204	905 1204.9	Pin, Roll, .062 x .375".....	1
▼✓	53	50679	905 0679.0	Ball, Steel, .250" Diameter, Grade #25.....	1
▼✓	54	51046	905 1046.1	O-ring, .187 x .312 x .062" Nitrile.....	1
▼✓	55	53469	905 3469.7	O-ring, .156 x .281 x .062".....	1
▼✓	56	51215	905 1215.4	O-ring, .437 x .562 x .062" Nitrile.....	1
▼✓	57	10761	501 0761.5	Spring, Compression, .153 x .203 x .440.....	1
▼	58	32590	503 2590.6	Check Ball Bushing.....	1
	59	50581	905 0581.6	Screw, Cap, 1/4-20 x 1.00" Socket Head.....	4
▼✓	60	32535	503 2535.3	Washer, Flat, .260 x .390 x .046" Copper.....	4
▼✓	61	53474	905 3474.3	Screw, Jam Socket.....	1
▼✓	62	50883	905 0883.1	Backup Ring, Spiral, .375 x .485 x .027" Teflon.....	1
▼✓	63	53689	905 3689.4	O-ring, .334 x .475 x .070".....	1
▼✓	64	50394	905 0394.5	O-ring, .750 x 1.00 x .125"-70D Nitrile.....	1
▼✓	65	51272	905 1272.3	Backup Ring, Spiral, .750 x .992 x .027".....	1

**Parts List — Serial Code WH (cont'd)**

KEY	UPC NO. 78-3310-	PART NO.	DESCRIPTION	QTY.
	66	32503	503 2503.5	Plunger, Lo Pressure ..... 1
▼✓	67	53477	905 3477.8	Washer, Flat, .156 x .250 x .046" Copper ..... 1
	68	32504	503 2504.3	Plunger, Hi Pressure ..... 1
▼✓	69	50722	905 0722.3	O-ring, .114 x .250 x .068"—70D Nitrile (same as item 44) ..... 1
	70	32507	503 2507.8	Shaft, Pressure Release ..... 1
▼✓	71	50168	905 0168.3	O-ring, .364 x .500 x .068"—90D Nitrile ..... 1
	72	32506	503 2506.0	Body, Pressure Release ..... 1
✓	73	32534	503 2534.5	Spring, Compression, .164 x .240 x .750" ..... 1
✓	74	50436	905 0436.4	Ball, Steel, .281 Diameter, Grade #25 ..... 1
▼✓	77	50452	905 0452.6	Ball, Steel, .218 Diameter, Grade #25 ..... 1
✓	78	13263	501 3263.6	Spring, Compression, .184 x .242 x .815" ..... 1
▼✓	79	51337	905 1337.1	Screw, Jam, 5/16—24 x .156 Socket ..... 1
X	80	32523	503 2523.0	Body, Pressure-Adjusting Valve ..... 1
X	81	32789	503 2789.5	Plunger, Valve ..... 1
X▼✓	82	03421	500 3421.9	Washer, Flat, .440 x .687 x .064" Copper ..... 1
	83	32558	503 2558.2	Guide, Roller ..... 1
	84	32562	503 2562.0	Rod, Stepped ..... 1
X✓	85	32572	503 2572.8	Spring, Compression, .178 x .322 x .875" ..... 1
X	86	32561	503 2561.2	Cap, Valve Spring ..... 1
●▼	87*	32556	503 2556.6	Cap, Relief Valve ..... 1
	88	32564	503 2564.7	Roller, Valve Adjustment, .197 x .247" ..... 1
	89	32559	503 2559.0	Slide, Moving ..... 2
●▼	90*	32591	503 2591.4	Cover, Relief Valve ..... 1
✓	91	51462	905 1462.9	Screw, Machine, #10—32 x 1.25" Round Head ..... 2
●▼✓	92	51286	905 1286.3	Screw, Jam, #8—32 x .109 Socket ..... 1
●▼✓	93	53600	905 3600.2	Screw, Set, 1/4—20 x .437 Flat Point Socket ..... 1
▼	94	32563	503 2563.9	Rod Unit, Driving ..... 1
	95	32557	503 2557.4	Screw, Rod Retaining ..... 1
✓	96	51245	905 1245.6	Screw, Set, 1/4-20 x .250" Flat Point Socket ..... 1
▼	97	50824	905 0824.6	Plug, Pipe, 1/16" ..... 1
	98			RTV
✓	99	53482	905 3482.4	Washer, Flat, .259 x .393 x .062" Nylon ..... 1
✓	100	53481	905 3481.6	Screw, Cap, 1/4—20 x .250 Fillister Head ..... 1
	101			RTV
	102	33730	503 3730.0	Spacer, .549 x .997 x .025" Stainless Steel ..... **
▲	103	35462	503 5462.0	Decal, Warning ..... 1
✓	104	22726	502 2726.2	Filter, Oil ..... 1

\*No longer available. See the list of kits at the end of this parts list to retrofit the tool.

\*\*Quantity of one or two, if necessary. To determine if this item is necessary, see Die Replacement procedure.

Decals				
	32792	503 2792.5	Decal, Identification	
	35463	503 5463.9	Decal, Connector Chart	
	35757	503 5757.3	Decal, Instruction	
	35758	503 5758.1	Decal, Pressure Check Procedure	
	35759	503 5759.0	Decal, Safety	
	06233	500 6233.6	Decal, Safety Lid Liner	
	06243	500 6243.3	Decal, Operating Instructions	

Accessory				
	32791	503 2791.7	Case, Carrying	

**Repair Kits, Retrofit Kits, and Supplies**

Replace worn or broken items with newer YM-style components. Some WH-style components are no longer available; corresponding retrofit kits are marked "Required".

	32891	503 2891.3	Slug Test Kit (includes one Go/No Go Gauge and 30 test slugs)
✓	33013	503 3013.6	Hydraulic Repair Kit
X	33737	503 3737.8	Relief Valve Repair Kit (Recommended)
▶	35671	503 5671.2	Pump Handle Unit (Required)
●	36150	503 6150.3	Valve Cap and Cover Repair/Retrofit Kit (Required)
◆	36151	503 6151.1	Reservoir Handle Repair/Retrofit Kit (Required)
▲	36152	503 6152.0	Pump Handle Repair/Retrofit Kit (Required)
▼	36153	503 6153.8	Pump Block Repair/Retrofit Kit (Required)

Replace worn or broken components with identical WH-style components:

✓	33013	503 3013.6	Hydraulic Repair Kit
	33015	503 3015.2	Die Replacement Kit (includes two inner dies and two outer dies)

**Illustration — Serial Code YM**

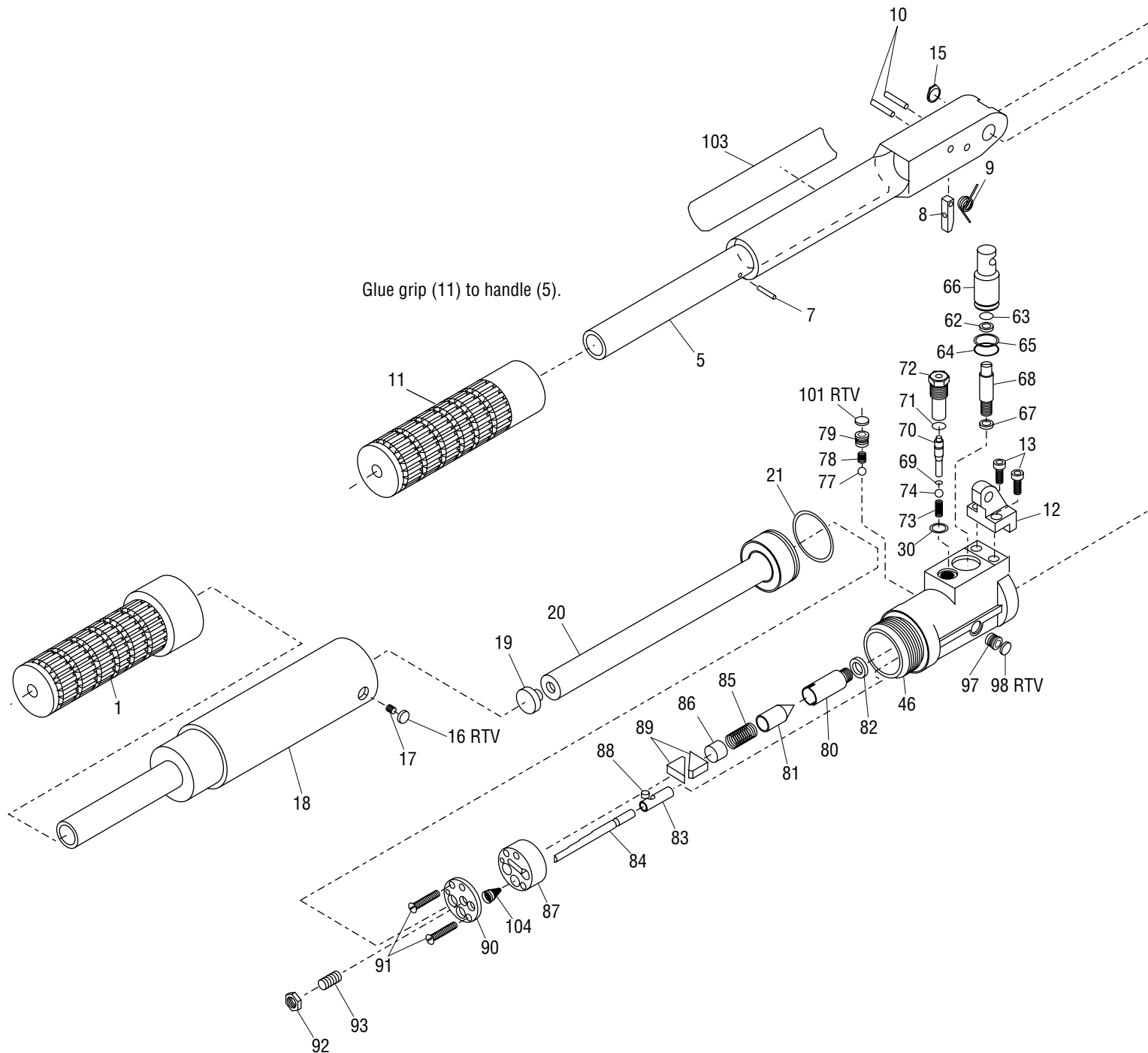



**GREENLEE® 1990 Dieless Hydraulic Crimping Tool**

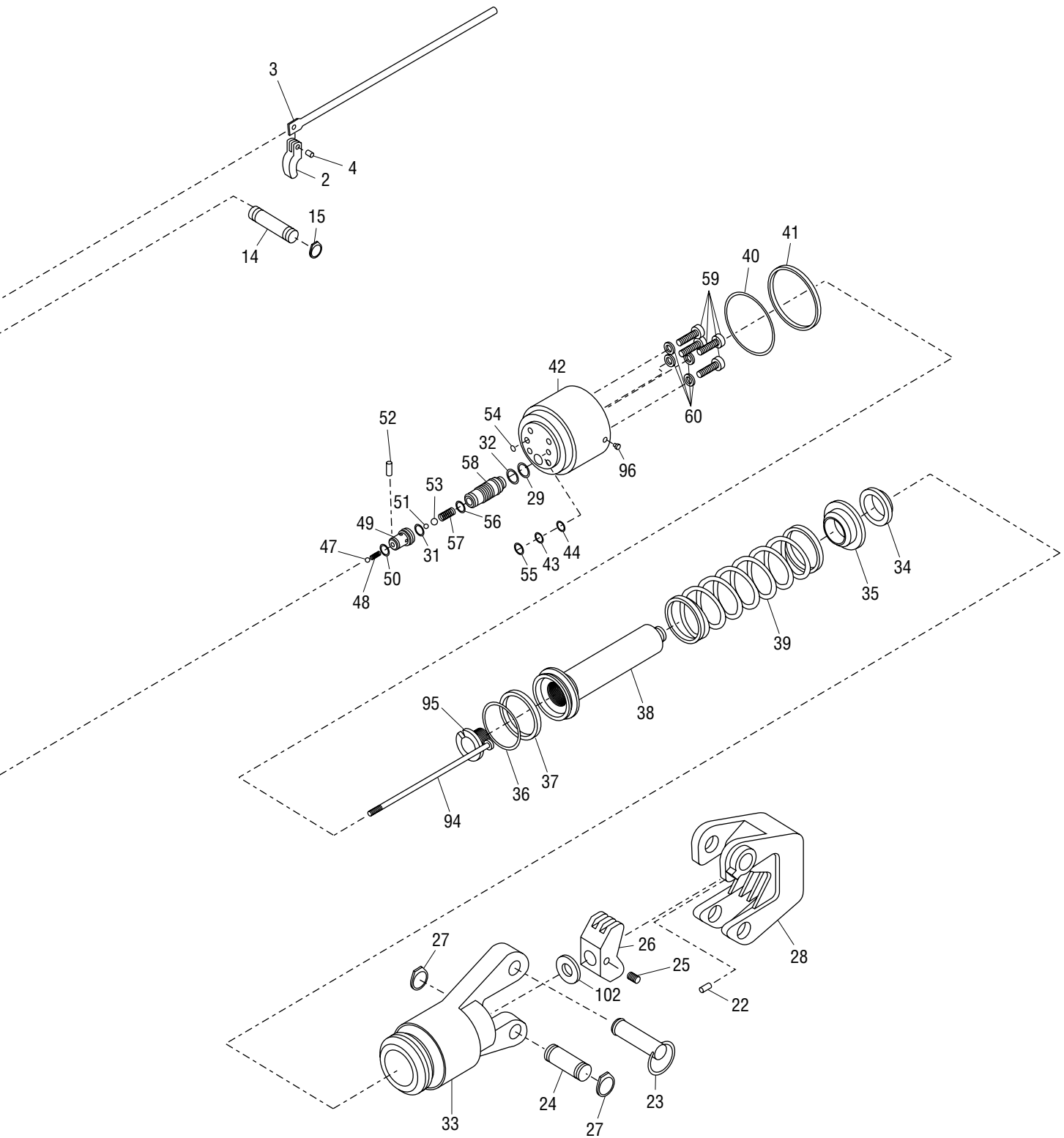

**Parts List — Serial Code YM**

	KEY	UPC NO. 78-3310-	PART NO.	DESCRIPTION	QTY.
◆	1	35689	503 5689.5	Grip, Reservoir Handle .....	1
▲▶	2	03427	500 3427.8	Release Trigger .....	1
▲▶	3	35698	503 5698.4	Rod, Pressure Release.....	1
▲▶	4	50458	905 0458.5	Roll Pin, .125 x .375" .....	1
▲▶	5	35672	503 5672.0	Handle, Pump .....	1
▲▶	7	51048	905 1048.8	Roll Pin, .125 x .625" .....	1
▲▶	8	35697	503 5697.6	Bar, Pressure Release.....	1
▲▶✓	9	03334	500 3334.4	Spring, Torsion, .187 x .280 x .312" .....	1
▲▶	10	53475	905 3475.1	Pin, Roll, .156 x 1.37" .....	2
▲▶	11	35688	503 5688.7	Grip, Rubber, 1.25 x 1.68 x 6.62" .....	1
	12	32493	503 2493.4	Pivot, Lever .....	1
	13	51265	905 1265.0	Screw, Cap, 1/4–20 x .750" Socket Head .....	2
▲	14	35676	503 5676.3	Pin, Fulcrum, .310 x 1.60" .....	1
▲✓	15	52336	905 2336.9	Ring, Retaining, .312" .....	2
	16			RTV	
✓	17	51241	905 1241.3	Screw, Set, #10–32 x .187" Flat Point Socket .....	1
◆	18	35680	503 5680.1	Handle, Reservoir .....	1
	19	32488	503 2488.8	Plug, Bladder, Rubber, Black.....	1
	20	35686	503 5686.0	Bladder, Reservoir .....	1
✓	21	53814	905 3814.5	O-ring, 1.47 x 1.71 x .118"–90D .....	1
■	22	53962	905 3962.1	Detent, Ball .....	1
■	23	35678	503 5678.0	Pin Unit, Removable .....	1
■	24	35673	503 5673.9	Pin, Pivot, .468 x 2.05" .....	1
✓	25	52338	905 2338.5	Screw, Set, #10–32 x .250" Socket .....	1
	26	32514	503 2514.0	Die, Movable .....	1
■✓	27	51379	905 1379.7	Retaining Ring, .500" .....	2
■	28	35677	503 5677.1	Head, Die .....	1
▼✓	29	51215	905 1215.4	O-ring, .437 x .562 x .062" Nitrile .....	1
▼✓	30	35683	503 5683.6	Washer, Flat, .343 x .437 x .046" Copper .....	1
▼✓	31	53689	905 3689.4	O-ring, .334 x .475 x .070" (same as items 56 and 63) .....	1
▼✓	32	52475	905 2475.6	Backup Ring, Spiral, .437 x .562 x .055" .....	1
■	33	35675	503 5675.5	Cylinder.....	1
✓	34	53464	905 3464.6	Wiper, Ram .....	1
	35	35651	503 5651.8	Guide, Ram .....	1
✓	36	50888	905 0888.2	O-ring, 1.62 x 2.00 x .187" Nitrile .....	1
✓	37	50889	905 0889.0	Backup Ring, Spiral, 1.62 x 1.99 x .033" .....	1
	38	32509	503 2509.4	Ram .....	1
	39	32519	503 2519.1	Spring, Compression, 1.49 x 1.82 x 6.06" .....	1
▼✓	40	53958	905 3958.3	Seal, 2.562", Quad Ring .....	1
▼✓	41	53470	905 3470.0	Backup Ring, Single Turn, 2.37 x 2.55 x .050" Teflon .....	1
▼	42	35674	503 5674.7	Cap, Cylinder .....	1
▼✓	43	50055	905 0055.5	Backup Ring, Spiral, .187 x .312 x .055" Teflon .....	1
▼✓	44	51046	905 1046.1	O-ring, .187 x .312 x .062" Nitrile .....	1
▼	46	35687	503 5687.9	Block, Pump.....	1
▼✓	47	50678	905 0678.2	Ball, Steel, .187" Diameter, Grade #25 (same as item 51) .....	1
▼✓	48	16141	501 6141.5	Spring, Compression, .194 x .214 x .500" .....	1
▼	49	35691	503 5691.7	Body, Inlet Check.....	1
▼✓	50	51253	905 1253.7	O-Ring, .218 x .343 x .062" Nitrile .....	1
▼✓	51	50678	905 0678.2	Ball, Steel, .187" Diameter, Grade #25 (same as item 47) .....	1
▼✓	52	51204	905 1204.9	Pin, Roll, .062 x .375" .....	1
▼✓	53	50679	905 0679.0	Ball, Steel, .250" Diameter, Grade #25.....	1
▼✓	54	35693	503 5693.3	Washer, Flat, .156 x .281 x .062" Copper .....	1
▼✓	55	35694	503 5694.1	Washer, Flat, .204 x .375 x .062" Copper .....	1
▼✓	56	53689	905 3689.4	O-ring, .334 x .475 x .070" (same as items 31 and 63) .....	1
▼✓	57	53959	905 3959.1	Spring, Compression, .188 x .240 x .625" (same as item 78) .....	1
▼	58	35692	503 5692.5	Sleeve, Check Ball.....	1
	59	50581	905 0581.6	Screw, Cap, 1/4-20 x 1.00" Socket Head. ....	4
▼✓	60	32535	503 2535.3	Washer, Flat, .260 x .390 x .046" Copper .....	4
▼✓	62	50883	905 0883.1	Backup Ring, Spiral, .375 x .485 x .027" Teflon .....	1

**Parts List — Serial Code YM (cont'd)**

	KEY	UPC NO. 78-3310-	PART NO.	DESCRIPTION	QTY.
▼✓	63	53689	905 3689.4	O-ring, .334 x .475 x .070" (same as items 31 and 56)	1
▼✓	64	53957	905 3957.5	Seal, 1.00", Quad Ring	1
▼✓	65	51272	905 1272.3	Backup Ring, Spiral, .750 x .992 x .027"	1
	66	32503	503 2503.5	Plunger, Lo Pressure	1
▼✓	67	53477	905 3477.8	Washer, Flat, .156 x .250 x .046" Copper	1
	68	32504	503 2504.3	Plunger, Hi Pressure	1
▼✓	69	50722	905 0722.3	O-ring, .114 x .250 x .068"—70D Nitrile	1
	70	35690	503 5690.9	Shaft, Pressure Release	1
▼✓	71	50168	905 0168.3	O-ring, .364 x .500 x .068"—90D Nitrile	1
	72	35696	503 5696.8	Body, Pressure Release	1
✓	73	32534	503 2534.5	Spring, Compression, .164 x .240 x .750"	1
✓	74	50436	905 0436.4	Ball, Steel, .281 Diameter, Grade #25	1
▼✓	77	50452	905 0452.6	Ball, Steel, .218 Diameter, Grade #25	1
✓	78	53959	905 3959.1	Spring, Compression, .188 x .240 x .625" (same as item 57)	1
▼✓	79	53960	905 3960.5	Plug, O-Ring, 5/16-24 x .380"	1
X	80	32523	503 2523.0	Body, Pressure-Adjusting Valve	1
X	81	32789	503 2789.5	Plunger, Valve	1
X ▼ ✓	82	03421	500 3421.9	Washer, Flat, .440 x .687 x .064" Copper	1
	83	35699	503 5699.2	Guide, Roller	1
	84	32562	503 2562.0	Rod, Stepped	1
X ✓	85	32572	503 2572.8	Spring, Compression, .178 x .322 x .875"	1
X	86	35695	503 5695.0	Cap, Valve Spring, .343 x .432 x .435"	1
● ▼	87	35682	503 5682.8	Cap, Relief Valve	1
	88	32564	503 2564.7	Roller, Valve Adjustment, .197 x .247"	1
	89	32559	503 2559.0	Slide, Moving	2
● ▼	90	35681	503 5681.0	Plate, Valve	1
✓	91	51462	905 1462.9	Screw, Machine, #10-32 x 1.25" Round Head	2
● ▼ ✓	92	51686	905 1686.9	Nut, Hex, #10-32 Full	1
● ▼ ✓	93	53961	905 3961.3	Screw, #10-32, Socket Set	1
▼	94	35684	503 5684.4	Rod Unit, Driving	1
	95	32557	503 2557.4	Screw, Rod Retaining	1
✓	96	51245	905 1245.6	Screw, Set, 1/4-20 x .250" Flat Point Socket	1
▼ ✓	97	53960	905 3960.5	Plug, O-Ring, 5/16-24 x .380"	1
	98			RTV	
	101			RTV	
	102	33730	503 3730.0	Spacer, .549 x .997 x .025" Stainless Steel	*
▲	103	35462	503 5462.0	Decal, Warning	1
✓	104	22726	502 2726.2	Filter, Oil	1
*Quantity of one or two, if necessary. To determine if this item is necessary, see Die Replacement procedure.					
<b>Decals</b>		32792	503 2792.5	Decal, Identification	1
		35463	503 5463.9	Decal, Connector Chart	1
		06233	500 6233.6	Decal, Safety Lid Liner	1
		06243	500 6243.3	Decal, Operating Inst.	1
<b>Accessory</b>		32791	503 2791.7	Case, Carrying	1
<b>Repair Kits and Supplies</b>					
		32891	503 2891.3	Slug Test Kit (includes one Go/No Go Gauge and 30 test slugs)	
✓		33013	503 3013.6	Hydraulic Repair Kit	
X		33737	503 3737.8	Relief Valve Repair Kit	
▷		35671	503 5671.2	Pump Handle Unit	
■		36149	503 6149.0	Cylinder and Die Head Repair Kit	
●		36150	503 6150.3	Valve Cap and Cover Repair Kit	
◆		36151	503 6151.1	Reservoir Handle Repair Kit	
▲		36152	503 6152.0	Pump Handle Repair Kit	
▼		36153	503 6153.8	Pump Block Repair Kit	

**TRANSCAT**<sup>®</sup>

 Visit us at [Transcat.com](http://Transcat.com)!

35 Vantage Point Drive // Rochester, NY 14624 // Call 1.800.800.5001

**GREENLEE** **TEXTRON**