

**CONNECTOR**  
**DESIGNATORS**  
**A-F-H-L-S**  
**ROTATABLE**  
**COUPLING**

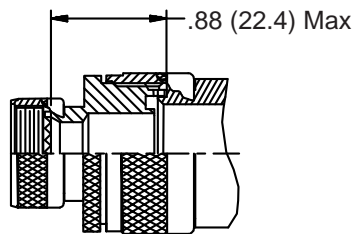
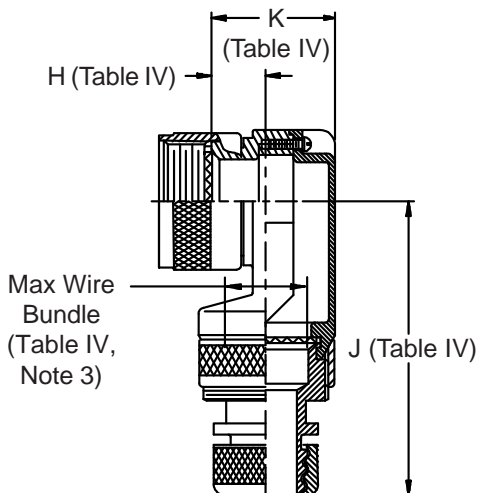
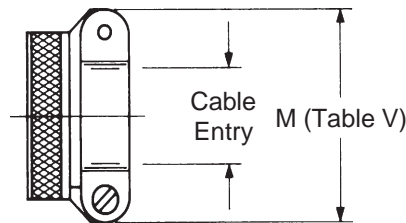
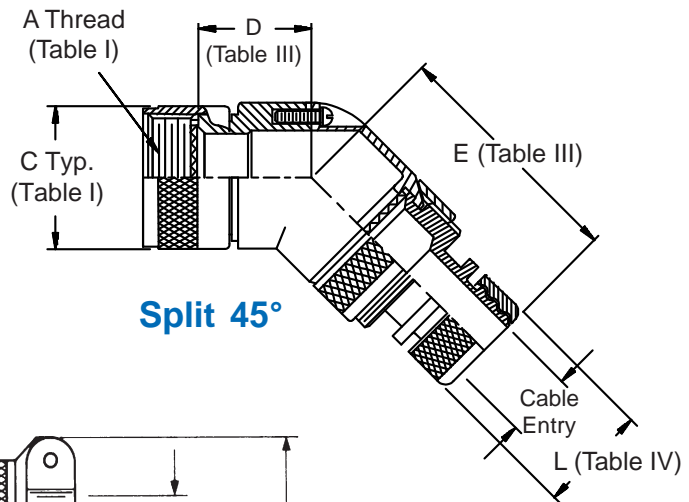
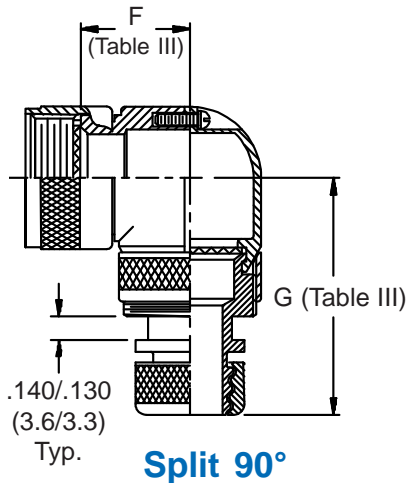
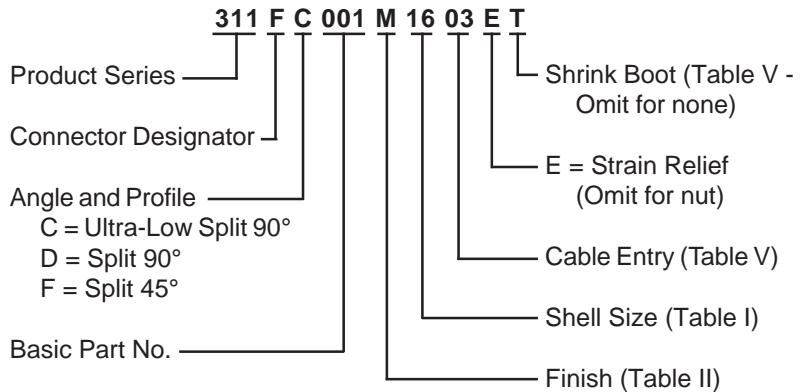

GLENAIR SYMBOL FINISH	
B	Cadmium Plate, Olive Drab
M	Electroless Nickel
NF	Cadmium Plate, Olive Drab Over Electroless Nickel

See Inside Back Cover for Complete Finish Information and Additional Finish Options

**311-001**  
**Lamp-Base Thread EMI/RFI Shrink Boot Adapter**  
**with Strain Relief and Optional Shrink Boot**  
**Rotatable Coupling - Split Shell**



See inside back cover fold-out or pages 13 and 14 for unabridged Tables I and II.

**TABLE III: SPLIT 90° and SPLIT 45°**

SHELL SIZE		D	E	F	G
A-F-L-S	H	Max	Max	Max	Max
08	09	.440 (11.2)	1.740 (44.2)	.680 (17.3)	1.680 (42.7)
10	11	.500 (12.7)	1.800 (45.7)	.750 (19.1)	1.740 (44.2)
12	13	.560 (14.2)	1.870 (47.5)	.810 (20.6)	1.810 (46.0)
14	15	.620 (15.7)	1.900 (48.3)	.870 (22.1)	1.840 (46.7)
16	17	.680 (17.3)	2.000 (50.8)	.930 (23.6)	1.940 (49.3)
18	19	.750 (19.1)	2.060 (52.3)	1.000 (25.4)	2.000 (50.8)
20	21	.820 (20.8)	2.120 (53.8)	1.060 (26.9)	2.060 (52.3)
22	23	.880 (22.4)	2.180 (55.4)	1.120 (28.4)	2.120 (53.8)
24	25	.940 (23.9)	2.240 (56.9)	1.180 (30.0)	2.340 (59.4)

**TABLE IV: ULTRA LOW-PROFILE SPLIT 90°**

SHELL SIZE		H	J	K	Max Wire
A-F-L-S	H	Ref.	Max	Max	Bundle
08	09	.340 (8.6)	2.020 (51.3)	.681 (17.3)	.250 (6.4)
10	11	.270 (6.9)	2.180 (55.4)	.731 (18.6)	.375 (9.5)
12	13	.270 (6.9)	2.180 (55.4)	.731 (18.6)	.375 (9.5)
14	15	.280 (7.1)	2.250 (57.2)	.831 (21.1)	.500 (12.7)
16	17	.420 (10.7)	2.300 (58.4)	.981 (24.9)	.625 (15.9)
18	19	.640 (16.3)	2.330 (59.2)	1.181 (30.0)	.625 (15.9)
20	21	.640 (16.3)	2.330 (59.2)	1.181 (30.0)	.625 (15.9)
22	23	.540 (13.7)	2.480 (63.0)	1.181 (30.0)	.750 (19.1)
24	25	.540 (13.7)	2.480 (63.0)	1.181 (30.0)	.750 (19.1)

**TABLE V: CABLE ENTRY AND SHRINK BOOT**

Dash No.	L Max	M Max	Cable Entry Max	Shrink Boot
01	.448 (11.4)	.781 (19.8)	.125 (3.2)	n/a
02	.515 (13.1)	.968 (24.6)	.250 (6.4)	770-001S103
03	.640 (16.3)	1.046 (26.6)	.375 (9.5)	770-001S103
04	.765 (19.4)	1.156 (29.4)	.500 (12.7)	770-001S104
05	.920 (23.4)	1.219 (31.0)	.625 (15.9)	770-001S104
06	1.015 (25.8)	1.343 (34.1)	.750 (19.1)	770-001S105
07	1.140 (29.0)	1.469 (37.3)	.875 (22.2)	770-001S106
08	1.265 (32.1)	1.594 (40.5)	1.000 (25.4)	770-001S106
09	1.432 (36.4)	1.719 (43.7)	1.125 (28.6)	770-001S107
10	1.515 (38.5)	1.844 (46.8)	1.250 (31.8)	770-001S107

1. Cable Entry is defined as the accommodation range for the wire bundle or cable. Dimensions shown are not intended for inspection criteria.
2. Metric dimensions (mm) are indicated in parentheses.
3. When maximum entry (page 21) is exceeded, Style 2 will be supplied (not available for Function C). Dimensions D, E, F, & G will not apply. Please consult factory.
4. See Shrink Boot Reference Information (pages 40 and 41).
5. Angular function "C", low-profile split elbow, not available with "S" connector designator.