

# MATING CONDITIONS

Float mount tolerance guide

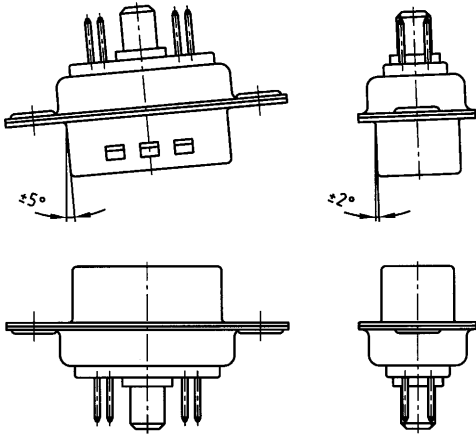

Rigid mount tolerance guide

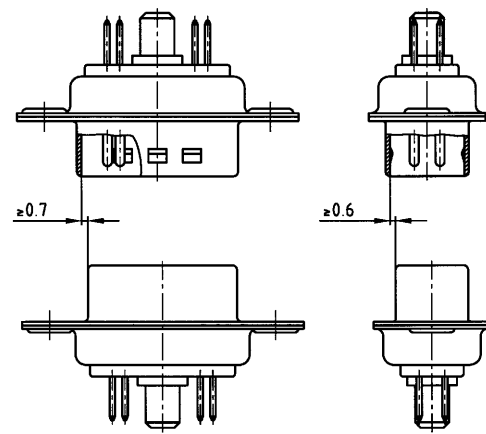

Rigid mount vertical to tolerance guide

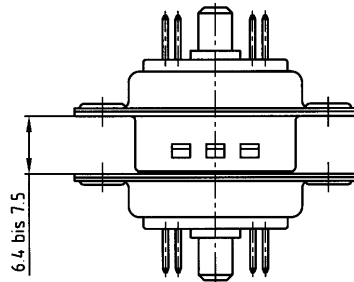

## PANEL CUT-OUT

Rear panel mounting

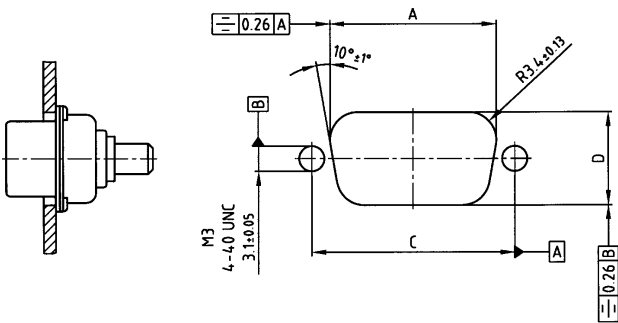

Front panel mounting

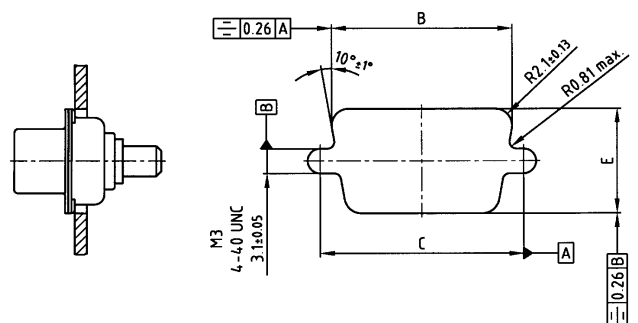

Shell size	A ± 0,13	B ± 0,13	C ± 0,13	D ± 0,13	E ± 0,13
1	20.50	22.20	25.00	11.40	13.00
2	28.80	30.50	33.30	11.40	13.00
3	42.50	44.30	47.04	11.40	13.00
4	59.10	60.70	63.50	11.40	13.00
5	56.30	58.30	61.10	14.10	15.80

## PART NUMBER CREATOR

3 003W3 S X X 6 1 A 1 O X

**Product Line**

3	= Shell steel tin plated	
1	= Brass tin plated*	
A	= Stainless steel*	*on request

**Shell size and design**

1	= 5W1, 2W2C	
2	= 3W3, 7W2, 11W1, 3W3C	
3	= 5W5, 9W4, 13W3, 17W2, 21W1	
4	= 8W8, 13W6, 17W5, 21WA4, 25W3, 27W2	
5	= 24W7, 36W4, 43W2, 47W1	Empty positions ADD „0“ = 003W3

**Contact type**

P	= Plug connector
S	= Socket connector

**Oberfläche/Quality class for signal contacts**

A	= Quality class 3 = 50 mating cycles
B	= Quality class 2 = 200 mating cycles
C	= Quality class 1 = 500 mating cycles
J	= Special application => 500 mating cycles (on request)
X	= Crimp and 3W3, 5W5, 8W8, 2W2C, 3W3C (no contacts are supplied with the connector)

**Termination only for signal contacts**

K	= Crimp without contacts	U	= Solder pin, angled, .370" / 9.40 mm
M	= Solder cup	W*	= Solder pin, angled, .450" / 11.43 mm
N	= Wire wrap, .500" / 12.7 mm	X	= 3W3, 5W5, 8W8, 2W2C, 3W3C
P	= Press fit	Z*	= Solder pin, angled, .540" / 13.84 mm
R	= Solder pin, straight, .220" / 5.6 mm	*	= please contact us
T	= Solder pin, angled, .280" / 7.19 mm		

**Termination for high power or coaxial contacts**

C1	= Solder/Crimp angled 10 A	75 / 58 = Solder pin, angled 40 A	
C2	= Solder/Crimp angled 20 A	77 / 60 = Solder pin, angled 40 A	
C3	= Solder/Crimp angled 30 A	85 / 65 = Solder pin, angled 30 A	
C4	= Solder/Crimp angled 40 A	81 / 66 = Solder pin, angled 20 A	
61 / 41	= Solder cup 10 A	82 / 67 = Solder pin, angled 30 A	
62 / 42	= Solder cup 20 A	G7 / 76 = 3 Solder pins Straight 50 Ω	
63 / 43	= Solder cup 30 A	G9 / 78 = 3 Solder pins angled 50 Ω	
64 / 44	= Solder cup 40 A	H1 / 79 = 3 Solder pins angled 50 Ω	
68 / 48	= Solder pin, straight 20 A, D= .077" / 1.95 mm	H4 / 80 = 5 Solder pins angled 50 Ω	
69 / 49	= Solder pin, straight 20 A, D= .102" / 2.60 mm	G8 / 86 = 3 Solder pins Straight 75 Ω	
70 / 50	= Solder pin, straight 20 A, D= .110" / 2.85 mm	H2 / 88 = 3 Solder pins angled 75 Ω	
71 / 51	= Solder pin, straight 30 A, D= .130" / 3.18 mm	H3 / 89 = 3 Solder pins angled 75 Ω	
72 / 52	= Solder pin, straight 40 A, D= .150" / 3.75 mm	H5 / 90 = 5 Solder pins angled 75 Ω	
59 / 55	= Solder pin, angled 15 A	91	= Screw termination 20 A
73 / 56	= Solder pin, angled 20 A	99	= no high power, coax or crimp contacts loaded
74 / 57	= Solder pin, angled 30 A		Coaxial contacts with cable termination must be ordered separately.

**Mounting style**

A1	= Riveted	E6	= 4-40 UNC threaded rear spacer with PCB clip, PCB .126" / 3.20 mm
A2	= M3 threaded insert	F1	= M3 clip and threaded rear spacer with PCB clip, PCB .063" / 1.60 mm
A3	= 4-40 UNC threaded insert	F2	= 4-40 UNC clip and threaded rear spacer with PCB clip, PCB .063" / 1.60 mm
A4	= M3 threaded rear spacer	F3	= M3 clip and threaded rear spacer with PCB clip, PCB .091" / 2.30 mm
A5	= 4-40 UNC threaded rear spacer	F4	= 4-40 UNC clip and threaded rear spacer with PCB clip, PCB .091" / 2.30 mm
A6	= Float fastening	F5	= M3 clip and threaded rear spacer with PCB clip, PCB .126" / 3.20 mm
A7	= Threaded rear spacer for M3 press fit	F6	= 4-40 UNC clip and threaded rear spacer with PCB clip, PCB .126" / 3.20 mm
A8	= Threaded rear spacer for 4-40 UNC press fit	G1	= Metal bracket, M3 threaded insert for .370" / 9.40 mm
C1	= M3 threaded rear spacer with PCB clip, PCB .063" / 1.60 mm	G2	= Metal bracket, 4-40 UNC threaded insert for .370" / 9.40 mm
C2	= 4-40 UNC threaded rear spacer with PCB clip, PCB .063" / 1.60 mm	G3	= Metal bracket, M3 threaded insert and clip for .370" / 9.40 mm
C3	= M3 threaded rear spacer with PCB clip, PCB .091" / 2.30 mm	G4	= Metal bracket, 4-40 UNC threaded insert and clip for .370" / 9.40 mm
C4	= 4-40 UNC threaded rear spacer with PCB clip, PCB .091" / 2.30 mm	H1	= Metal bracket, M3 threaded lock for .370" / 9.40 mm
C5	= M3 threaded rear spacer with PCB clip, PCB .126" / 3.20 mm	H2	= Metal bracket, 4-40 UNC threaded lock for .370" / 9.40 mm
C6	= 4-40 UNC Threaded rear spacer with PCB clip, PCB .126" / 3.20 mm	H3	= Metal bracket, M3 threaded lock and clip for .370" / 9.40 mm
D1	= M3 clip and threaded rear spacer with PCB clip, PCB .063" / 1.60 mm	H4	= Metal bracket, 4-40 UNC threaded lock and clip for .370" / 9.40 mm
D2	= 4-40 UNC clip and threaded rear spacer with PCB clip, PCB .063" / 1.60 mm	N1	= Metal bracket, M3 threaded insert for .280" / 7.19 mm
D3	= M3 clip and threaded rear spacer with PCB clip, PCB .091" / 2.30 mm	N2	= Metal bracket, 4-40 UNC threaded insert for .280" / 7.19 mm
D4	= 4-40 UNC clip and threaded rear spacer with PCB clip, PCB .091" / 2.30 mm	N3	= Metal bracket, M3 threaded insert and clip for .280" / 7.19 mm
D5	= M3 clip and threaded rear spacer with PCB clip, PCB .126" / 3.20 mm	N4	= Metal bracket, 4-40 UNC threaded insert and clip for .280" / 7.19 mm
D6	= 4-40 UNC clip and threaded rear spacer with PCB clip, PCB .126" / 3.20 mm	P1	= Metal bracket, M3 threaded lock for .280" / 7.19 mm
E1	= M3 threaded rear spacer with PCB clip, PCB .063" / 1.60 mm	P2	= Metal bracket, 4-40 UNC threaded lock for .280" / 7.19 mm
E2	= 4-40 UNC threaded rear spacer with PCB clip, PCB .063" / 1.60 mm	P3	= Metal bracket, M3 threaded lock and clip for .280" / 7.19 mm
E3	= M3 threaded rear spacer with PCB clip, PCB .091" / 2.30 mm	P4	= Metal bracket, 4-40 UNC threaded lock and clip for .280" / 7.19 mm
E4	= 4-40 UNC threaded rear spacer with PCB clip, PCB .091" / 2.30 mm	W1	= Threaded rear spacer with M3 press in pin
E5	= M3 threaded rear spacer with PCB clip, PCB .126" / 3.20 mm	W2	= Threaded rear spacer with 4-40 UNC press in pin

OX = Standard

# TECHNICAL DATA

Materials	Connector with signal contacts	Coaxial contacts	High power contacts	High voltage contacts
Insulator Green standard / black crimp	PBTP, GV (UL94 V-0)			
Shell	steel tin plated Brass or stainless steel on request			
Contact plating	Gold plated over nickel			
Contact material	CU alloy			
PCB clip		CU alloy	CU alloy	PI
Insulator	PTFE/PBTP/PI		PTFE	
<b>Mechanical and electrical characteristics</b>				
Current rating	7.5 A (UL) / 5 A (CSA, VDE)			
Test voltage between 2 contacts contact and shell	1000 V, 50Hz 1 min.			
Resistance between mated contacts	2.7m $\Omega$			
Insulation resistance	5G $\Omega$	10 <sup>7</sup> m $\Omega$	5G $\Omega$	2x10 <sup>7</sup> m $\Omega$
Contact resistance	10 <sup>16</sup> $\Omega$ cm			
Dielectric impedance	50KV/mm			
Characteristic impedance		50/75		
Contact resistance inner/outer conductor	2.7m $\Omega$	2.7m $\Omega$	1m $\Omega$	2.7m $\Omega$
VSWR-value at according MIL-C-39012	1.2GHz 1.5GHz 2.0GHz		1.2 1.3 1.5	
Dielectric voltage		750V 50Hz		3.8kV
Frequency range		0-2GHz		
Working voltage	250 V	250 V		max. 2.8kV
Temperature range	-55°C to +125°C			
Insertion force per contact	3,4N	7N	7N	5N
Extraction force per contact	0,2N	7N	ca. 5N	ca. 2.5N
Mating cycles	A = Quality class 3 = 50 mating cycles, B = Quality class 2 = 200 mating cycles, C = Quality class 1 = 500 mating cycles			

Technical alterations are subject to change without notice.

# TECHNICAL INFORMATIONS

## SKIN EFFECT

Alternating currents do not uniformly occupy the entire cross section of the conductor, rather inductance effect in the conductor deflects the current towards the surface of the conductor, whereby this deflection increases with the frequency.

The resistive attenuation of a transmission line increases with the frequency as a result of this skin effect.

The skin depth (equivalent thickness of the layer in which current flows) can be determined using

$$\delta = \frac{1}{\sqrt{f \pi \sigma \mu_0 \mu_r}}$$

f = frequency

$\sigma$  = conductivity of the conductor material

$\sigma_{Ag} = 62 \times 10^6 \text{ S/m}$

$\sigma_{Cu} = 58 \times 10^6 \text{ S/m}$

$\mu_0 = 1,256 \cdot 10^{-6} \text{ Vs / Am}$

$\mu_r$  ... relative permeability constant for the employed material

## VSWR-VALUE

The ratio between the value of the largest and the smallest voltages on a loss-free line is known as the ripple or voltage standing wave ratio s (where  $1 \leq s < \infty$ ). The reciprocal value of the VSWR is known as the inverse voltage standing wave ratio m (where  $0 < m \leq 1$ ).

(VSWR = Voltage standing wave ratio)

The value of s is linked with the → reflection coefficient r on s transmission line according to the equation

$$s = \frac{(1 + |r|)}{(1 - |r|)}$$

## CURRENT RATING

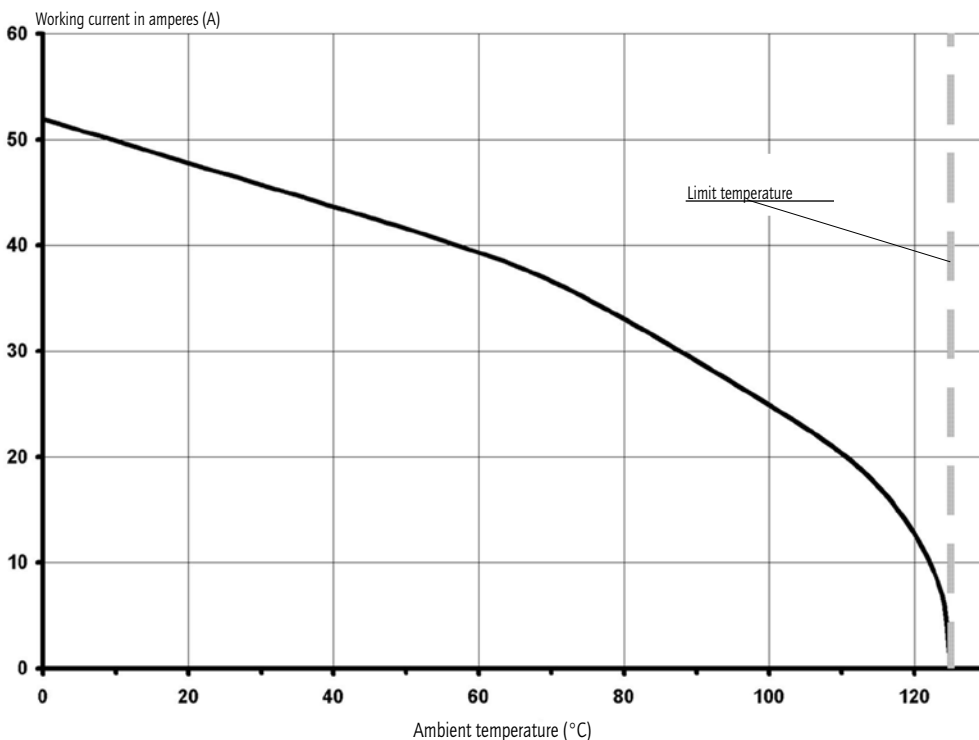

# CRIMPING INSTRUCTIONS FOR COAX CONTACTS

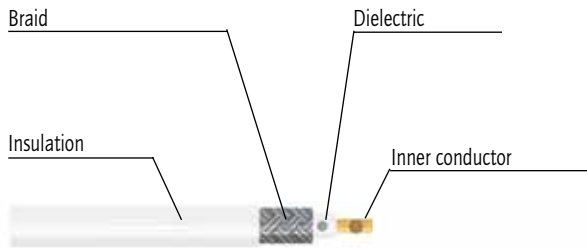

Strip the wire



Slide sleeve over coax cable



Crimp the inner contact on the inner conductor



Snap the inner contact into the outer contact



Slide braid over outer contact



Crimp the sleeve on to outer contact

# PIN CONFIGURATION – MATING SIDE OF SOCKET CONNECTOR

**SHELL SIZE 1**

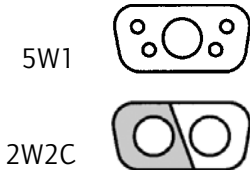

**SHELL SIZE 2**

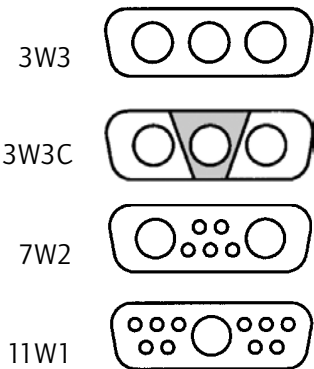

**SHELL SIZE 3**

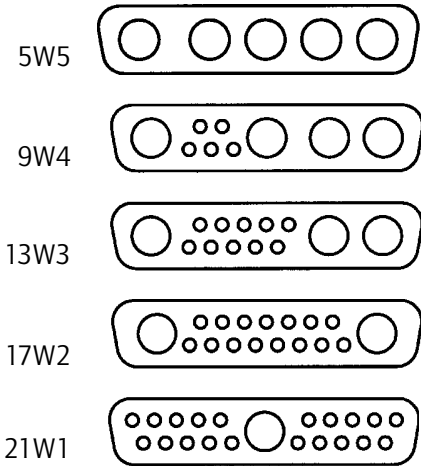

**SHELL SIZE 4**

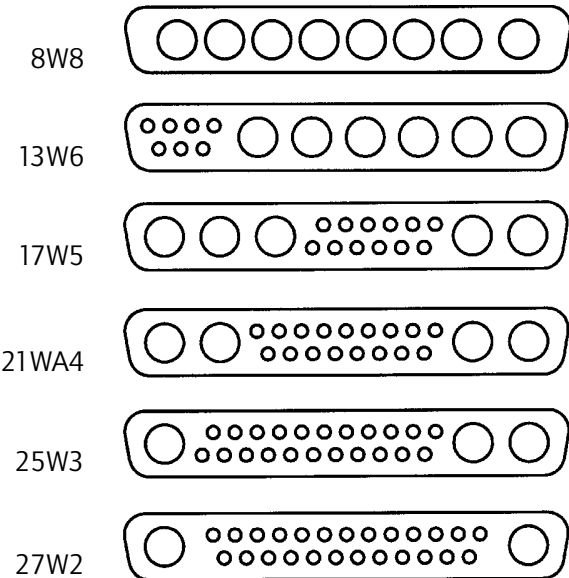

**SHELL SIZE 5**

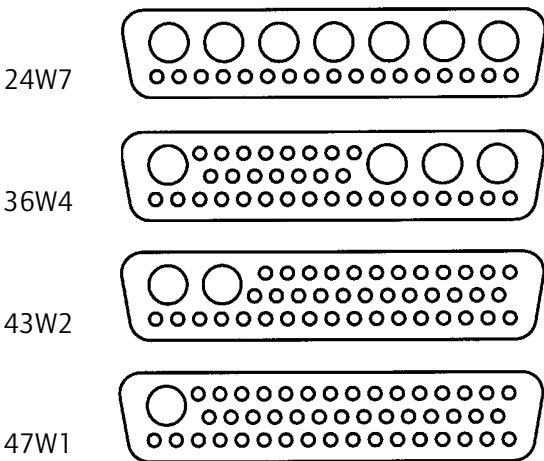

Connectors 3W3, 5W5 and 8W8 with female insulators: Socket contacts are fingerprobe safe according to UL 1950 and CSA 22.2.950.