

## Electronic housing - UM108-FE - 2959463

Please be informed that the data shown in this PDF Document is generated from our Online Catalog. Please find the complete data in the user's documentation. Our General Terms of Use for Downloads are valid (<http://phoenixcontact.com/download>)

Foot element, 107.5 mm wide, for mounting on NS 32 or NS 35/7.5, below profile housing UM 108.



### Your advantages

- ✓ Lateral elements with potential ground contact available from the PCB to the DIN rail (EMC)
- ✓ Fast assembly on standard NS 35 or NS 32 DIN rails
- ✓ Flexible size and shape
- ✓ Inexpensive as a result of reducing the number of separate housing parts
- ✓ Wide range of options for external conductor connection
- ✓ High degree of mechanical stability by screwing the lateral elements to the profile
- ✓ The modules can be marked with Phoenix Contact marking material using the marking grooves in the press-drawn section

### Key Commercial Data

Packing unit	1 pc
Minimum order quantity	10 pc
GTIN	
GTIN	4017918086121
Weight per Piece (excluding packing)	8.200 g
Custom tariff number	39269097
Country of origin	Poland

### Technical data

#### General

Housing type	Component housing
Housing material	Polyamide

# Electronic housing - UM108-FE - 2959463

## Technical data

### General

Color (RAL)	green
-------------	-------

### Standards and Regulations

Flammability rating according to UL 94	V0
--	----

### Environmental Product Compliance

China RoHS	Environmentally friendly use period: unlimited = EFUP-e
	No hazardous substances above threshold values

## Drawings

Dimensional drawing

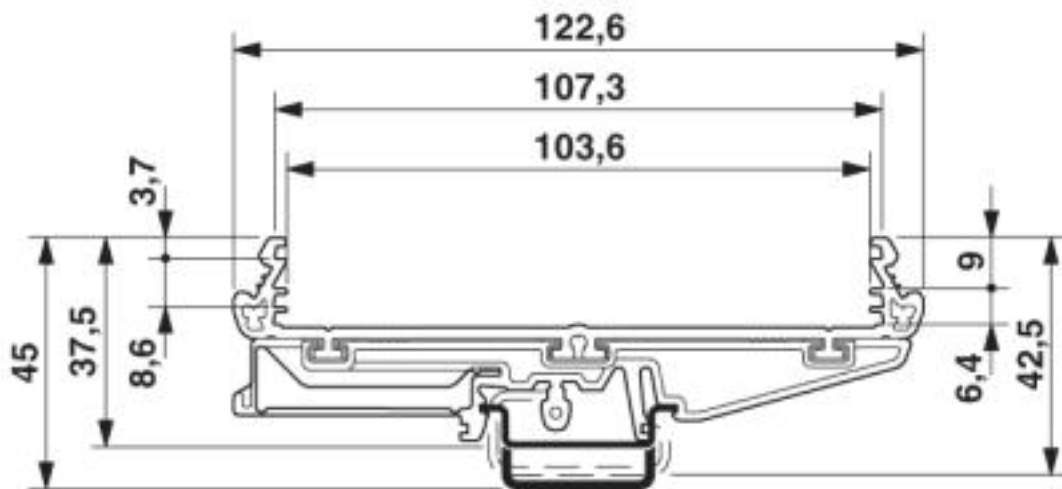

## Electronic housing - UM108-FE - 2959463

Dimensional drawing

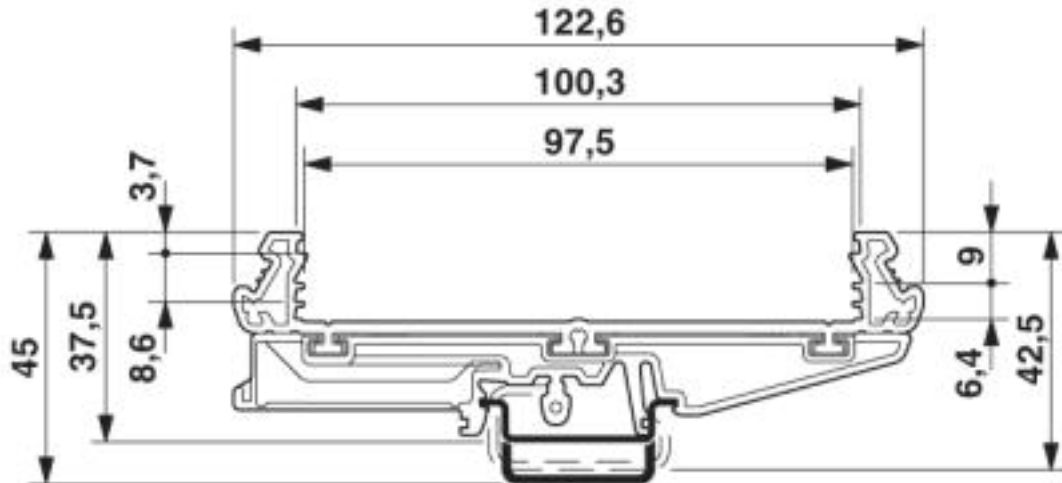

### Classifications

#### eCl@ss

eCl@ss 4.0	27180400
eCl@ss 4.1	27180400
eCl@ss 5.0	27180500
eCl@ss 5.1	27180500
eCl@ss 6.0	27180800
eCl@ss 7.0	27182701
eCl@ss 8.0	27182701
eCl@ss 9.0	27182701

#### ETIM

ETIM 2.0	EC001031
ETIM 3.0	EC001031
ETIM 4.0	EC001031
ETIM 5.0	EC002779
ETIM 6.0	EC002779
ETIM 7.0	EC002779

#### UNSPSC

UNSPSC 6.01	31261501
UNSPSC 7.0901	31261501
UNSPSC 11	31261501
UNSPSC 12.01	31261501

# Electronic housing - UM108-FE - 2959463

## Classifications

### UNSPSC

UNSPSC 13.2	31261501
-------------	----------

## Approvals

### Approvals

---

#### Approvals

UL Recognized / EAC

---

Ex Approvals

---

## Approval details

UL Recognized		<a href="http://database.ul.com/cgi-bin/XYV/template/LISEXT/1FRAME/index.htm">http://database.ul.com/cgi-bin/XYV/template/LISEXT/1FRAME/index.htm</a>	FILE E 240868
---------------	--	---	---------------

EAC			B.01742
-----	---	--	---------

---