



GUARDIAN Electric Manufacturing

ISO 9001 / AS9100 Certified Company

Woodstock, IL 60098 Ph. (815)334-3600 Fax (815)337-0377

Or visit us at our website www.guardian-electric.com

Model 28P Push DC Frame Solenoid

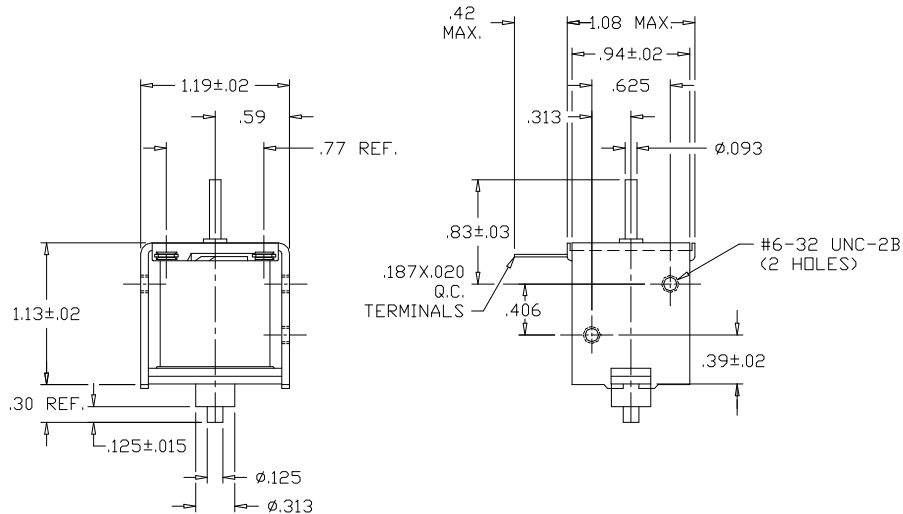

Solenoid shown energized and fully seated.

Spring kits are available (consult factory).

Total Weight: 3.5 oz.

Plunger Weight: .5 oz.

Model No.	Part No.	Duty Cycle	Voltage	Resistance (Ω)	Power (W)	Current
28P-I-12D	A420-065593-00	Intermittent	12VDC	11.9	12.7	1.01 A
28P-C-12D	A420-065592-00	Continuous	12VDC	29.8	5.1	403 mA
28P-I-24D	A420-065595-00	Intermittent	24VDC	47.4	12.8	506 mA
28P-C-24D	A420-065594-00	Continuous	24VDC	116	5.2	207 mA

When ordering, please refer to Part No., as listed above.

Consult factory for custom configurations.

Stroke (in.)	Push Force (oz.)								Holding Force (oz.)
	0.050	0.125	0.250	0.375	0.500	0.625	0.750	1.000	
Continuous Duty	25	10	4	2	1	n/a	n/a	n/a	76
Intermittent Duty	32	12	7	4	2	n/a	n/a	n/a	92

UL Recognition

Recognized under the  Component Recognition Program of **Underwriters Laboratories, Inc.**

Continuous Duty

100% 'On' Time

Intermittent Duty

25% 'On' Time, (100 Seconds 'On' Max. Followed By 300 Seconds 'Off' Min.)

RoHS

These parts comply with **RoHS** Directive 2002/95/EC