

Signal conditioner - MINI MCR-SL-I-U-4 - 2813538

Please be informed that the data shown in this PDF Document is generated from our Online Catalog. Please find the complete data in the user's documentation. Our General Terms of Use for Downloads are valid (<http://phoenixcontact.com/download>)



MCR 3-way isolating amplifier, for electrical isolation of analog signals, with screw connection, input signal: 4 mA ... 20 mA, output signal: 0 A ... 10 V

Product Features

- Power supply possible via the foot element (TBUS)
- Low power consumption
- Entry-level alternative to configurable signal conditioners
- Highly-compact isolating amplifier for electrical isolation, conversion, amplification, and filtering of standard analog signals
- 3-way isolation
- Fixed signal combinations



Key Commercial Data

Packing unit	1 pc
Weight per Piece (excluding packing)	80.0 g
Custom tariff number	85437090
Country of origin	Germany

Technical data

Note

Utilization restriction	EMC: class A product, see manufacturer's declaration in the download area
-------------------------	---

Dimensions

Width	6.2 mm
Height	93.1 mm
Depth	102.5 mm

Signal conditioner - MINI MCR-SL-I-U-4 - 2813538

Technical data

Ambient conditions

Ambient temperature (operation)	-20 °C ... 65 °C
Ambient temperature (storage/transport)	-40 °C ... 85 °C
Maximum altitude	≤ 2000 m
Degree of protection	IP20

Input data

Number of inputs	1
Configurable/programmable	no
Current input signal	4 mA ... 20 mA
Max. input current	50 mA
Input resistance current input	approx. 50 Ω

Output data

Number of outputs	1
Configurable/programmable	no
Voltage output signal	0 V ... 10 V
Max. output voltage	12.5 V
Short-circuit current	approx. 2 mA
Load/output load voltage output	≥ 10 kΩ

Power supply

Nominal supply voltage	24 V DC
Supply voltage range	19.2 V DC ... 30 V DC (The DIN rail bus connector (ME 6,2 TBUS-2 1,5/5-ST-3,81 GN, Order No. 2869728) can be used to bridge the supply voltage. It can be snapped onto a 35 mm DIN rail according to EN 60715))
Max. current consumption	< 9 mA
Power consumption	< 200 mW

Connection data

Connection method	Screw connection
Conductor cross section solid min.	0.2 mm ²
Conductor cross section solid max.	2.5 mm ²
Conductor cross section AWG min.	26
Conductor cross section AWG max.	12
Conductor cross section flexible min.	0.2 mm ²
Conductor cross section flexible max.	2.5 mm ²
Stripping length	12 mm
Screw thread	M3

General

No. of channels	1
-----------------	---

Signal conditioner - MINI MCR-SL-I-U-4 - 2813538

Technical data

General

Maximum transmission error	≤ 0.1 % (of final value)
Maximum temperature coefficient	< 0.01 %/K
Temperature coefficient, typical	< 0.002 %/K
Limit frequency (3 dB)	approx. 100 Hz
Step response (10-90%)	approx. 3.5 ms
Electrical isolation	Basic insulation according to EN 61010
Overvoltage category	II
Degree of pollution	2
Rated insulation voltage	50 V AC/DC
Test voltage, input/output/supply	1.5 kV (50 Hz, 1 min.)
Electromagnetic compatibility	Conformance with EMC Directive 2004/108/EC (valid until 19.04.2016) / 2014/30/EU (valid from 20.04.2016)
Noise emission	EN 61000-6-4
Noise immunity	EN 61000-6-2 When being exposed to interference, there may be minimal deviations.
Color	green
Housing material	PBT
Mounting position	any
Assembly instructions	The T connector can be used to bridge the supply voltage. It can be snapped onto a 35 mm DIN rail according to EN 60715.
Conformance	CE-compliant
ATEX	# II 3 G Ex nA IIC T4 Gc X
UL, USA / Canada	UL 508 Recognized
	Class I, Div. 2, Groups A, B, C, D T5 applied for
GL	GL EMC 2 D

EMC data

Designation	Electromagnetic RF field
Standards/regulations	EN 61000-4-3
Typical deviation from the measuring range final value	5 %
Designation	Fast transients (burst)
Standards/regulations	EN 61000-4-4
Typical deviation from the measuring range final value	5 %
Designation	Conducted interferences
Standards/regulations	EN 61000-4-6
Typical deviation from the measuring range final value	5 %

Standards and Regulations

Electromagnetic compatibility	Conformance with EMC Directive 2004/108/EC (valid until 19.04.2016) / 2014/30/EU (valid from 20.04.2016)
-------------------------------	--

Signal conditioner - MINI MCR-SL-I-U-4 - 2813538

Technical data

Standards and Regulations

Noise emission	EN 61000-6-4
Connection in acc. with standard	CUL
Designation	Electromagnetic RF field
Standards/regulations	EN 61000-4-3
	EN 61000-4-4
Designation	Conducted interferences
Standards/regulations	EN 61000-4-6
Electrical isolation	Basic insulation according to EN 61010
Conformance	CE-compliant
ATEX	# II 3 G Ex nA IIC T4 Gc X
UL, USA / Canada	UL 508 Recognized
	Class I, Div. 2, Groups A, B, C, D T5 applied for
GL	GL EMC 2 D

Classifications

eCl@ss

eCl@ss 4.0	27210120
eCl@ss 4.1	27210120
eCl@ss 5.0	27210120
eCl@ss 5.1	27210120
eCl@ss 6.0	27210120
eCl@ss 7.0	27210120
eCl@ss 8.0	27210120

ETIM

ETIM 2.0	EC001485
ETIM 3.0	EC001485
ETIM 4.0	EC001485
ETIM 5.0	EC002653

UNSPSC

UNSPSC 6.01	30211506
UNSPSC 7.0901	39121008
UNSPSC 11	39121008
UNSPSC 12.01	39121008
UNSPSC 13.2	39121008

Signal conditioner - MINI MCR-SL-I-U-4 - 2813538

Approvals

Approvals

Approvals

UL Recognized / cUL Recognized / GL / EAC / cULus Recognized

Ex Approvals

ATEX

Approvals submitted

Approval details

UL Recognized 

cUL Recognized 

GL

EAC

cULus Recognized 

Drawings

Signal conditioner - MINI MCR-SL-I-U-4 - 2813538

Block diagram

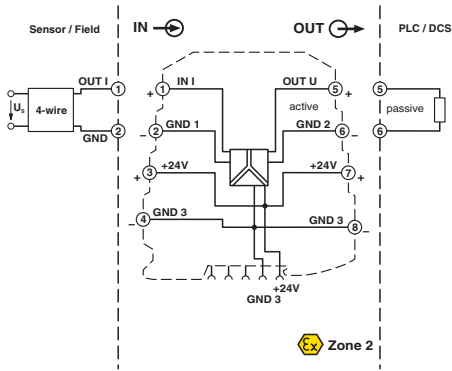

Dimensional drawing

