

Type 2 surge protection plug - VAL-MS 230 ST - 2798844

Please be informed that the data shown in this PDF Document is generated from our Online Catalog. Please find the complete data in the user's documentation. Our General Terms of Use for Downloads are valid (<http://phoenixcontact.com/download>)



Surge protection connector type 2 with high-capacity varistor for VAL-MS base element, thermal monitoring, visual fault warning. Design: 230 V AC



Key Commercial Data

Packing unit	1 pc
GTIN	 4 017918 073947
Weight per Piece (excluding packing)	42.65 g
Custom tariff number	85363010
Country of origin	Germany

Technical data

Dimensions

Height	52.4 mm
Width	17.5 mm
Depth	55.3 mm
Horizontal pitch	1 Div.

Ambient conditions

Degree of protection	IP20
Ambient temperature (operation)	-40 °C ... 80 °C
Ambient temperature (storage/transport)	-40 °C ... 80 °C
Altitude	≤ 2000 m (amsl (above mean sea level))
Permissible humidity (operation)	5 % ... 95 %
Shock (operation)	25g (half sinus / 11 ms / 3x ±X, ±Y, ±Z)

Type 2 surge protection plug - VAL-MS 230 ST - 2798844

Technical data

Ambient conditions

Vibration (operation)	5g (10 ... 500 Hz / 2.5 h / X, Y, Z)
-----------------------	--------------------------------------

General

Standards/specifications	IEC 61643-11 2011
	EN 61643-11 2012
IEC test classification	II
	T2
EN type	T2
IEC power supply system	TN
	TT
SPD design	Voltage-limiting type
Mode of protection	L-PEN
	L-N
Mounting type	On base element
Color	jet black RAL 9005
Housing material	PA 6.6
Degree of pollution	2
Flammability rating according to UL 94	V-0
Type	DIN rail module, two-section, divisible
Number of positions	1
Arrester can be tested with CHECKMASTER from software version:	From SW rev. 1.10
Surge protection fault message	optical

Protective circuit

Nominal voltage U_N	240/415 V AC (TN)
	240/415 V AC (TT)
Nominal frequency f_N	50 Hz (60 Hz)
Maximum continuous voltage U_C	275 V AC
Residual current I_{PE}	≤ 0.45 mA
Standby power consumption P_C	≤ 120 mVA
Nominal discharge current I_n (8/20) μ s	20 kA
Maximum discharge current I_{max} (8/20) μ s	40 kA
Short-circuit current rating I_{SCCR}	25 kA
Voltage protection level U_p	≤ 1.35 kV
Residual voltage U_{res}	≤ 1.35 kV (at I_n)
	≤ 1.1 kV (at 10 kA)
	≤ 1 kV (at 5 kA)
	≤ 0.9 kV (at 3 kA)

Type 2 surge protection plug - VAL-MS 230 ST - 2798844

Technical data

Protective circuit

TOV behavior at U_T	335 V AC (5 s / withstand mode)
	440 V AC (120 min / safe failure mode)
Response time t_A	≤ 25 ns
Max. backup fuse with branch wiring	125 A (gG)

Connection data

Connection method	VALVETRAB plug-in system
-------------------	--------------------------

UL specifications

SPD Type	4CA
Maximum continuous operating voltage MCOV (L-N)	275 V AC
Nom. voltage	230 V AC
Mode of protection	L-N
Power distribution system	1
Nominal frequency	50/60 Hz
Measured limiting voltage MLV (L-N)	1910 V
Nominal discharge current I_n (L-N)	20 kA

Classifications

eCl@ss

eCl@ss 4.0	27140201
eCl@ss 4.1	27130801
eCl@ss 5.0	27130801
eCl@ss 5.1	27130801
eCl@ss 6.0	27130805
eCl@ss 7.0	27130805
eCl@ss 8.0	27130805
eCl@ss 9.0	27130805

ETIM

ETIM 2.0	EC000941
ETIM 3.0	EC000941
ETIM 4.0	EC000941
ETIM 5.0	EC000941

UNSPSC

UNSPSC 6.01	30212010
UNSPSC 7.0901	39121610

Type 2 surge protection plug - VAL-MS 230 ST - 2798844

Classifications

UNSPSC

UNSPSC 11	39121610
UNSPSC 12.01	39121610
UNSPSC 13.2	39121620

Approvals

Approvals

Approvals

IECEE CB Scheme / CSA / UL Recognized / KEMA-KEUR / ÖVE / cUL Recognized / GL / CCA / EAC / EAC / cULus Recognized

Ex Approvals

Approvals submitted

Approval details

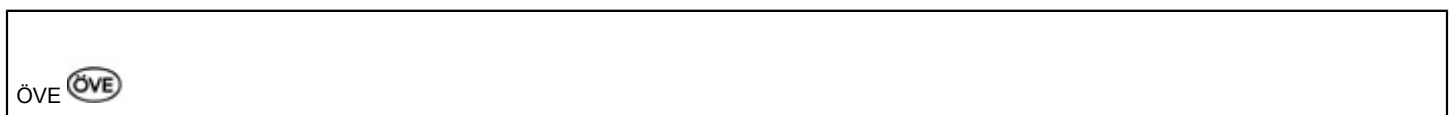

Type 2 surge protection plug - VAL-MS 230 ST - 2798844

Approvals

cUL Recognized 

GL

CCA

EAC

EAC

cULus Recognized 

Drawings

Dimensional drawing

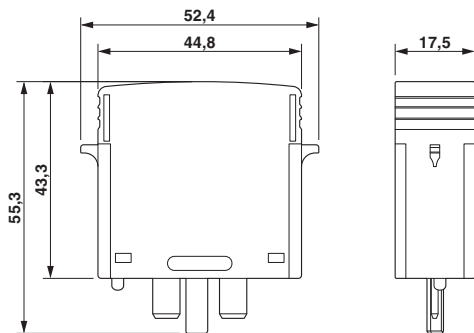

Circuit diagram

