

RJ45C6 R1V 3.2N4N TY

Weidmüller Interface GmbH & Co. KG

Klingenbergstraße 26

D-32758 Detmold

Germany

www.weidmueller.com

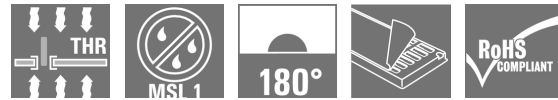

The product range encompasses the following designs:

- 90°, lying (horizontal) and 180°, standing (vertical)
- latch up / latch down
- THT, THR or SMD soldering processes
- Wide range of different design types, also with integrated LEDs and shield contact tabs
- Performance category Cat. 3 to Cat. 6
- Packed either in a tray (TY) or on a roll (tape-on-reel, RL)
- Compatible with modular RJ45 connector according to ANSI / TIA-1096-A and IEC 60603
- Dielectric strength ≥ 1500 V AC RMS (2250 V AC peak value) according to IEEE 802.3
- Dielectric strength ≥ 1500 V AC (peak value) or ≥ 1500 V DC according to IEC 60603

Properties and advantages:

- Extended temperature range of -40°C to $+85^{\circ}\text{C}$ for maximum performance
- Reinforced gold layer ($30\mu\text{m}$) for improved corrosion protection
- At least 0.3mm stand-off ensures a perfect soldering result

General ordering data

Version	PCB plug-in connector, RJ45 jacks, THT/THR solder connection, 180°, Number of poles: 8
Order No.	2634590000
Type	RJ45C6 R1V 3.2N4N TY
GTIN (EAN)	4050118651270
Qty.	140 pc(s).

RJ45C6 R1V 3.2N4N TY

Weidmüller Interface GmbH & Co. KG

Klingenbergstraße 26

D-32758 Detmold

Germany

www.weidmueller.com

Technical data

Dimensions and weights

Net weight	7.475 g
------------	---------

System specifications

Mounting onto the PCB	THT/THR solder connection	Number of poles	8
Outgoing elbow	180°	Plugging cycles	750
Product family	OMNIMATE Data - RJ45 modular jack	Protection degree	IP20
Shield surface	nickel-plated	Soldering process	Reflow soldering, Manual soldering, Wave soldering

Electrical properties

Dielectric strength, contact / contact	1000 V DC	Dielectric strength, contact / shield	1500 V DC
--	-----------	---------------------------------------	-----------

Packing

VPE length	0.315 m	VPE width	0.195 m
VPE height	0.065 m		

Classifications

ETIM 6.0	EC002637	ETIM 7.0	EC002637
ECLASS 9.0	27-44-04-02	ECLASS 9.1	27-44-04-02
ECLASS 10.0	27-44-04-02	ECLASS 11.0	27-46-02-01

Approvals

ROHS	Conform
------	---------

Downloads

Brochure/Catalogue	Catalogues in PDF-format
--------------------	--

RJ45C6 R1V 3.2N4N TY

Weidmüller Interface GmbH & Co. KG
 Klingenbergstraße 26
 D-32758 Detmold
 Germany

www.weidmueller.com

Drawings

Dimensioned drawing

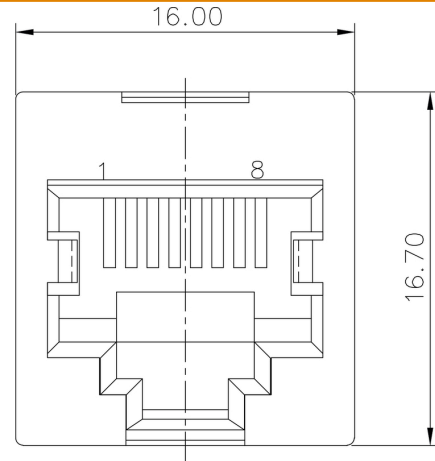
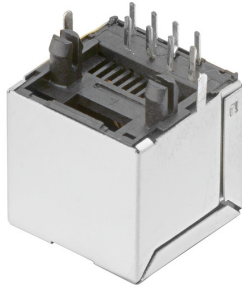

Dimensioned drawing

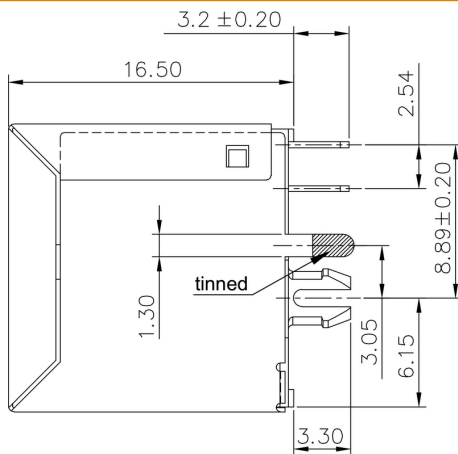

Dimensioned drawing

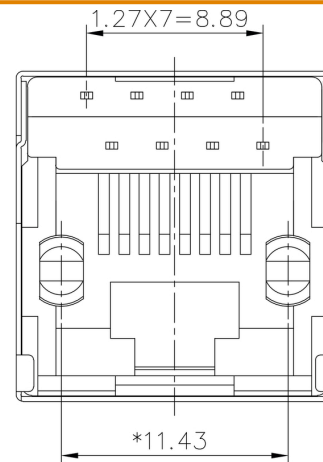

PCB design

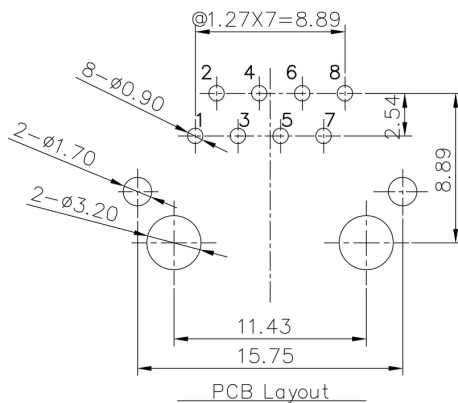

RJ45C6 R1V 3.2N4N TY

Weidmüller Interface GmbH & Co. KG
 Klingenbergstraße 26
 D-32758 Detmold
 Germany

www.weidmueller.com

Drawings

Code	Value	Description
RJ45	G1	RJ45G1
R1	R	R1R
U	U	U
3.2	3.2	3.2
E	E	E
4	4	4
GY/GY	GY/GY	GY/GY
TY	TY	TY
RJ45G1 R1U 3.2E4GY/GY TY		
Packaging	TY	Tray in box (manual assembly)
	RL	Tape on Reel (automated assembly)
LED	Y/G	Yellow/Green
	G/Y	Green/Yellow (standard)
	GY/GY	Green-Yellow/Green-Yellow
	O/G	Orange/Green
	R/O	Red/Orange
 (further combinations possible)
	N	without LED
Contact surface thickness	4	1 = 3µ", 2 = 6µ", 3 = 15µ", 4 = 30µ", 5 = 50µ"
EMI tabs (ground fingers)	E	E = with EMI tabs
	N	N = without EMI tabs
Solder Pin length	3.2	3.2 mm
	1.6	1.6 mm
	D	SMD
Direction, latch style	U	Horizontal (90°, side entry), latch up
	D	Horizontal (90°, side entry), latch down
	V	Vertical (180°, top entry)
	Y	Diagonal (45°), latch up
Number of Ports	1	1 Port
	12; 14; ...	multi ports side by side, Multiport
	21; 41; ...	multi ports about each other, Multilevel
Assembly on PCB	R	Through Hole Reflow - THR
	S	Soldering process: Wave or Reflow soldering
	S	Surface Mount Technology - SMT
	T	Soldering process: Reflow soldering
	T	Through Hole Technology - THT
	T	Soldering process: Wave
Performance Category	C5	Category 5
	C6	Category 6
	C6A	Category 6A
	C5e	Category 5e
	M	10/100 Mbit
	G1	10/100/1000 Mbit
	G10	10 Gbit
	U	Unshielded
	MP	10/100 Mbit with POE
	MP+	10/100 Mbit with POE+

Legend

Recommended wave soldering profiles

Weidmüller Interface GmbH & Co. KG
 Klingenbergstraße 16
 D-32758 Detmold
 Germany
 Fon: +49 5231 14-0
 Fax: +49 5231 14-292083
 www.weidmueller.com

Single Wave:



Double Wave:



Wave soldering profiles

Wired connection elements should be processed in accordance with the DIN EN 61760-1 standard. We have included two recommendations for practical wave soldering profiles, with which Weidmüller PCB terminals and connectors are qualified.

When choosing a suitable profile for your application, the following factors also need to be considered:

- PCB thickness
- Proportion of Cu in the layers
- Single/double-sided assembly
- Product range
- Heating and cooling rates

The single and double wave profiles each indicate the recommended operating range, including the maximum soldering temperature of 260°C. In practice, the maximum soldering temperature is quite often well below the above maximum profile.

Recommended reflow soldering profile

Weidmüller Interface GmbH & Co. KG
 Klingenbergstraße 16
 D-32758 Detmold
 Germany
 Fon: +49 5231 14-0
 Fax: +49 5231 14-292083
 www.weidmueller.com



Reflow soldering profile

The perfect soldering profile for SMT Surface Mount Technology is one the most exiting question in SMT production. But there are more than one correct answer: The diagram of temperature-on-time is related to processing features of solder paste and to maximum load of components.

We have to consider the following parameters:

- Time for pre heating
- Maximum temperature
- Time above melting point
- Time for cooling
- Maximum heating rate
- Maximum cooling rate

We recommend a typical solder profile with associated process limits. With preheating components and board are prepared smoothly for the solder phase. Heating rate is typically $\leq +3\text{K/s}$. In parallel the solder paste is ‚activated‘. The time above melting point of 217°C the paste gets liquid and components and boards begin to connect. The maximum temperature of 245°C to 254°C should stay between 10 and 40 seconds. In the cooling phase at $\geq -6\text{K/s}$ solder is cured. Board and components cool down while avoiding cold cracks.