

LOC	DIST	REVISIONS			
P	LTN	DESCRIPTION	DATE	DMN	APVD
B		REVISED PER ECO-18-006791	07MAY2018	TX	SH
C		REVISED PER ECO-18-011602	24JUL2018	TX	SH
D		REVISED PER ECR-19-012797	27AUG2019	RM	SH

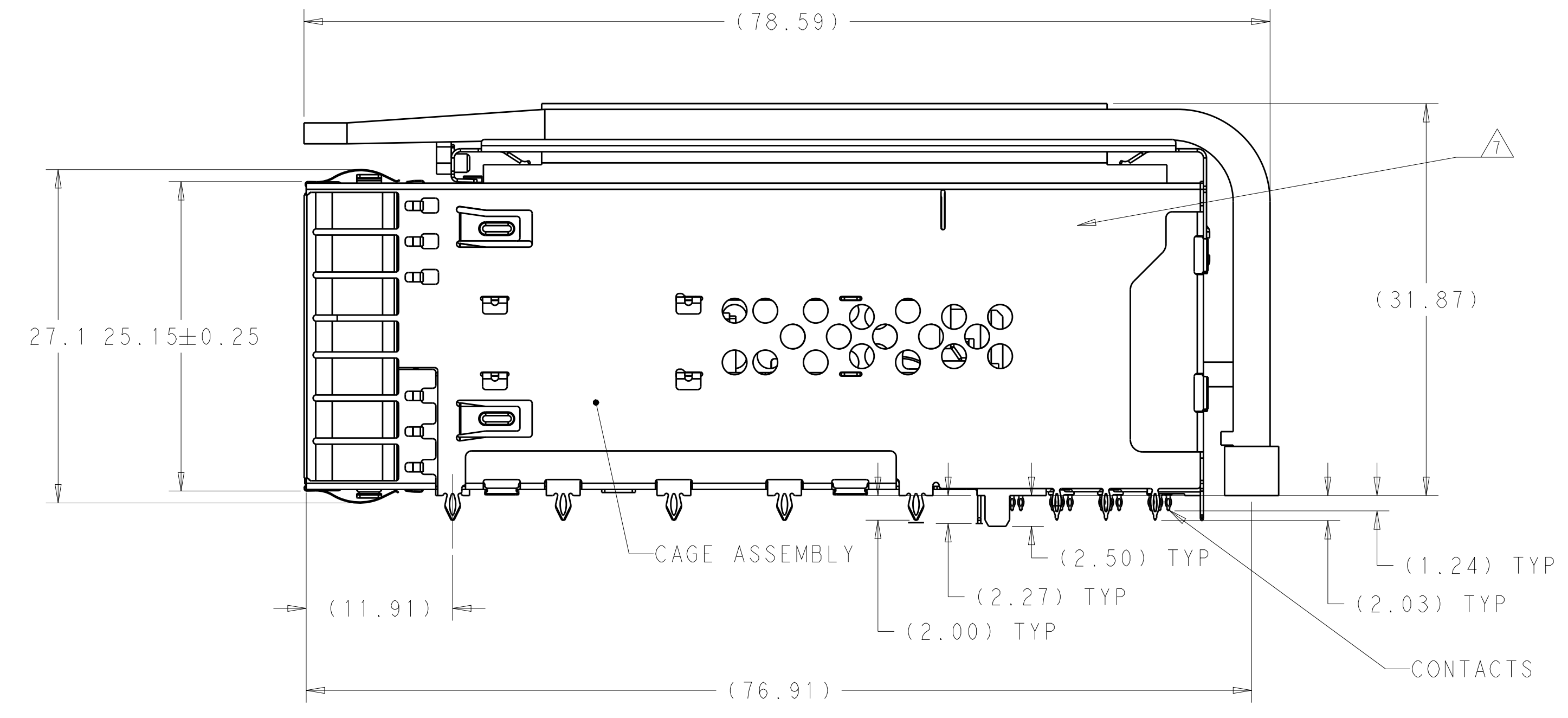

- MATERIALS:
 CAGE ASSEMBLY- NICKEL SILVER ALLOY PER ASTM B 122.
 EMI SPRING- COPPER ALLOY, NICKEL PLATED.
 HOUSING- POLYESTER LCP WITH 94 V-0
 CHICKLET- POLYESTER LCP WITH 94 V-0
 CONTACT- COPPER ALLOY.
 LIGHTPIPE- POLYCARBONATE
 HEAT SINK- ALUMINUM
 CLIP- STAINLESS STEEL
- CONTACT FINISH: 0.76µm GOLD ON MATING AREA, 0.7-1.5µm.MATT TIN ON COMPLIANT AREA, ALL OVER 1.27µm NICKEL.
- DATUM AND BASIC DIMENSION ESTABLISHED BY CUSTOMER.
- MINIMUM PCB THICKNESS OF 1.57.
- THE ENTIRE AREA OF THE CONNECTOR FOOTPRINT, INDICATED BY THE DASHED LINE, TO BE CONSIDERED THE KEEPOUT AREA FOR COMPONENTS.
- CROSS-HATCHED AREAS REPRESENT ZONES ON THE PCB THAT COME IN CONTACT WITH OR BE IN CLOSE PROXIMITY TO THE PLASTIC HOUSING OR THE CONNECTOR CAGE. INDICATED AREAS TO BE CONSIDERED TRACE FREE.
- PART NUMBER AND DATE CODE MADE IN APPROXIMATE AREA SHOWN.
- HATCHED AREA IS PLACEMENT ZONE FOR LED. LED SHOULD BE CENTERED WITHIN ZONE. RECOMMEND 0805 PACKAGE.

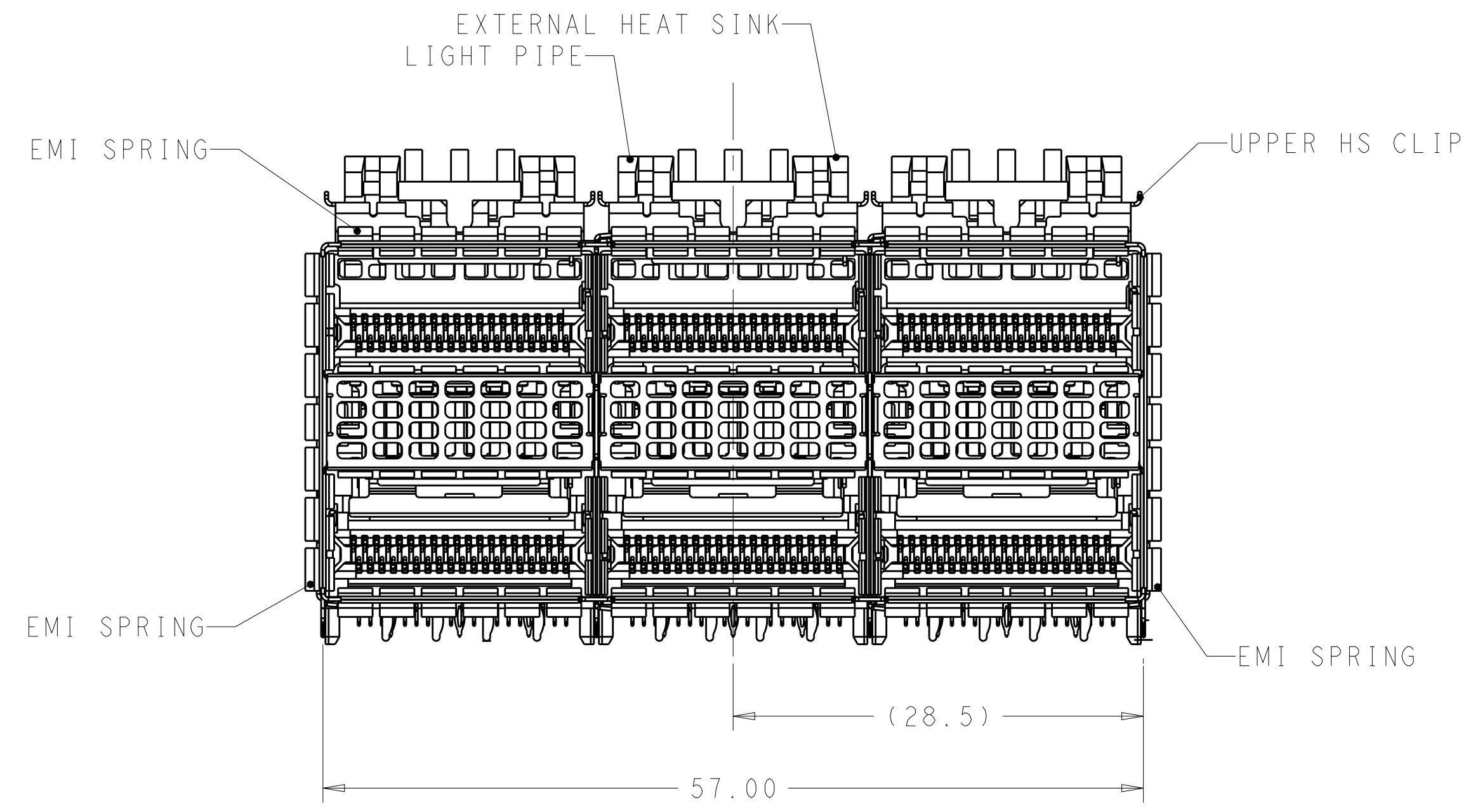
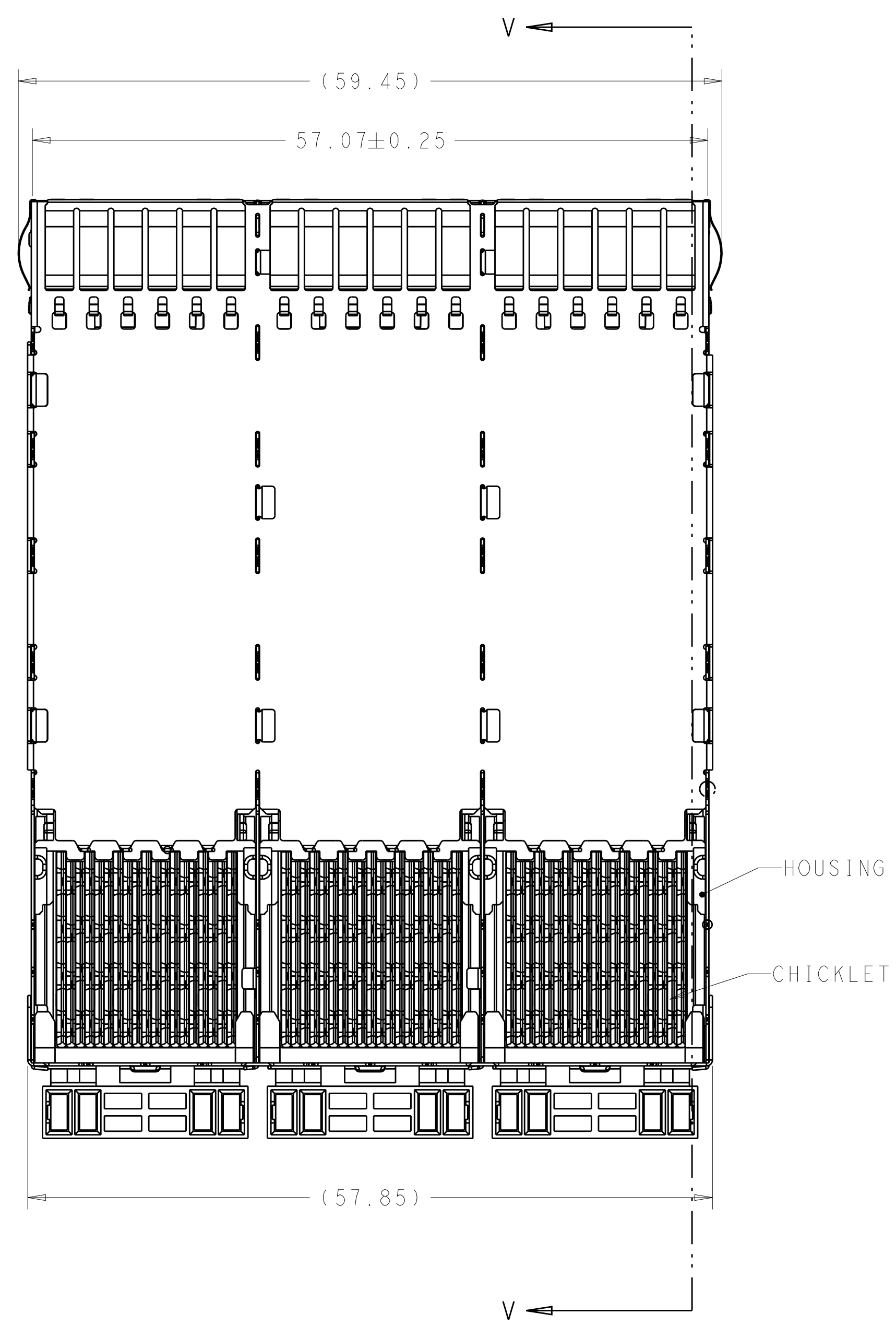

CONTACT FINISH	DESCRIPTION	PART NUMBER
△2	WITHOUT UPPER HS & LP	2-2299924-4
△2	WITH HS & WITH LP	1-2299924-6
△2	WITH HS & WITHOUT LP	1-2299924-3
△2	WITH HS & WITH LP	1-2299924-1
△2	WITH HS & WITH LP	1-2299924-0
△2	WITH HS & WITH LP	2299924-8
△2	WITH HS & WITH LP	2299924-7
△2	WITH HS & WITH LP	2299924-6
△2	WITH HS & WITH LP	2299924-5
△2	WITHOUT UPPER HS OR LP	2299924-4
△2	WITH HS & WITHOUT LP	2299924-3
△2	WITH HS & WITHOUT LP	2299924-2
△2	WITH HS & WITH LP	2299924-1

THIS DRAWING IS A CONTROLLED DOCUMENT. DWG: ARTHUR JLN 20JAN2016
 CHK: SEAN HAN 20JAN2016
 APVD: SEAN HAN 20JAN2016

STE TE Connectivity

NAME: CAGE AND CONNECTOR ASSEMBLY WITH EMI SPRING FINGERS, THRU BEZEL, 2X3 ZOSFP+ STACKED WITH HS

SIZE: A1 CAGE CODE: 2299924 DRAWING NO: 100779

SCALE: 1:1 SHEET 1 OF 9 REV D

LOC	DIST	REVISIONS					
GP	00	P	LYR	DESCRIPTION	DATE	OWN	APVD
		-		SEE SHEET 1			

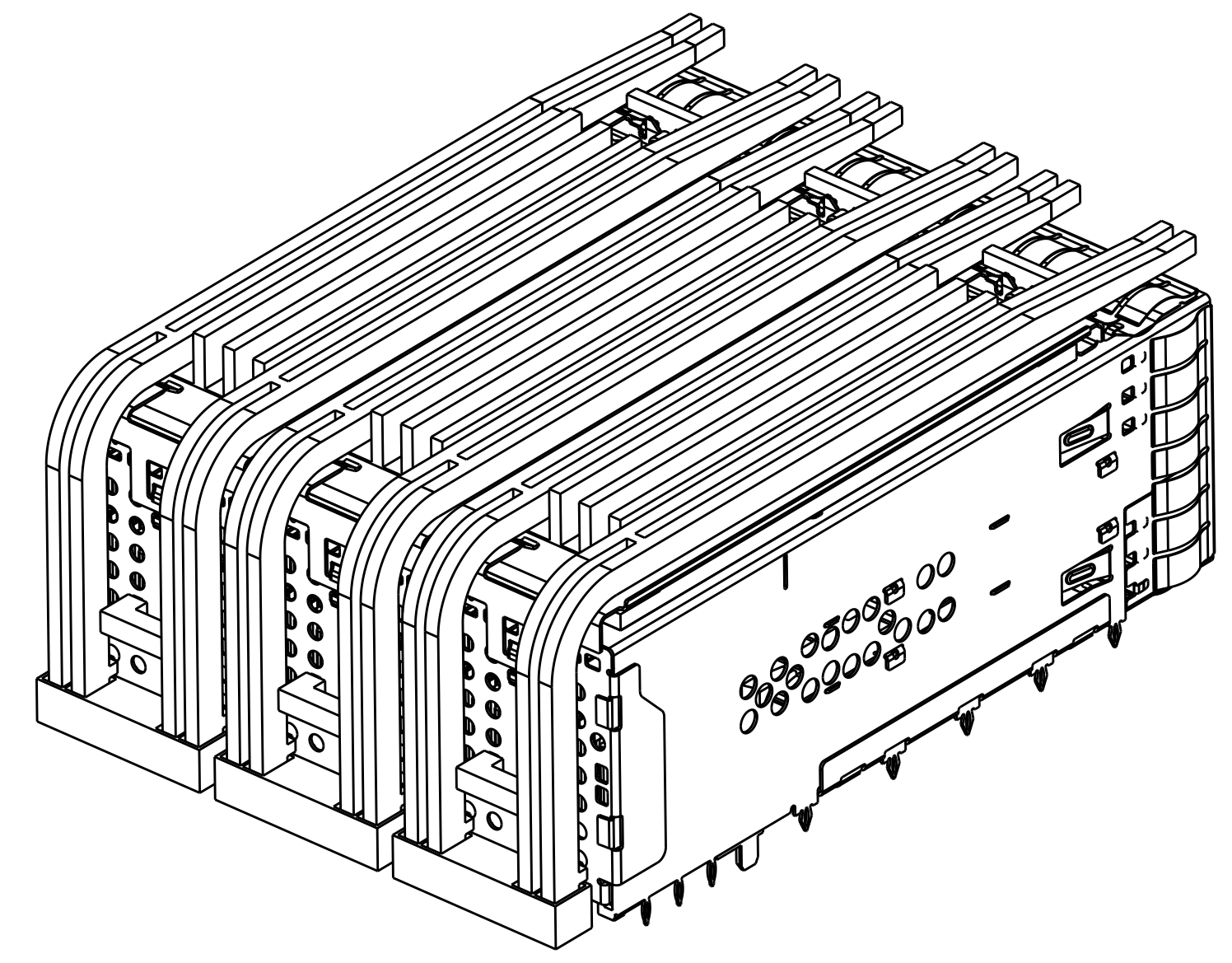

2299924-1
 1-2299924-1
 AS SHOWN
 SCALE 2:1

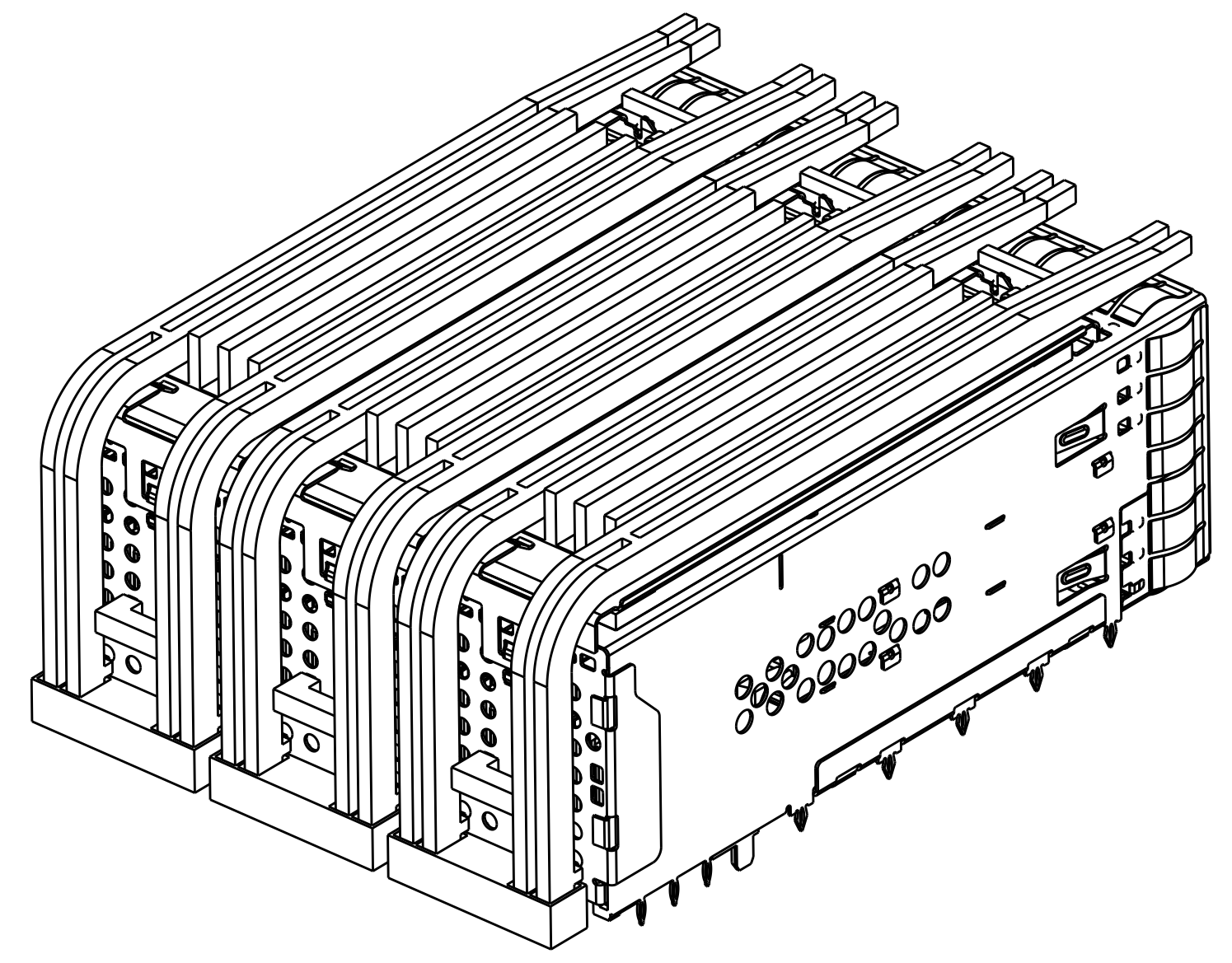

2299924-5 AS SHOWN
 HAS THE SAME APPEARANCE WITH 2299924-1
 BUT DIFFERENT INTERNAL HEAT SINK
 SCALE 2:1

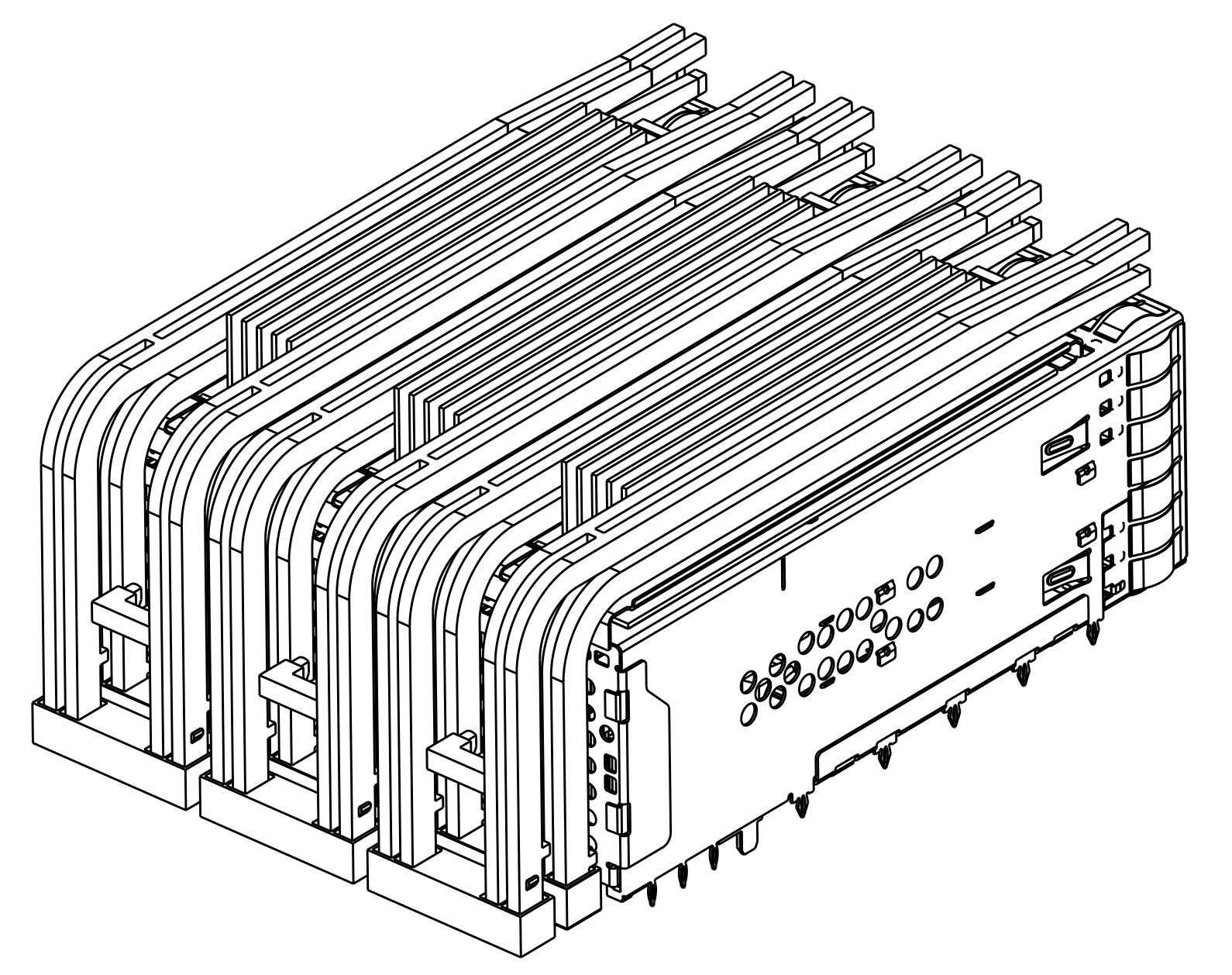

2299924-7
 SCALE 2:1

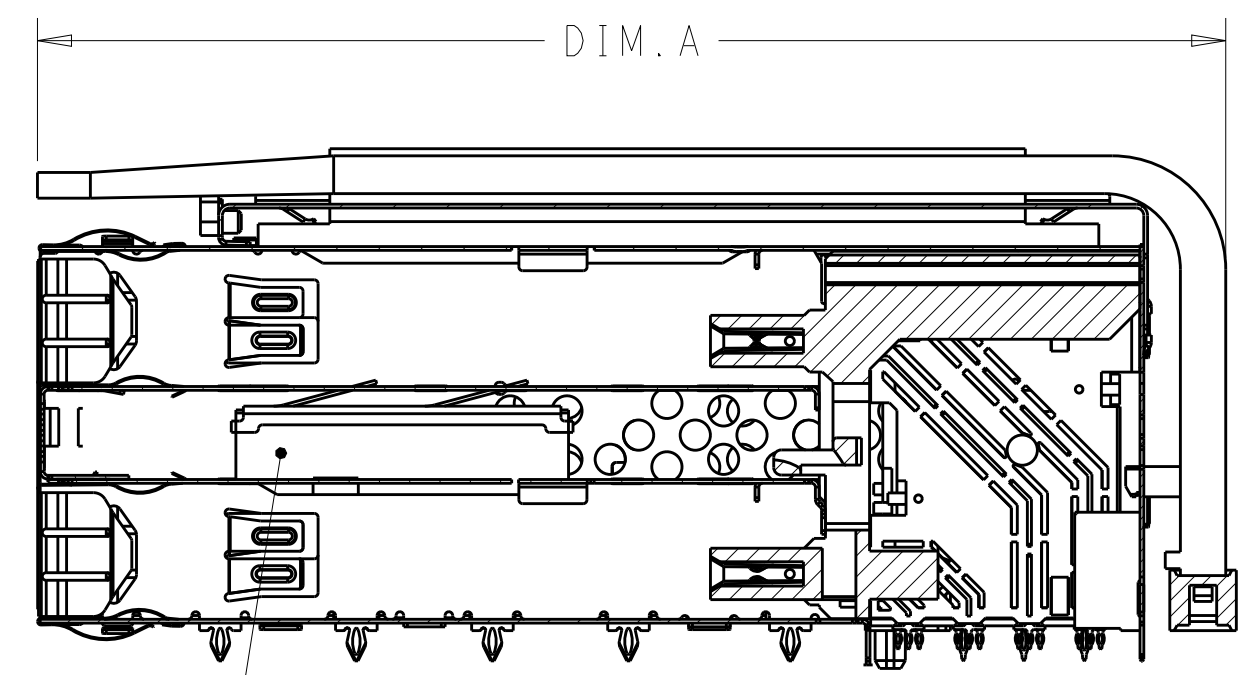

SHORT INTERNAL HEAT SINK

2299924-1
 1-2299924-1
 SECTION VIEW
 SECTION V-V
 SCALE 2:1

75.3	1-2299924-1
78.59	2299924-1
DIM.A	PART NUMBER

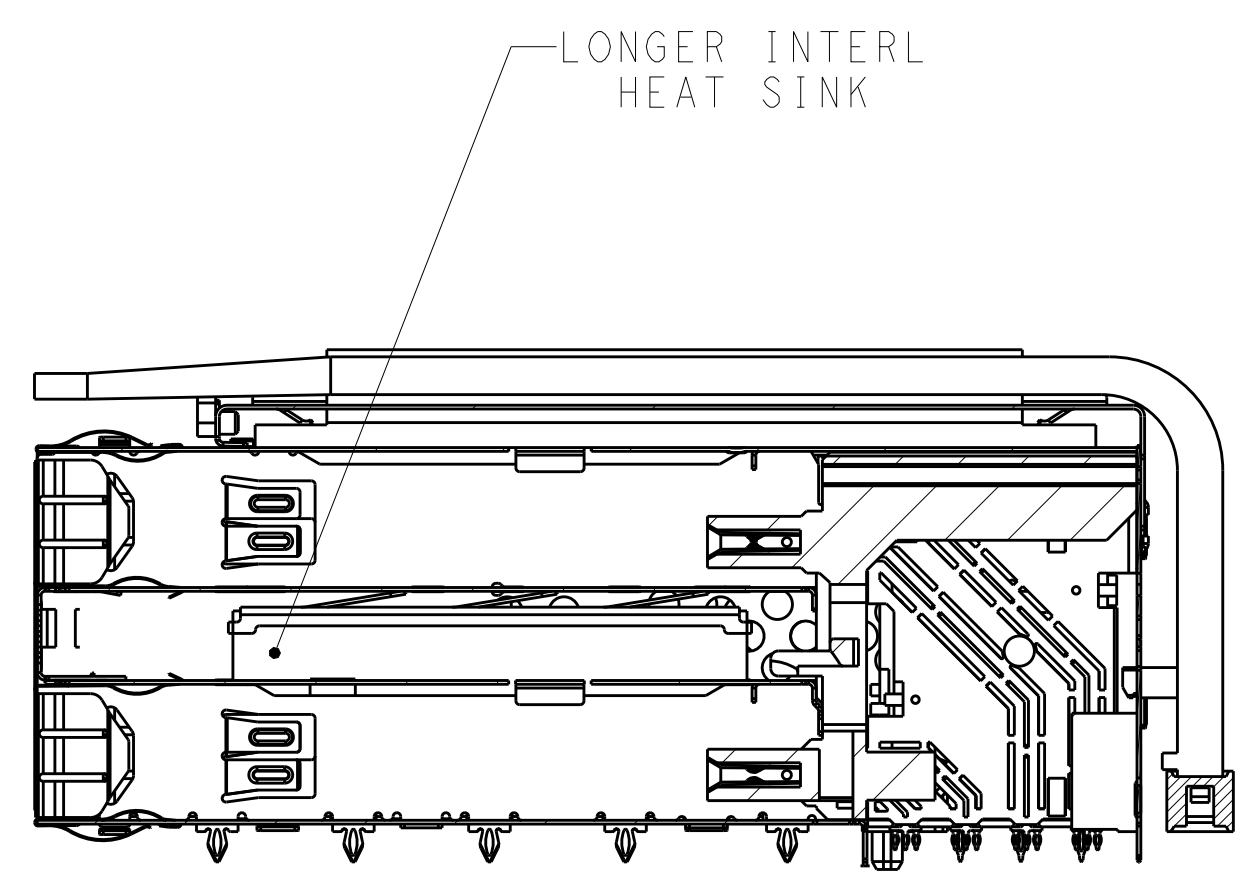

LONGER INTERL HEAT SINK

2299924-5 SECTION VIEW
 THE SAME AS 2299924-1 EXCEPT THE LONGER INTER HEAT SINK
 SECTION V-V
 SCALE 2:1

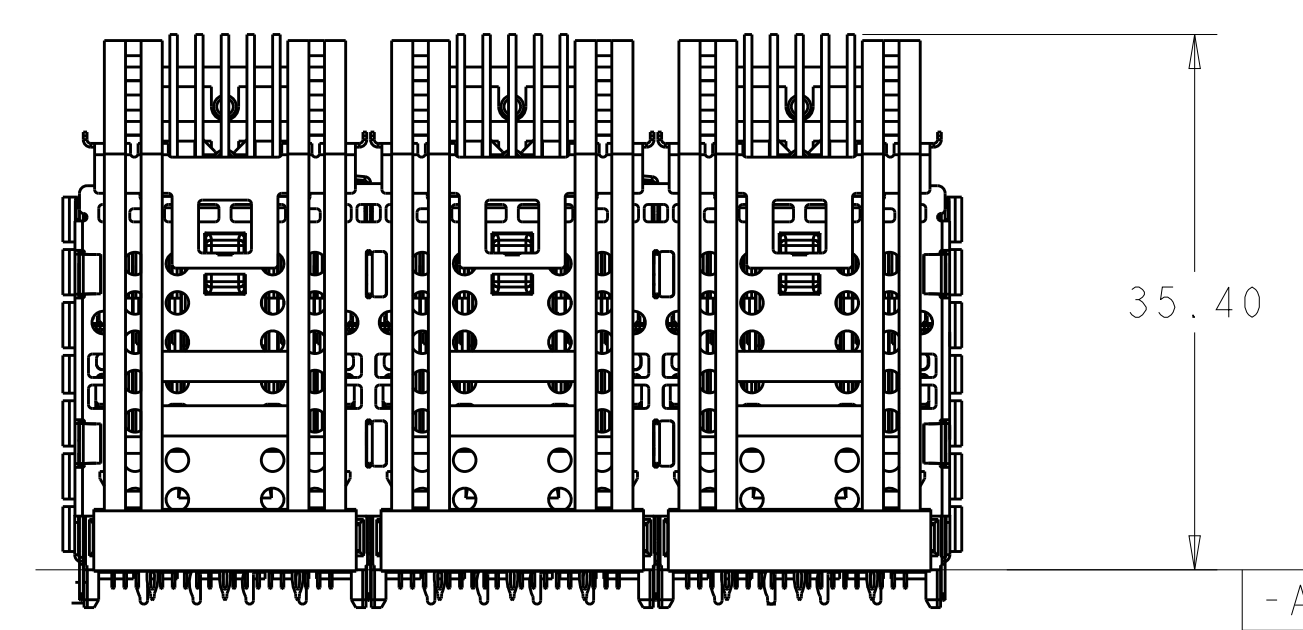

2299924-7
 SCALE 2:1

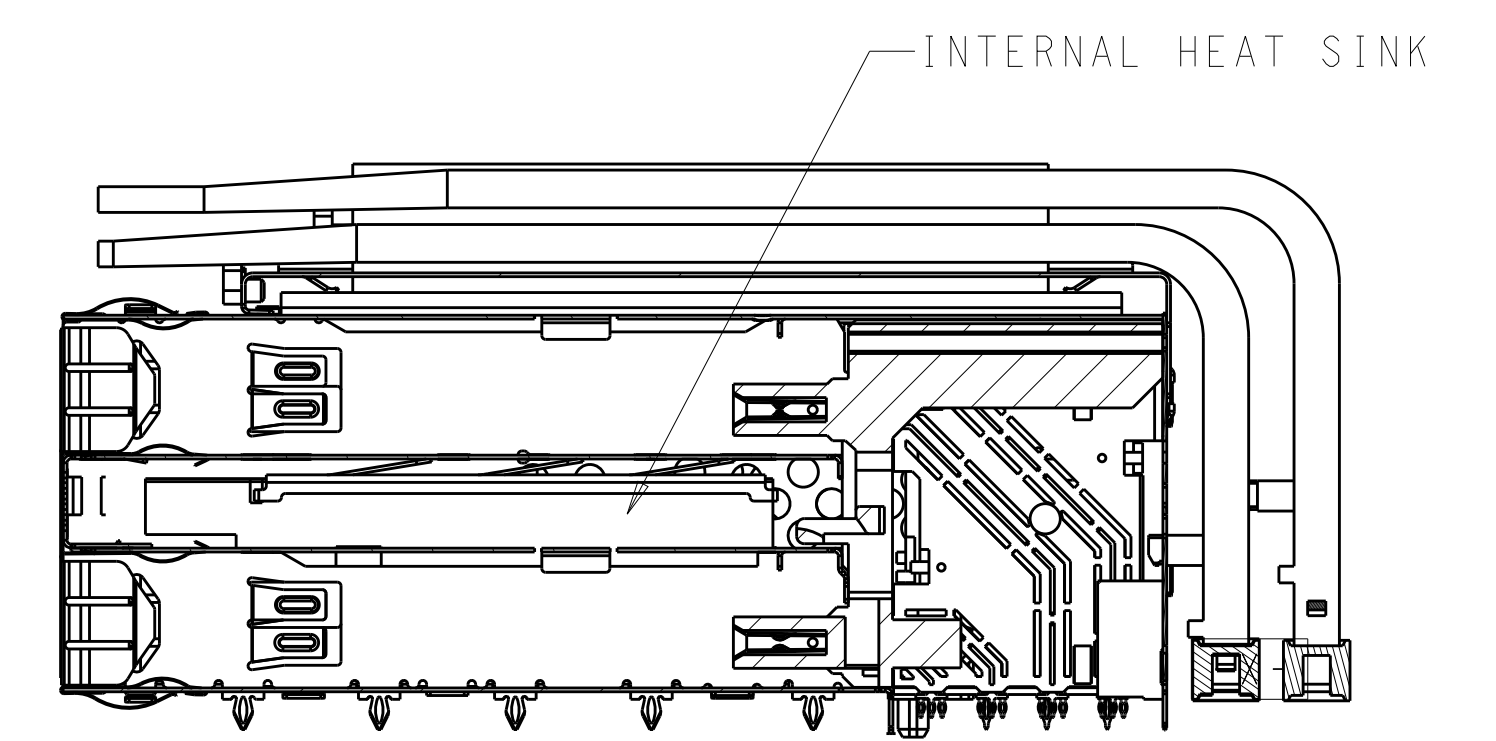

INTERNAL HEAT SINK

2299924-7
 SECTION V-V
 SCALE 2:1

THIS DRAWING IS A CONTROLLED DOCUMENT. DWN: ARTHUR JLN 20JAN2016
 CHK: SEAN HAN 20JAN2016
 APVD: SEAN HAN 20JAN2016

STE TE Connectivity

NAME: CAGE AND CONNECTOR ASSEMBLY WITH EMI SPRING FINGERS, THRU BEZEL, 2X3 ZOSFP+ STACKED WITH HS

PRODUCT SPEC: -
 APPLICATION SPEC: -
 SIZE: A1 CAGE CODE: 00779 DRAWING NO: 2299924 RESTRICTED TO
 WEIGHT: -
 MATERIAL: SEE NOTE 1 FINISH: SEE NOTE 2 CUSTOMER DRAWING

SCALE: 1:1 SHEET 2 OF 9 REV D

LOC	DIST	REVISIONS			
P	LYR	DESCRIPTION	DATE	OWN	APVD
-	-	SEE SHEET 1	-	-	-

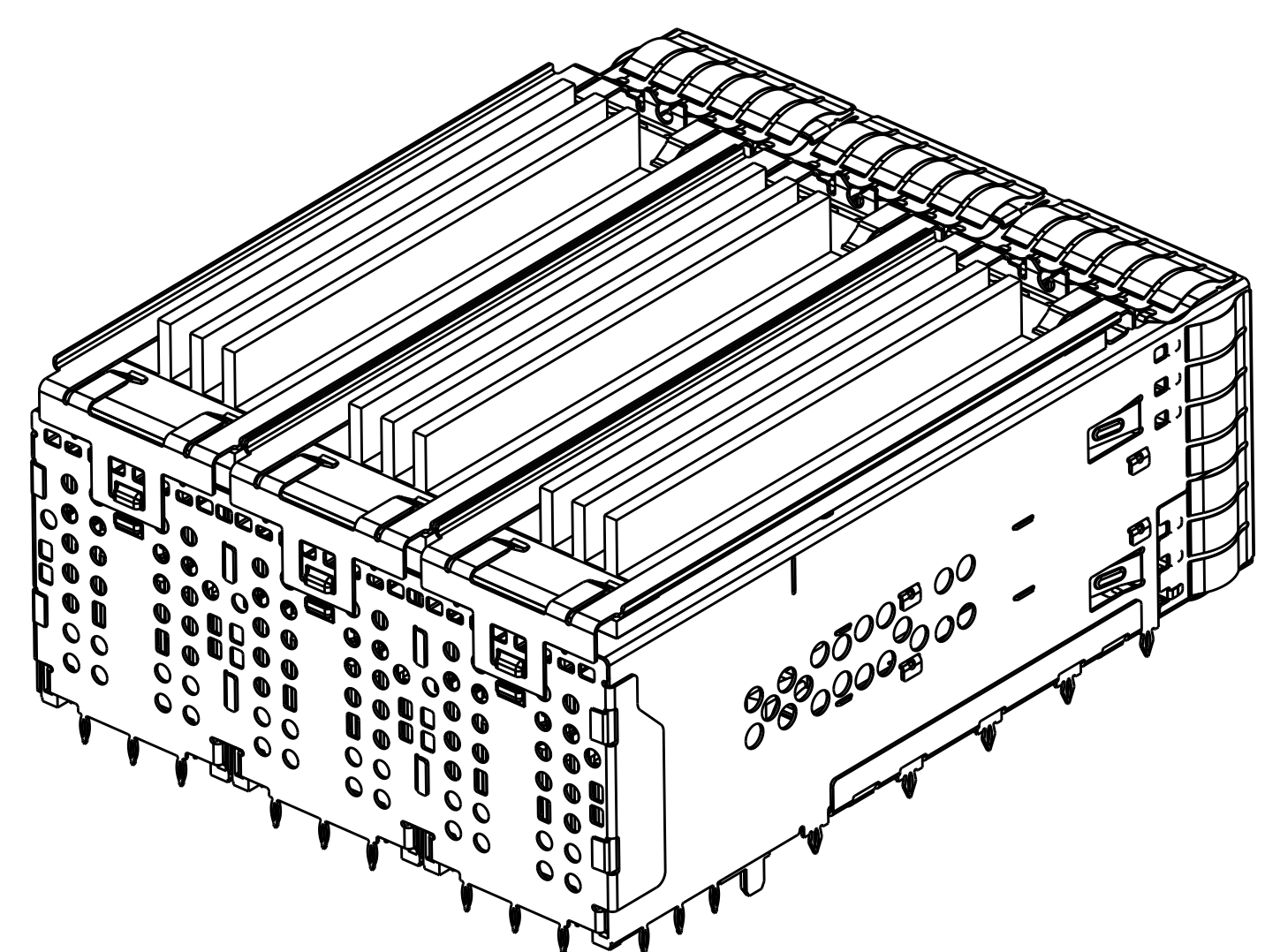

2299924-2 AS SHOWN
 THE SAME AS 2299924-5 EXCEPT
 W/O LIGHT PIPE AND ORGANIZER
 SCALE 2:1

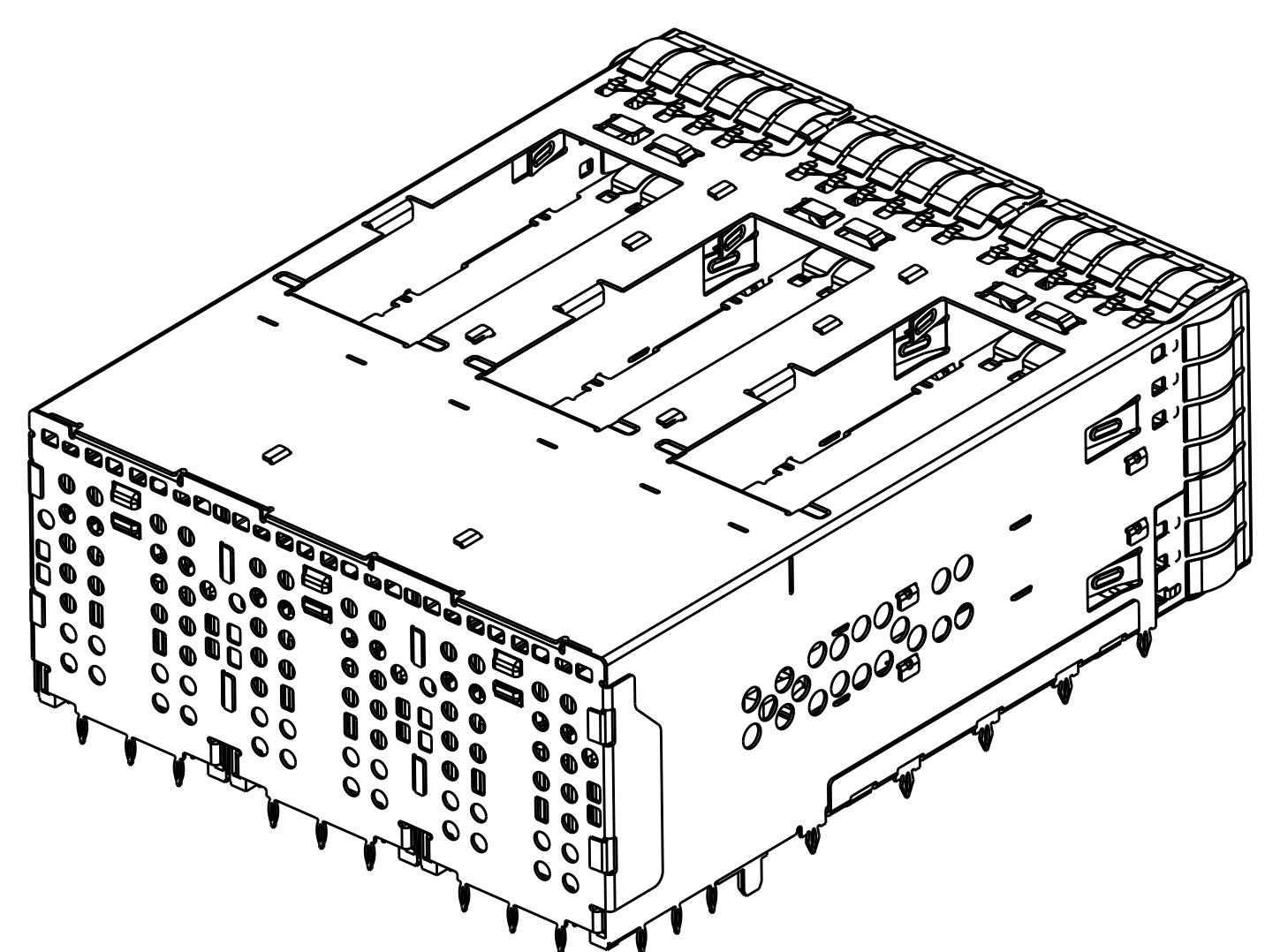

2299924-4 AS SHOWN
 THE SAME AS 2299924-2 EXCEPT
 WITHOUT EXTERNAL HEAT SINK AND LP
 SCALE 2:1

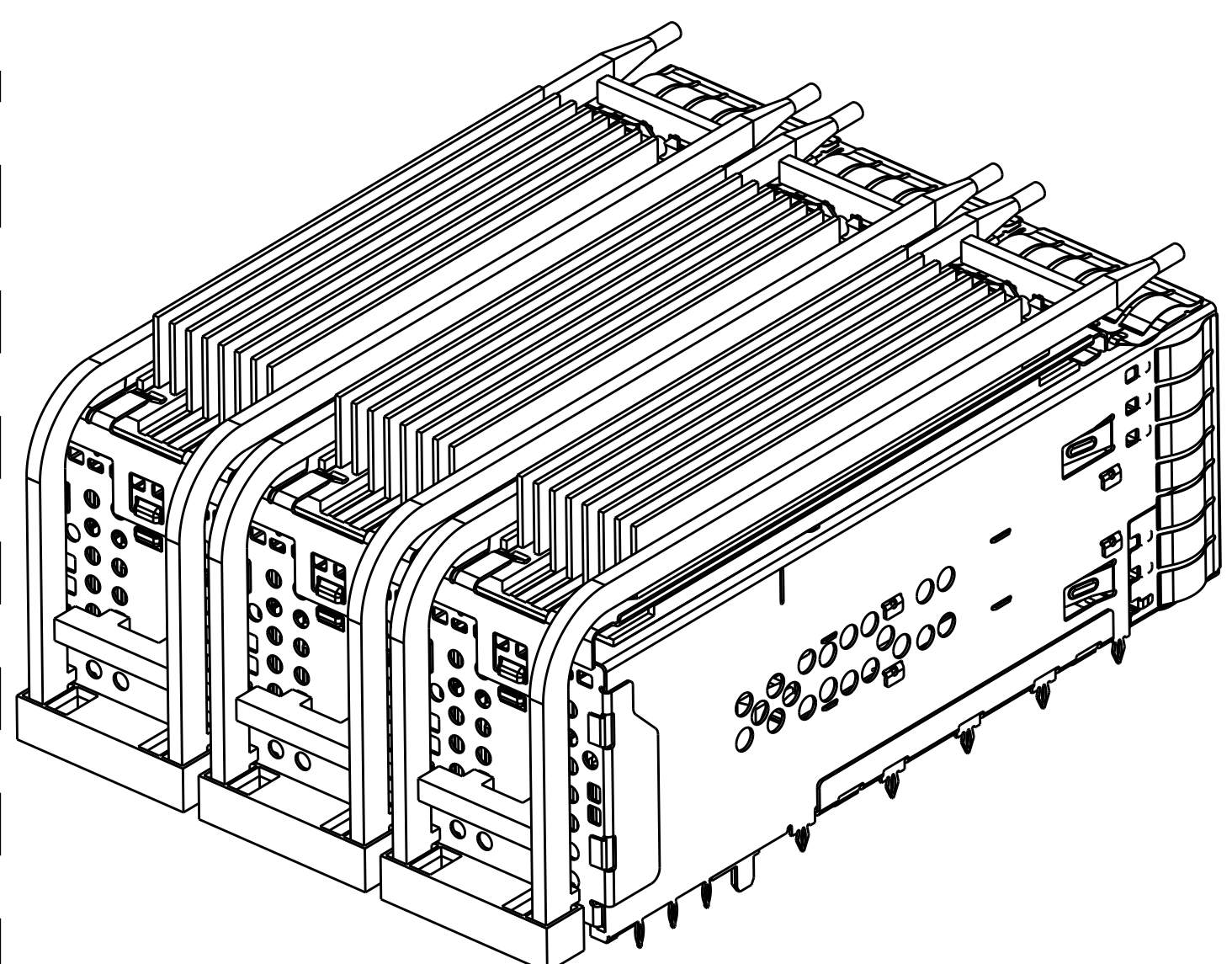

2299924-6
 SCALE 2:1

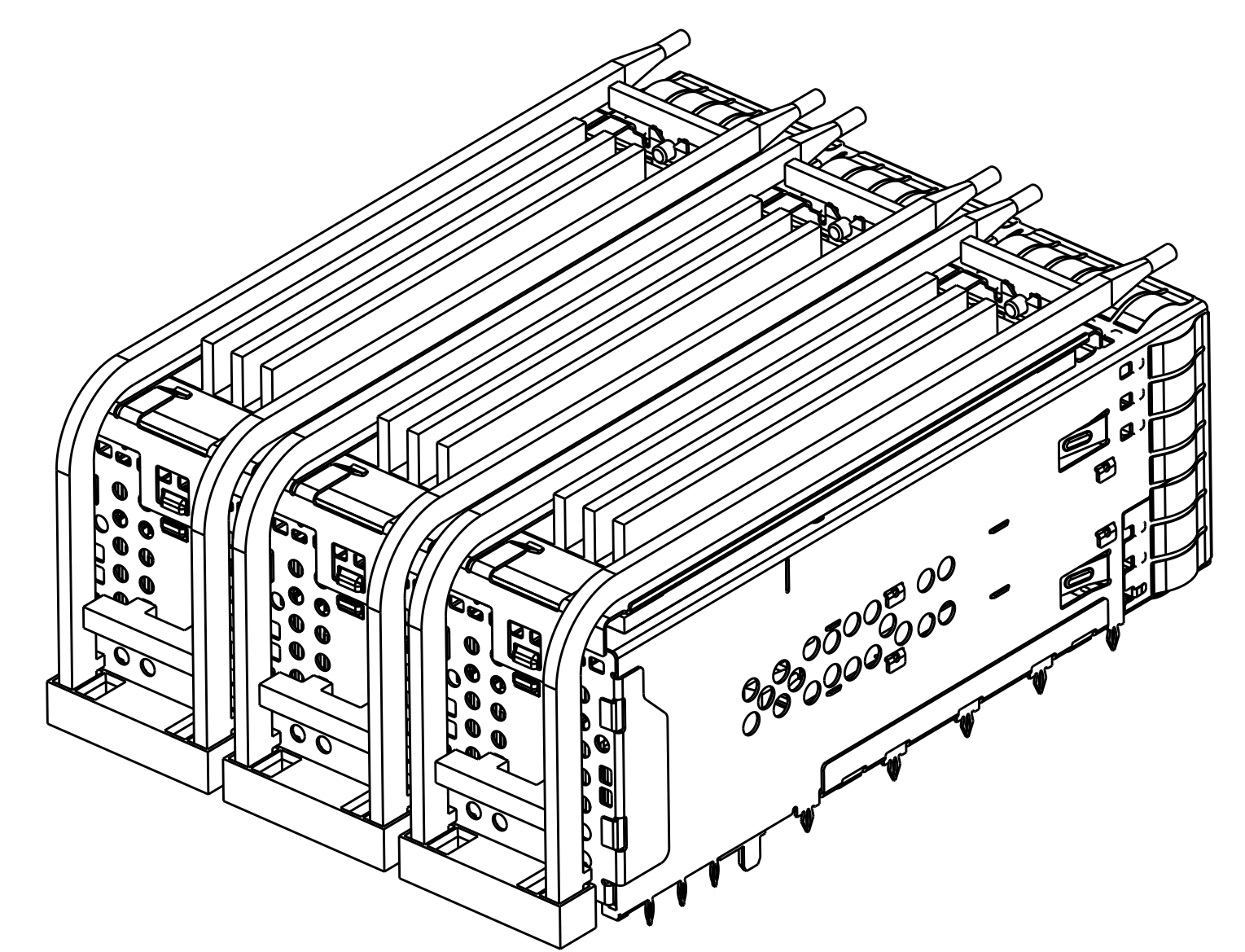

1-2299924-0
 SCALE 2:1

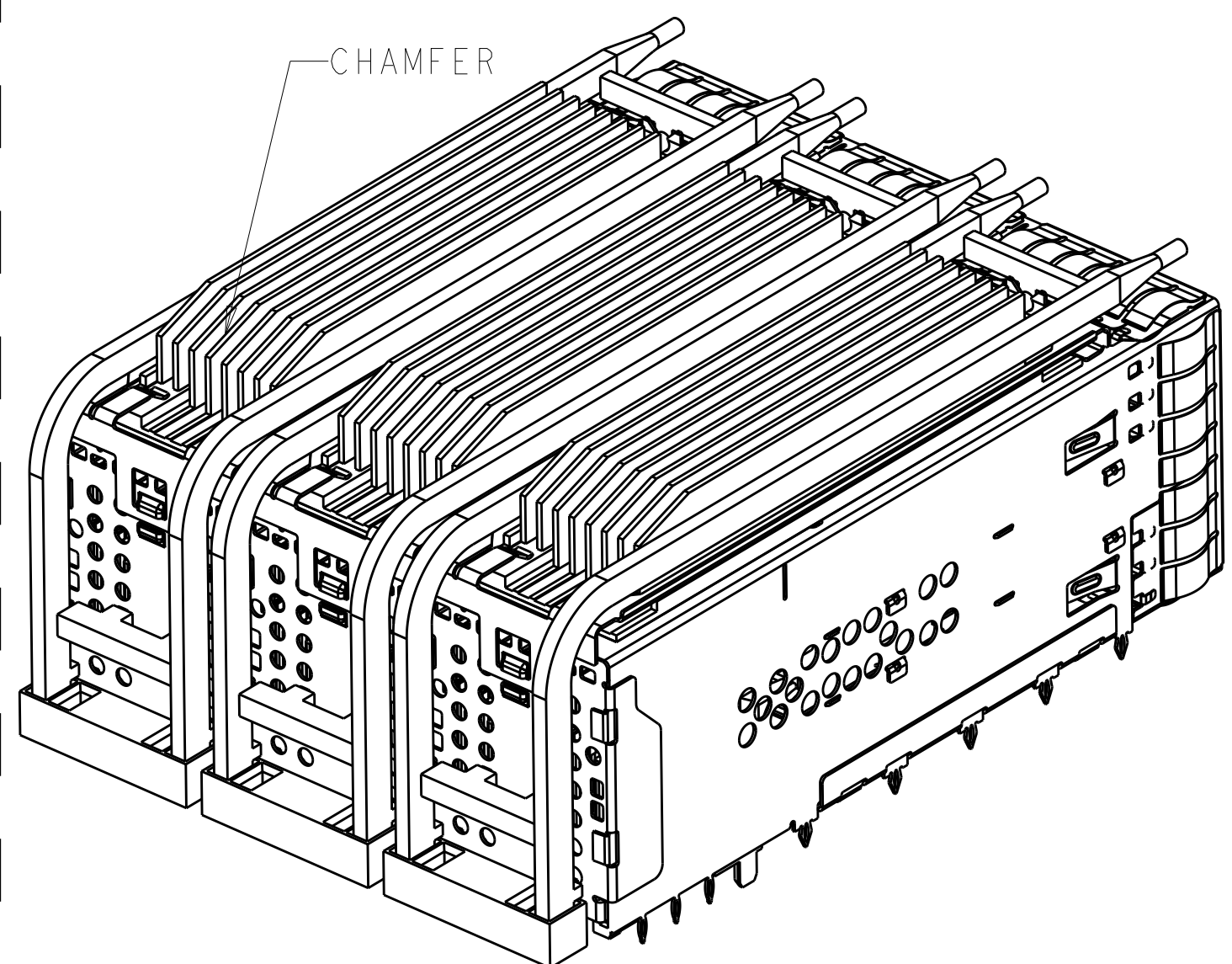

1-2299924-6
 SCALE 2:1

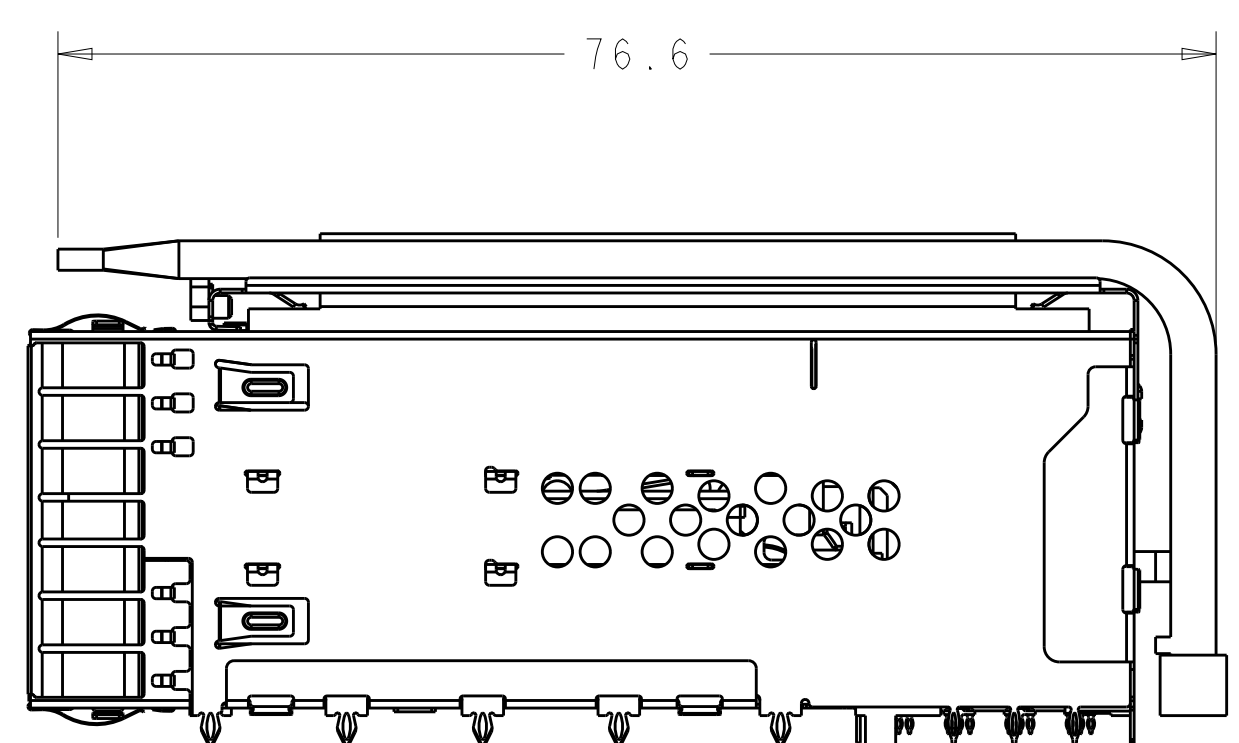

SCALE 2:1

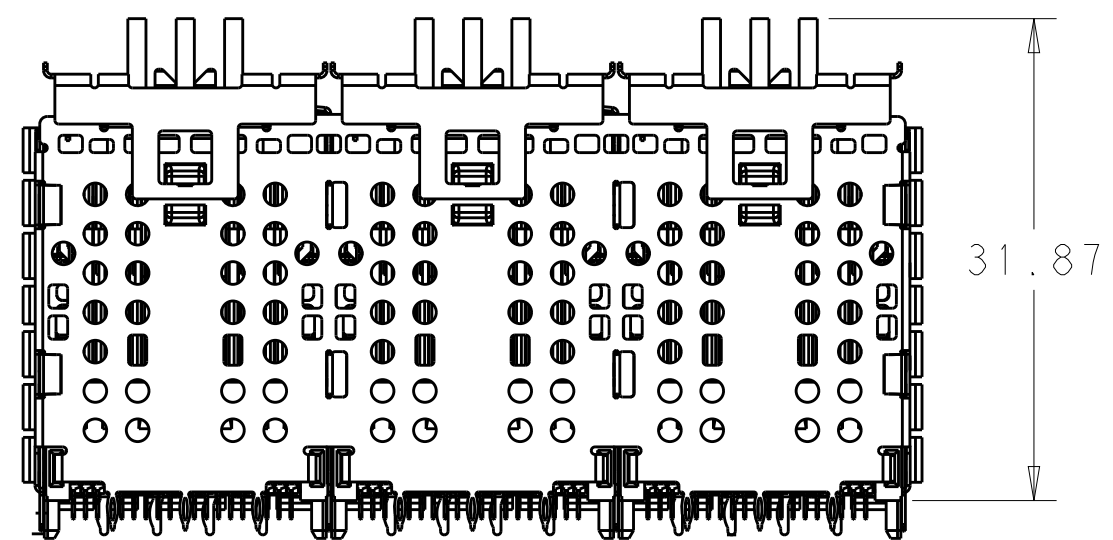

2299924-2
 SCALE 2:1

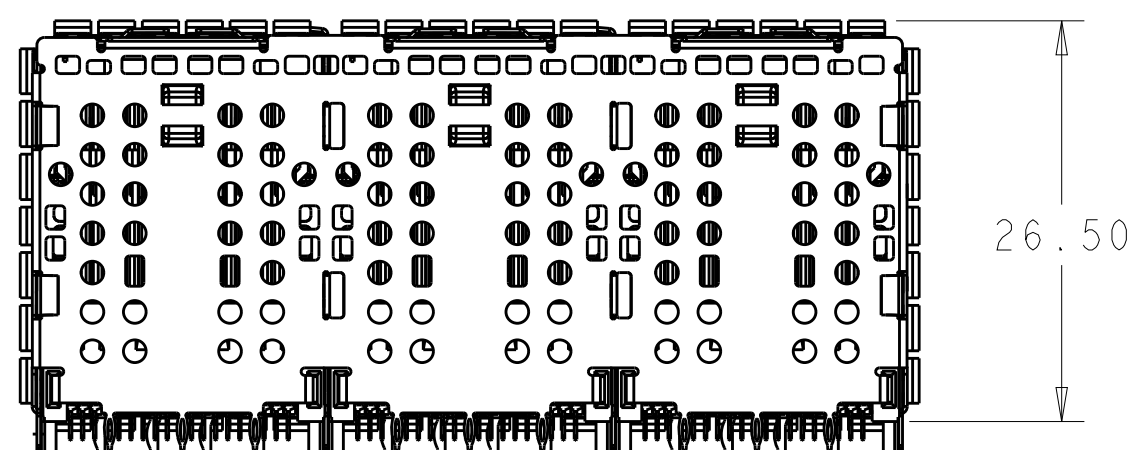

2299924-4
 SCALE 2:1

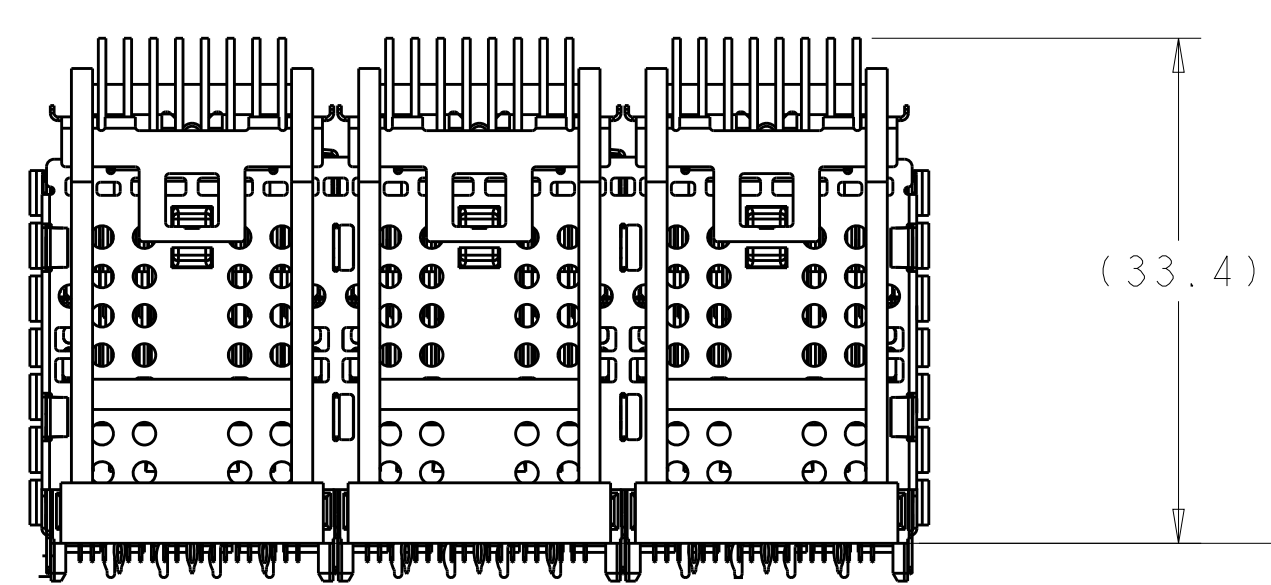

2299924-6
 1-2299924-6
 SCALE 2:1

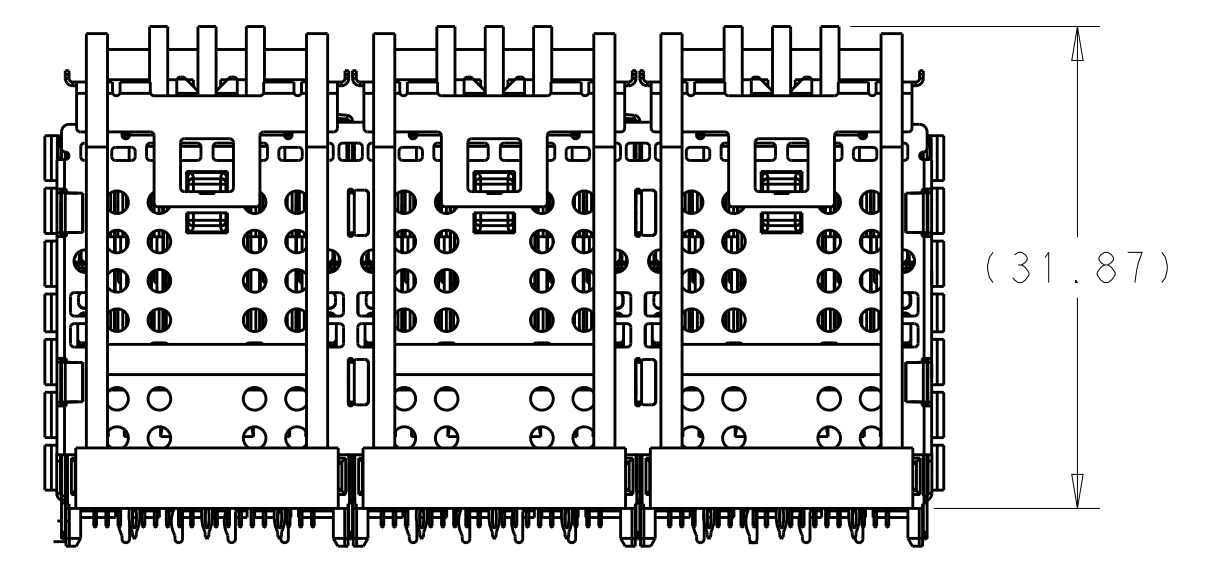

SCALE 2:1

THIS DRAWING IS A CONTROLLED DOCUMENT.		OWN: ARTHUR JIN 20JAN2016	TE Connectivity
DIMENSIONS: mm		CHK: SEAN HAN 20JAN2016	
TOLERANCES UNLESS OTHERWISE SPECIFIED:		APVD: SEAN HAN 20JAN2016	NAME: CAGE AND CONNECTOR ASSEMBLY WITH EMI SPRING FINGERS, THRU BEZEL, 2X3 ZOSFP+ STACKED WITH HS
0 PLC ± 1 PLC ±0.25 2 PLC ±0.15 3 PLC ± 4 PLC ± ANGLES ±		PRODUCT SPEC	
MATERIAL: SEE NOTE 1	FINISH: SEE NOTE 2	WEIGHT: -	RESTRICTED TO: -
CUSTOMER DRAWING		SIZE: A1 00779	SCALE: 1:1
		CAGE CODE: C=2299924	SHEET 3 OF 9

LOC	DIST	REVISIONS					
GP	00	P	LTN	DESCRIPTION	DATE	DMN	APVD
-	-	-	-	SEE SHEET 1	-	-	-

2299924-3 AS SHOWN, KIT PACKAGE

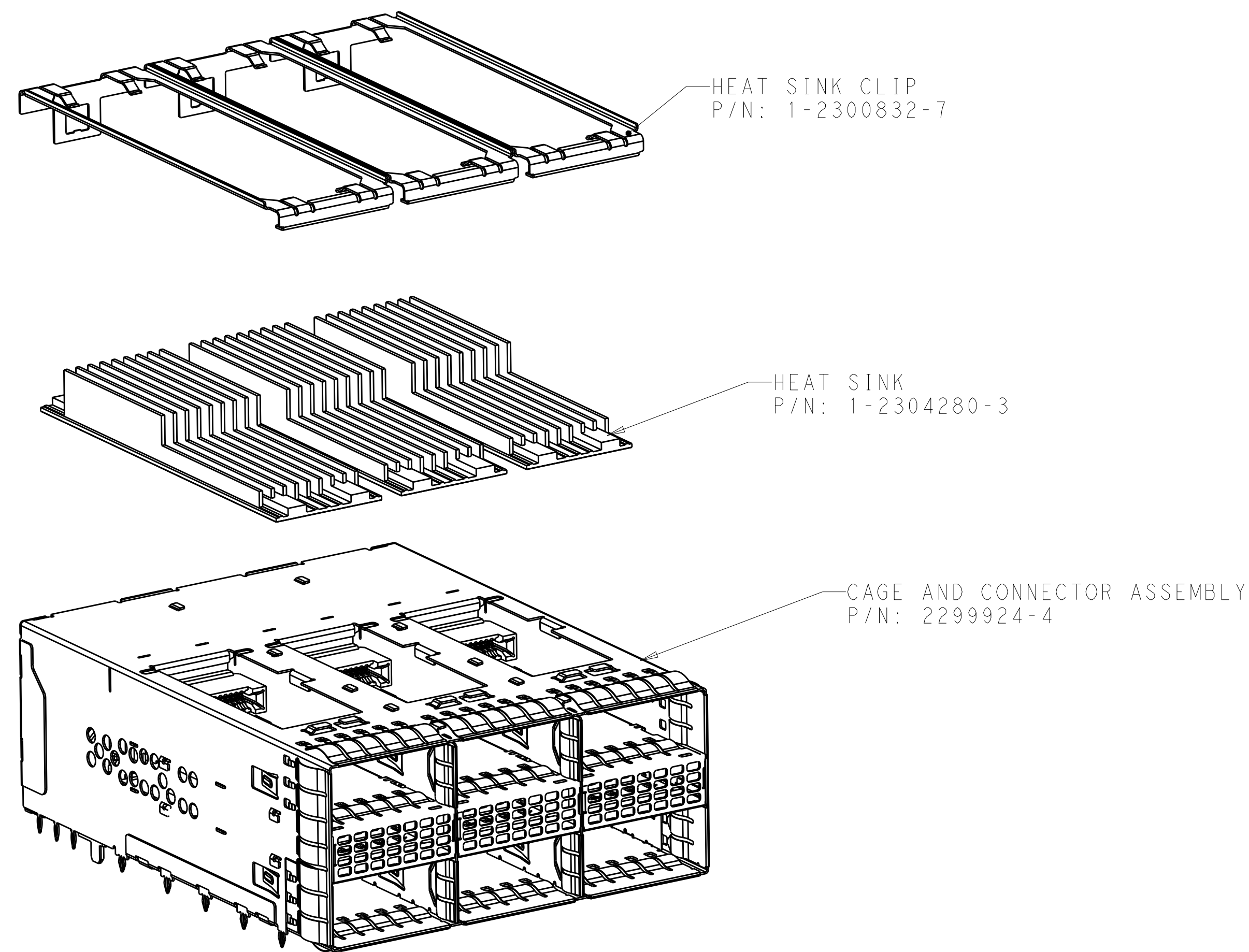

SCALE 2:1

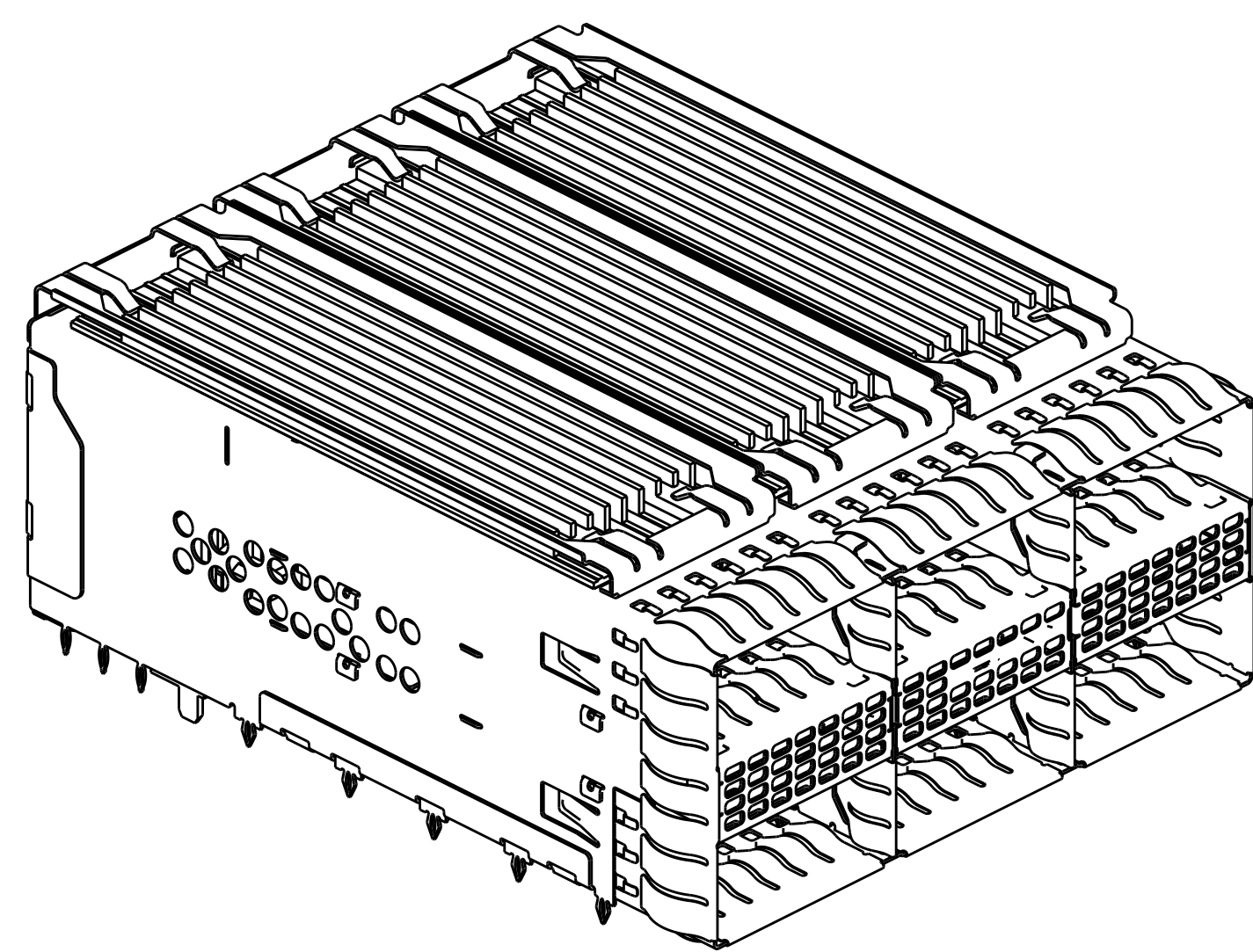

SCALE 2:1

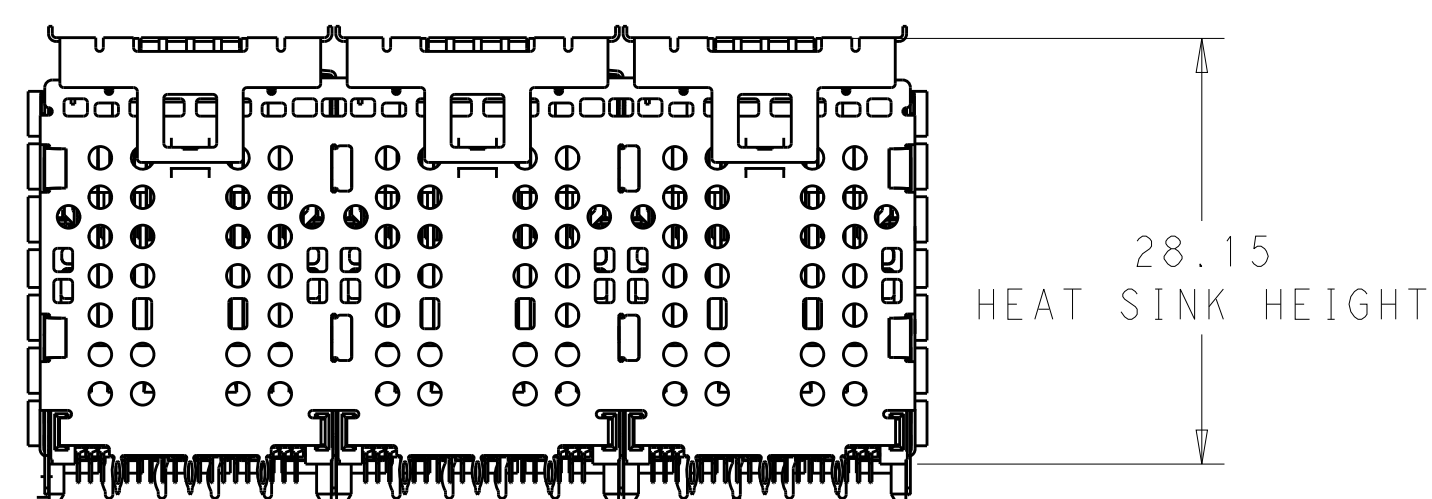

1-2299924-3 AS SHOWN
SCALE 2:1

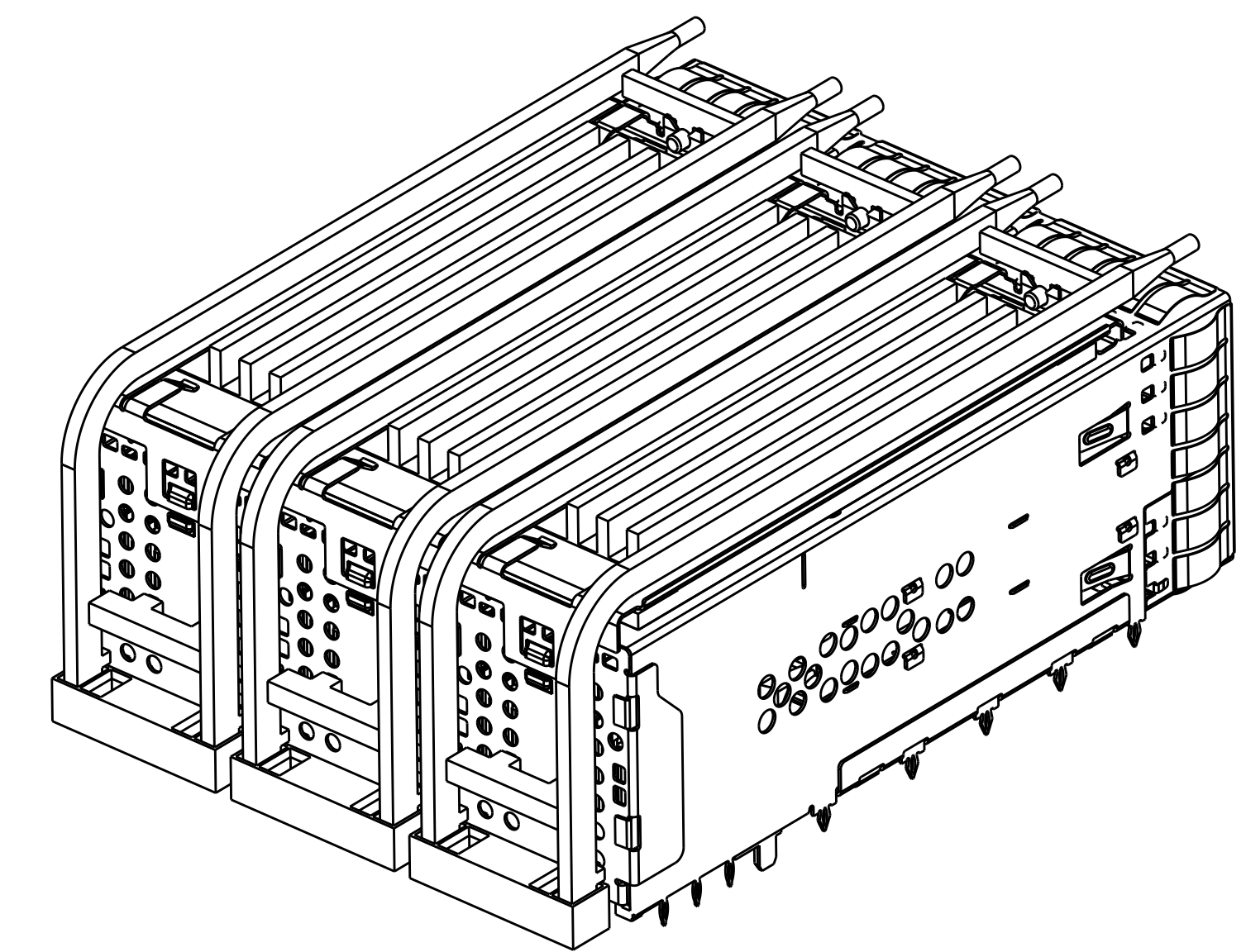

SCALE 2:1

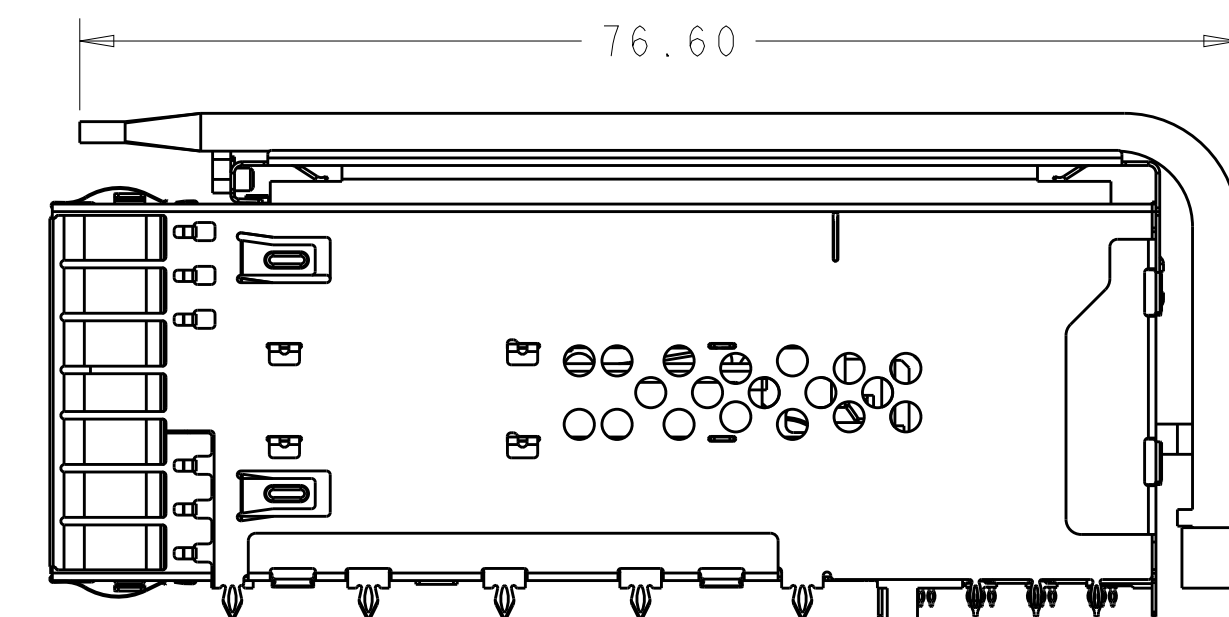

SCALE 2:1

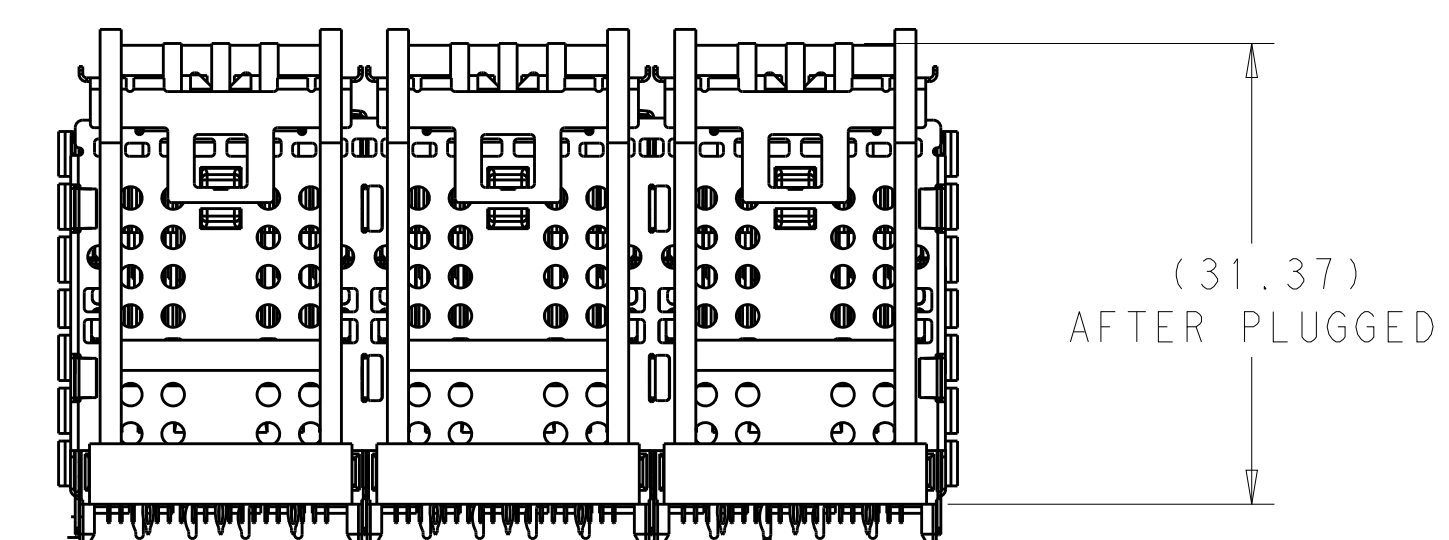

2299924-8 AS SHOWN
SCALE 2:1

3	1-2300832-7	HEAT SINK CLIP	3
3	1-2304280-3	HEAT SINK	2
1	2299924-4	CAGE AND CONNECTOR ASSEMBLY	1
2299924-3	PART NUMBER	DESCRIPTION	ITEM

THIS DRAWING IS A CONTROLLED DOCUMENT.		OWN: ARTHUR JIN 20JAN2016	TE Connectivity
DIMENSIONS: mm		CHK: SEAN HAN 20JAN2016	
TOLERANCES UNLESS OTHERWISE SPECIFIED:		APVD: SEAN HAN 20JAN2016	NAME: CAGE AND CONNECTOR ASSEMBLY WITH EMI SPRING FINGERS, THRU BEZEL, 2X3 ZOSFP+ STACKED WITH HS
0 PLC ±	1 PLC ±0.25	PRODUCT SPEC	SIZE: CAGE CODE DRAWING NO. RESTRICTED TO
2 PLC ±0.15	3 PLC ±	APPLICATION SPEC	A100779C=2299924
4 PLC ±	ANGLES ±	WEIGHT	SCALE 1:1 SHEET 4 OF 9 REV D
MATERIAL: SEE NOTE 1	FINISH: SEE NOTE 2	CUSTOMER DRAWING	

LOC	DIST	REV	DATE	BY	APPD
GP	00				

REVISIONS					
NO.	DATE	DESCRIPTION	BY	APPD	REV
-	-	SEE SHEET 1	-	-	-

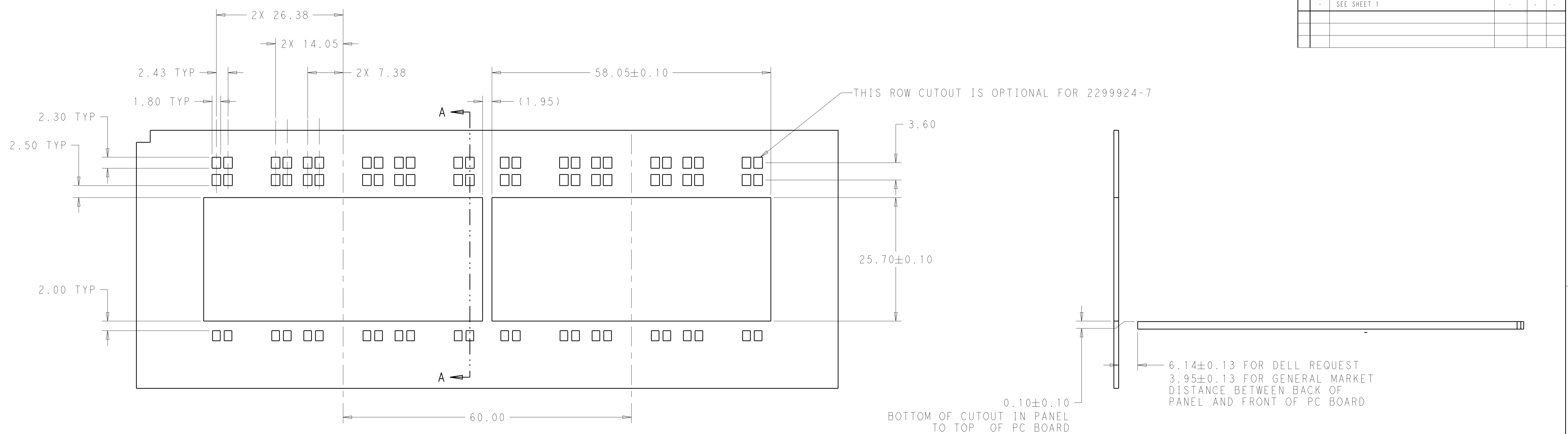

RECOMMENDED PANEL CUTOUT AND PC BOARD, PANEL POSITION
 SCALE 5:2

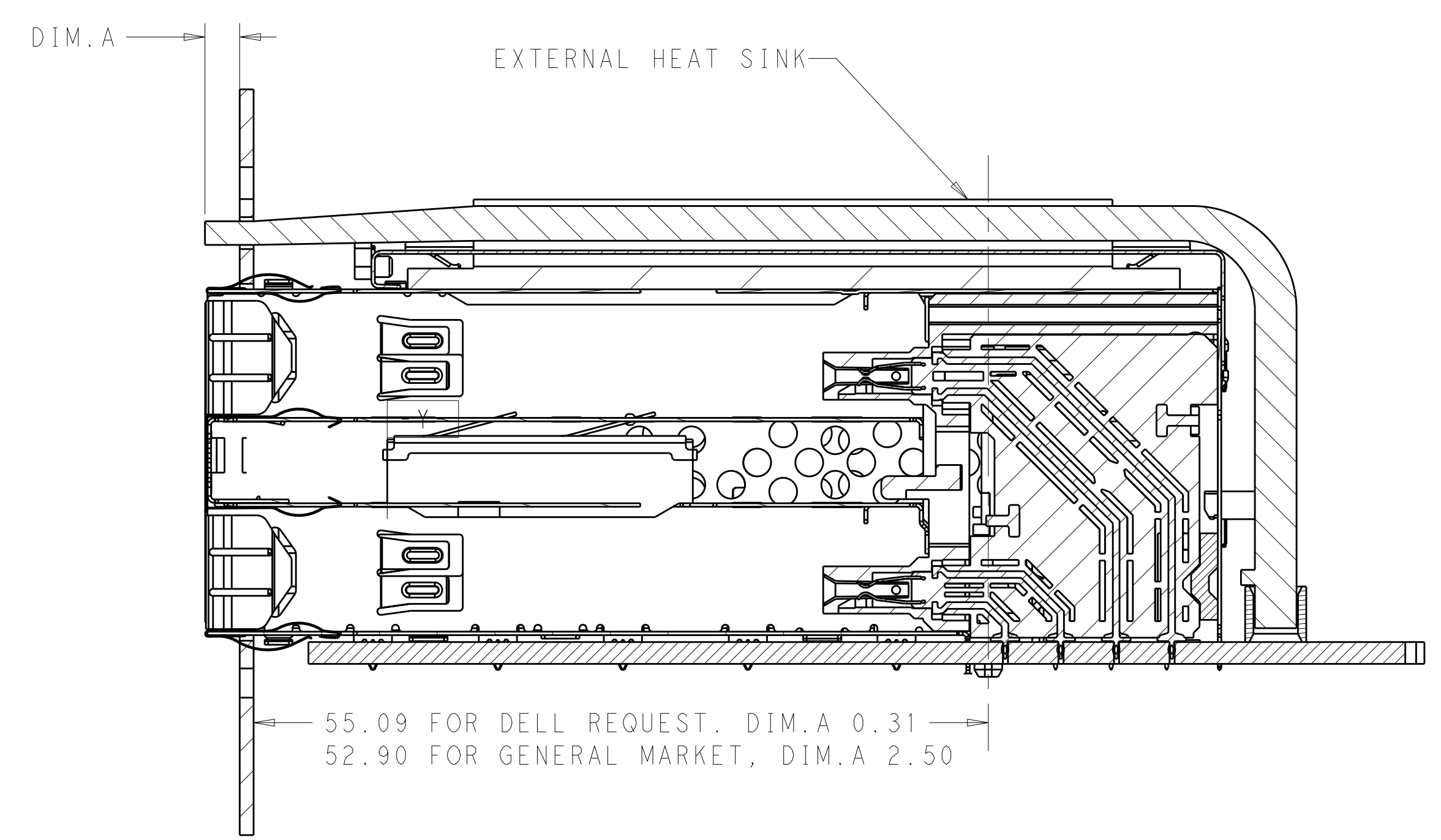

SECTION A-A
 SCALE 3:1

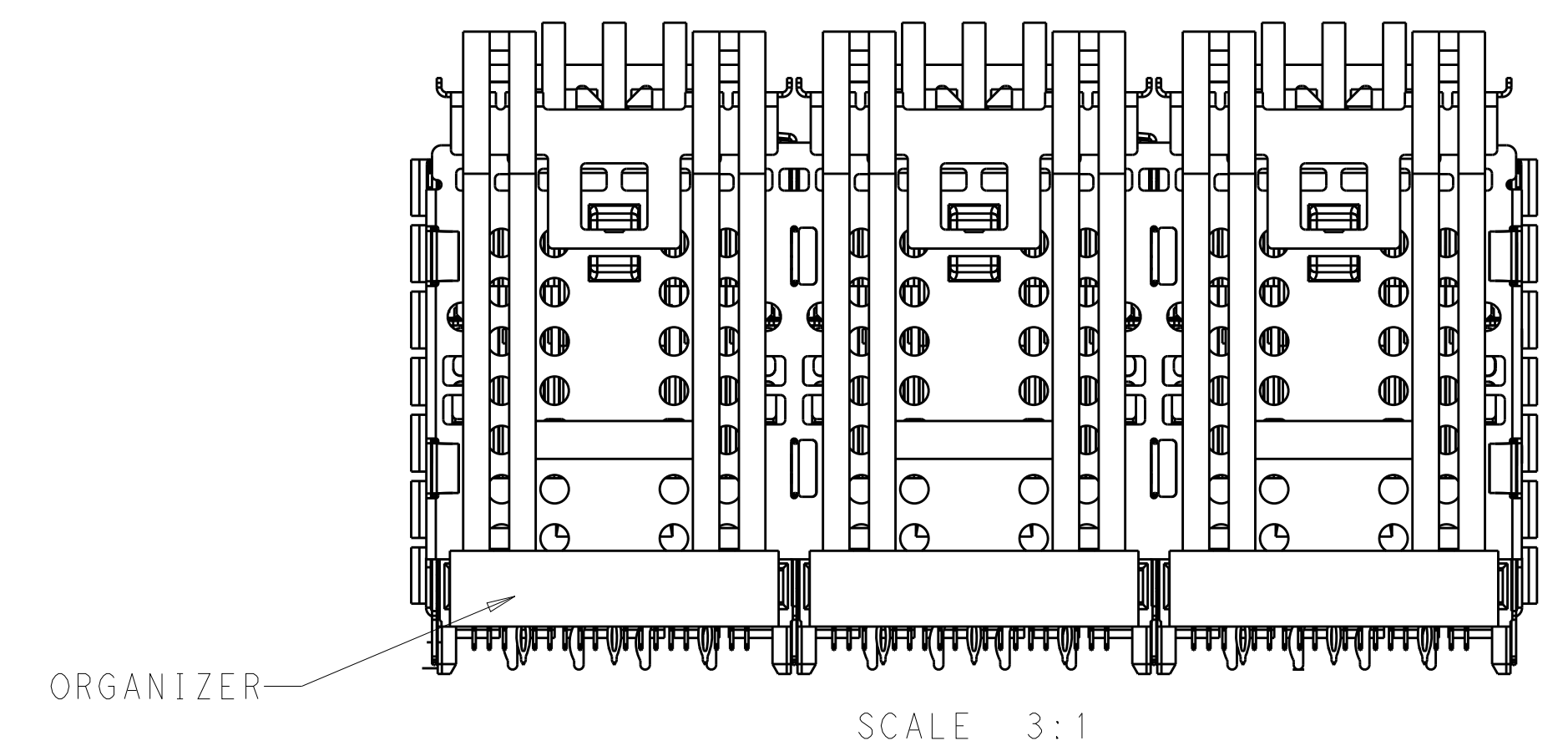

ORGANIZER
 SCALE 3:1

THIS DRAWING IS A CONTROLLED DOCUMENT.		OWN: ARTHUR JIH 20JAN2016	TE Connectivity
DIMENSIONS: mm		CHK: SEAN HAN 20JAN2016	
TOLERANCES UNLESS OTHERWISE SPECIFIED:		APPD: SEAN HAN 20JAN2016	NAME: CAGE AND CONNECTOR ASSEMBLY WITH EMI SPRING FINGERS, THRU BEZEL, 2X3 ZOSFP+ STACKED WITH HS
0 PLC ±	1 PLC ±0.25	PRODUCT SPEC	SIZE: CAGE CODE DRAWING NO. RESTRICTED TO
2 PLC ±0.15	3 PLC ±	APPLICATION SPEC	A100779C=2299924
4 PLC ±	ANGLES ±	WEIGHT	SCALE 1:1 SHEET 5 OF 9 REV D
MATERIAL: SEE NOTE 1	FINISH: SEE NOTE 2	CUSTOMER DRAWING	

LOC	DIST	REVISIONS			
P	LTN	DESCRIPTION	DATE	OWN	APVD
-	-	SEE SHEET 1	-	-	-

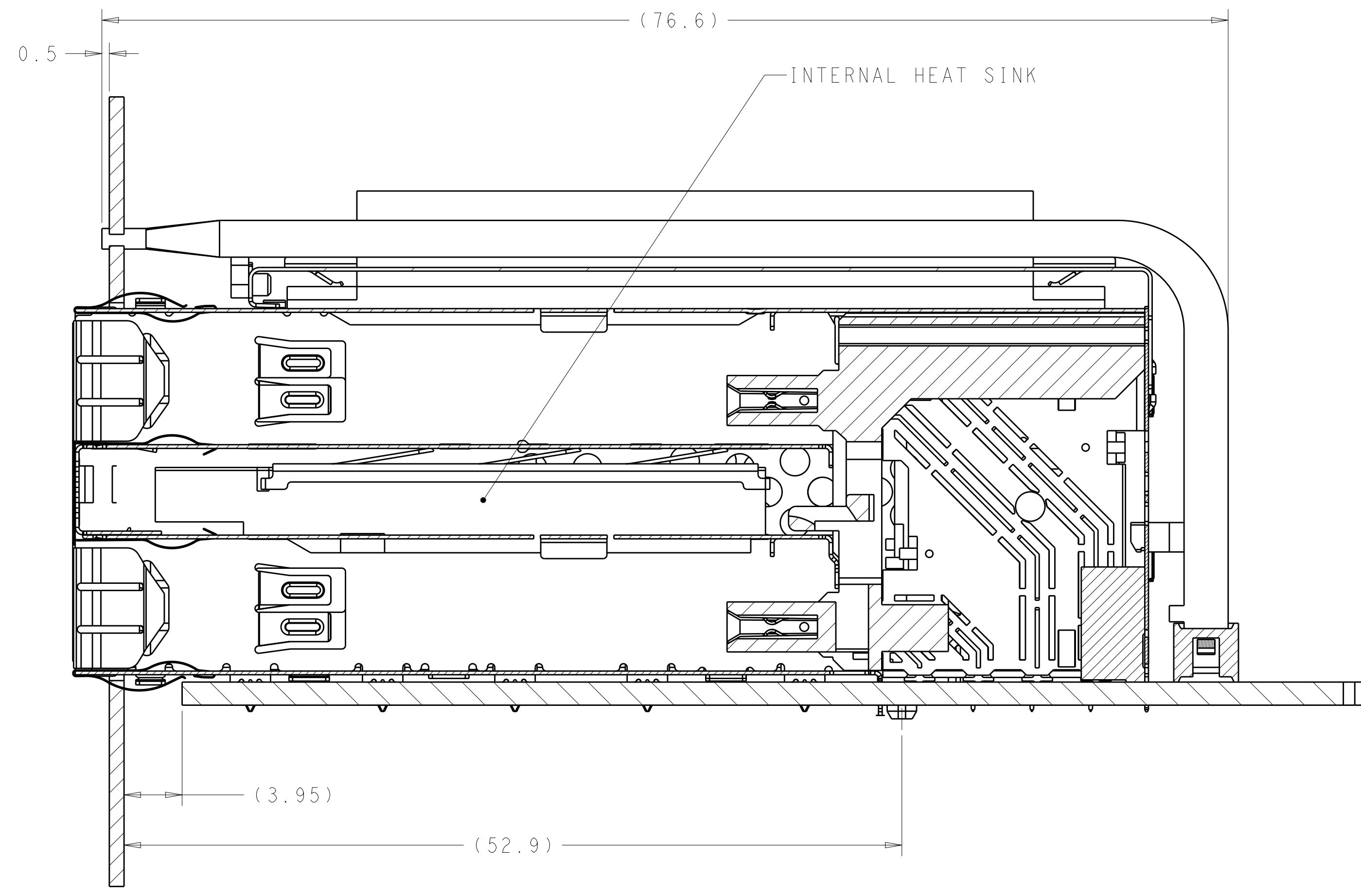

2299924-6
 1-2299924-6
 SECTION V-V
 SCALE 4:1

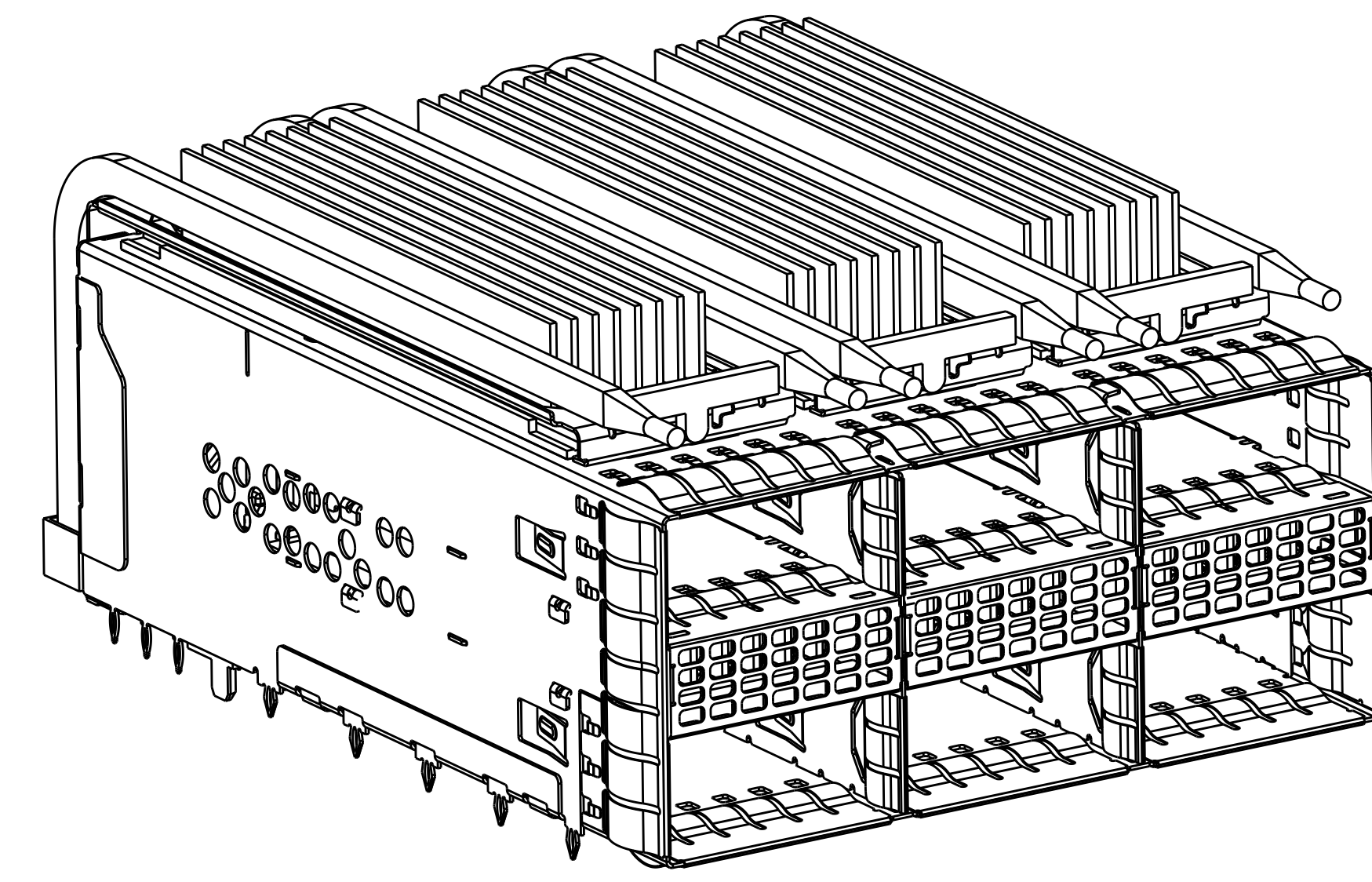

2299924-6
 SCALE 5:2

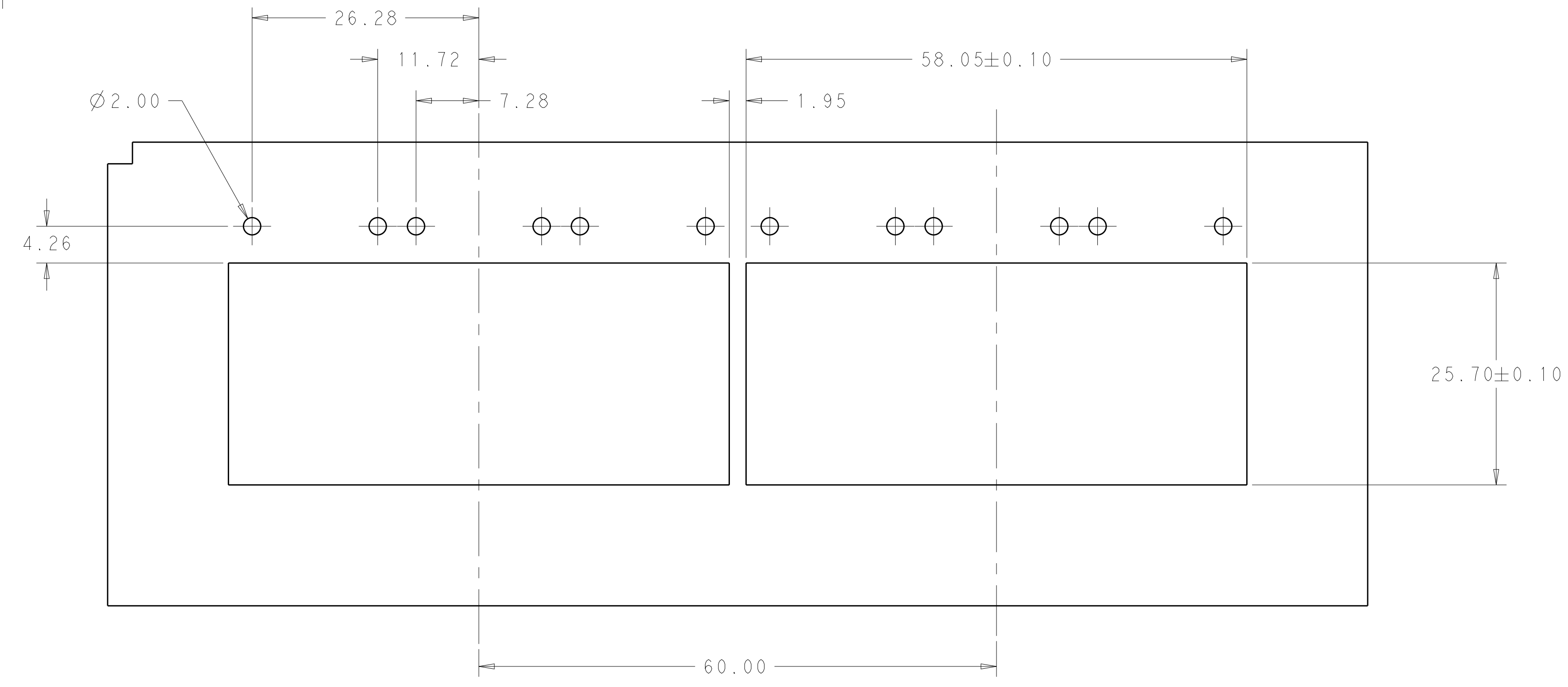

2299924-6
 1-2299924-0
 1-2299924-6
 RECOMMENDED PANEL CUTOUT
 SCALE 5:2

THIS DRAWING IS A CONTROLLED DOCUMENT.		OWN: ARTHUR JIN 20JAN2016	TE Connectivity
DIMENSIONS: mm		CHK: SEAN HAN 20JAN2016	
TOLERANCES UNLESS OTHERWISE SPECIFIED:		APVD: SEAN HAN 20JAN2016	NAME: CAGE AND CONNECTOR ASSEMBLY WITH EMI SPRING FINGERS, THRU BEZEL, 2X3 ZOSFP+ STACKED WITH HS
0 PLC ±	1 PLC ±0.25	PRODUCT SPEC	SIZE: A100779
2 PLC ±0.15	3 PLC ±	APPLICATION SPEC	CAGE CODE: C=2299924
4 PLC ±	ANGLES ±	WEIGHT	RESTRICTED TO
MATERIAL: SEE NOTE 1	FINISH: SEE NOTE 2	CUSTOMER DRAWING	SCALE: 1:1 SHEET 6 OF 9 REV D

LOC	DIST	REVISIONS					
GP	00	P	LYR	DESCRIPTION	DATE	DWN	APVD
-	-	-	-	SEE SHEET 1	-	-	-

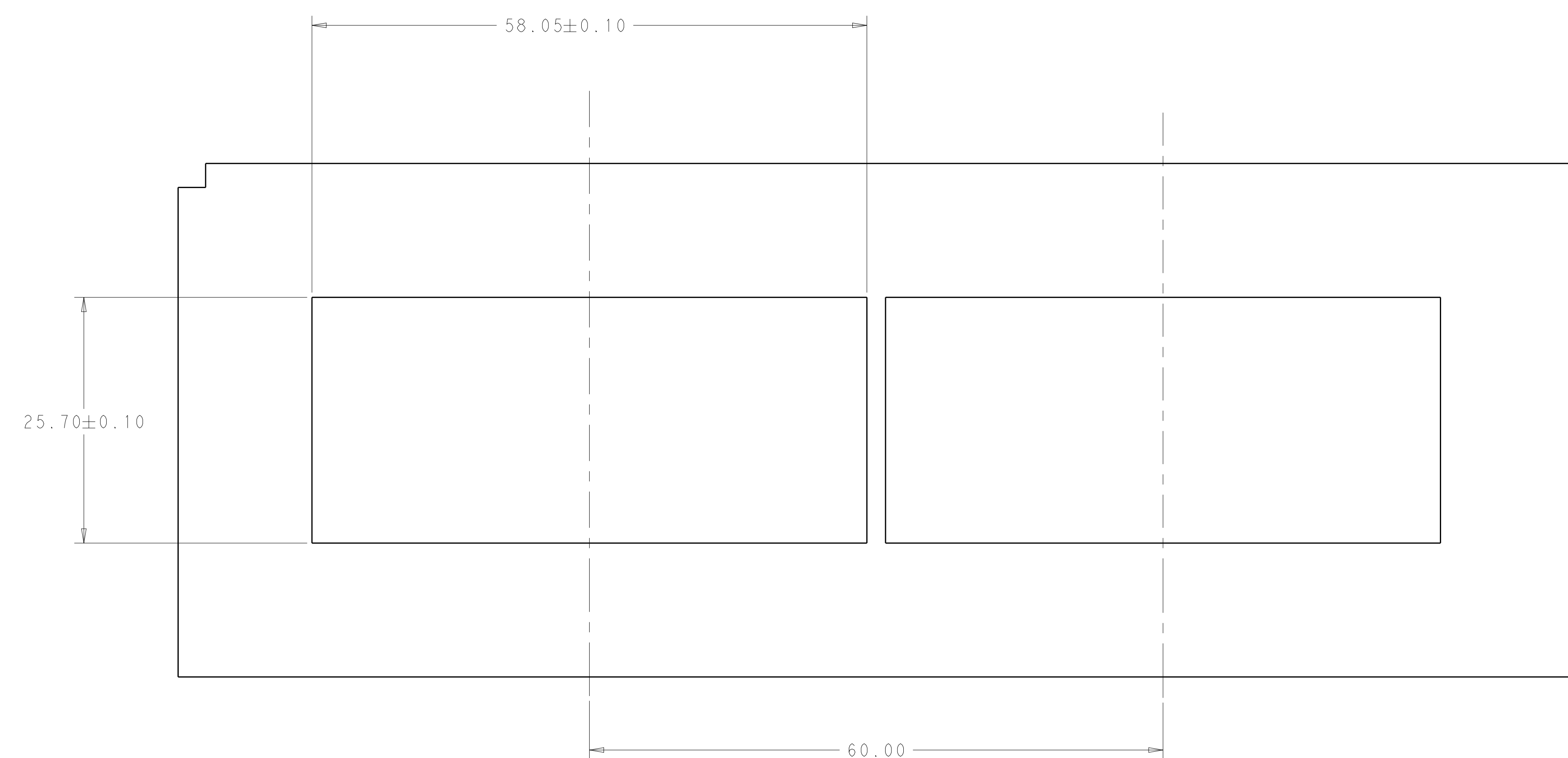

RECOMMENDED PANEL CUTOUT
 SCALE 3:1

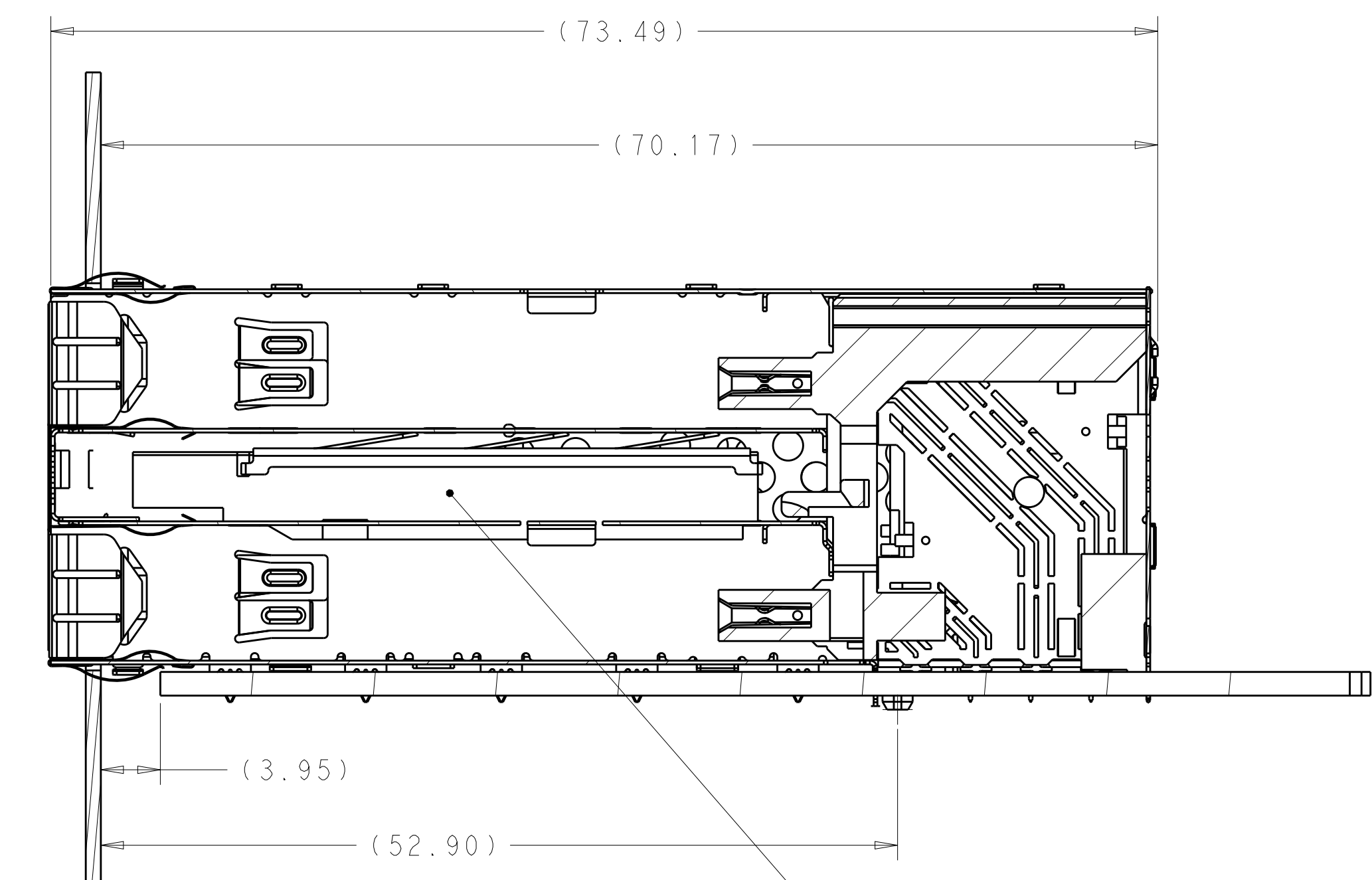

INTERNAL HEATSINK

2-2299924-4
 SECTION V-V
 SCALE 3:1

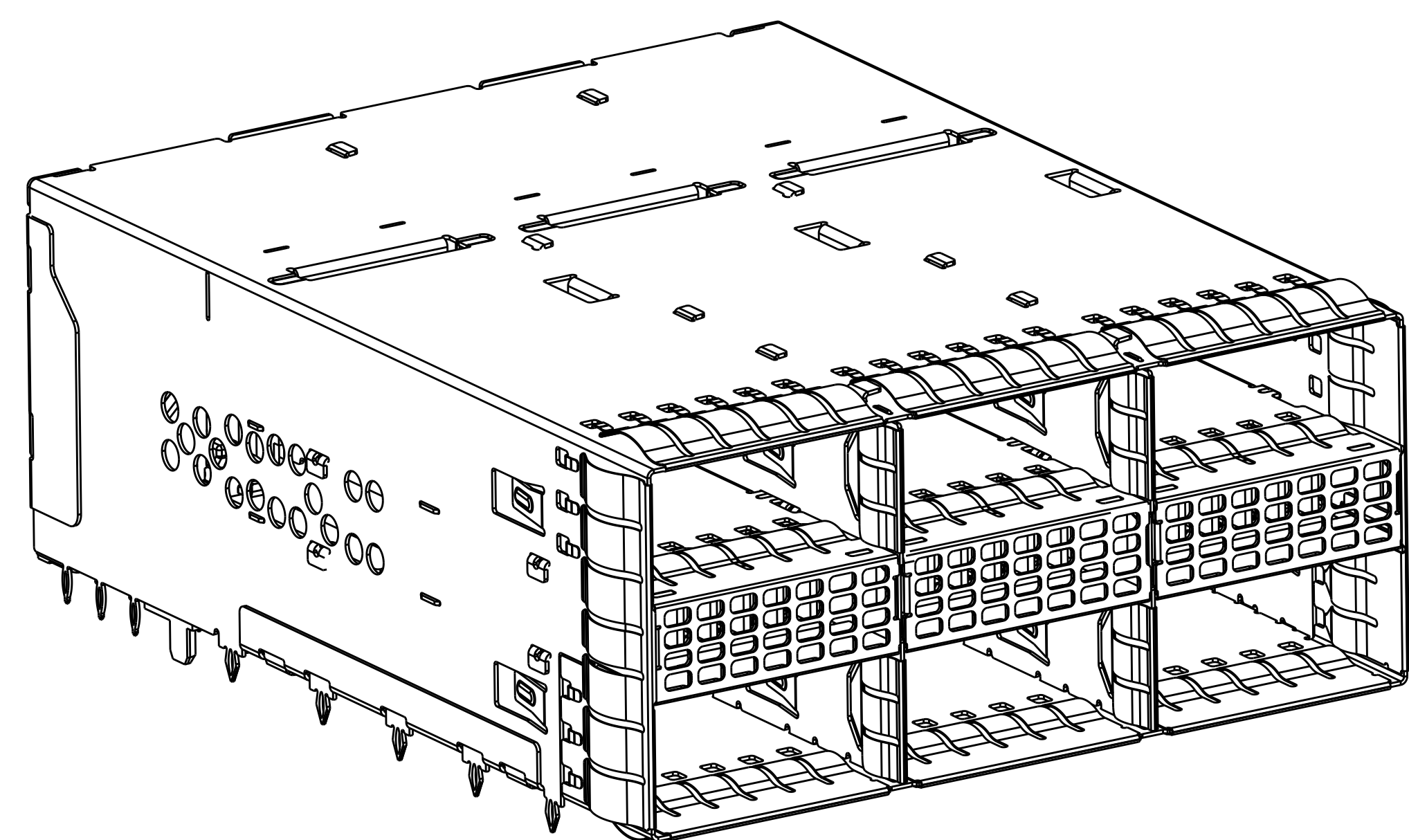

SCALE 3:1

THIS DRAWING IS A CONTROLLED DOCUMENT.		DWN: ARTHUR JIN 20JAN2016	TE Connectivity
DIMENSIONS: mm		CHK: SEAN HAN 20JAN2016	
TOLERANCES UNLESS OTHERWISE SPECIFIED:		APVD: SEAN HAN 20JAN2016	NAME: CAGE AND CONNECTOR ASSEMBLY WITH EMI SPRING FINGERS, THRU BEZEL, 2X3 ZQSFP+ STACKED WITH HS
0 PLC ±	1 PLC ±0.25	PRODUCT SPEC	SIZE: A100779
2 PLC ±0.15	3 PLC ±	APPLICATION SPEC	CAGE CODE: C=2299924
4 PLC ±	ANGLES ±	WEIGHT	RESTRICTED TO
MATERIAL: SEE NOTE 1	FINISH: SEE NOTE 2	CUSTOMER DRAWING	SCALE: 1:1 SHEET 7 OF 9 REV D

LOC	DIST	REV	DATE	BY	APPD
GP	00				
DESCRIPTION			DATE	OWN	APPD
SEE SHEET 1					

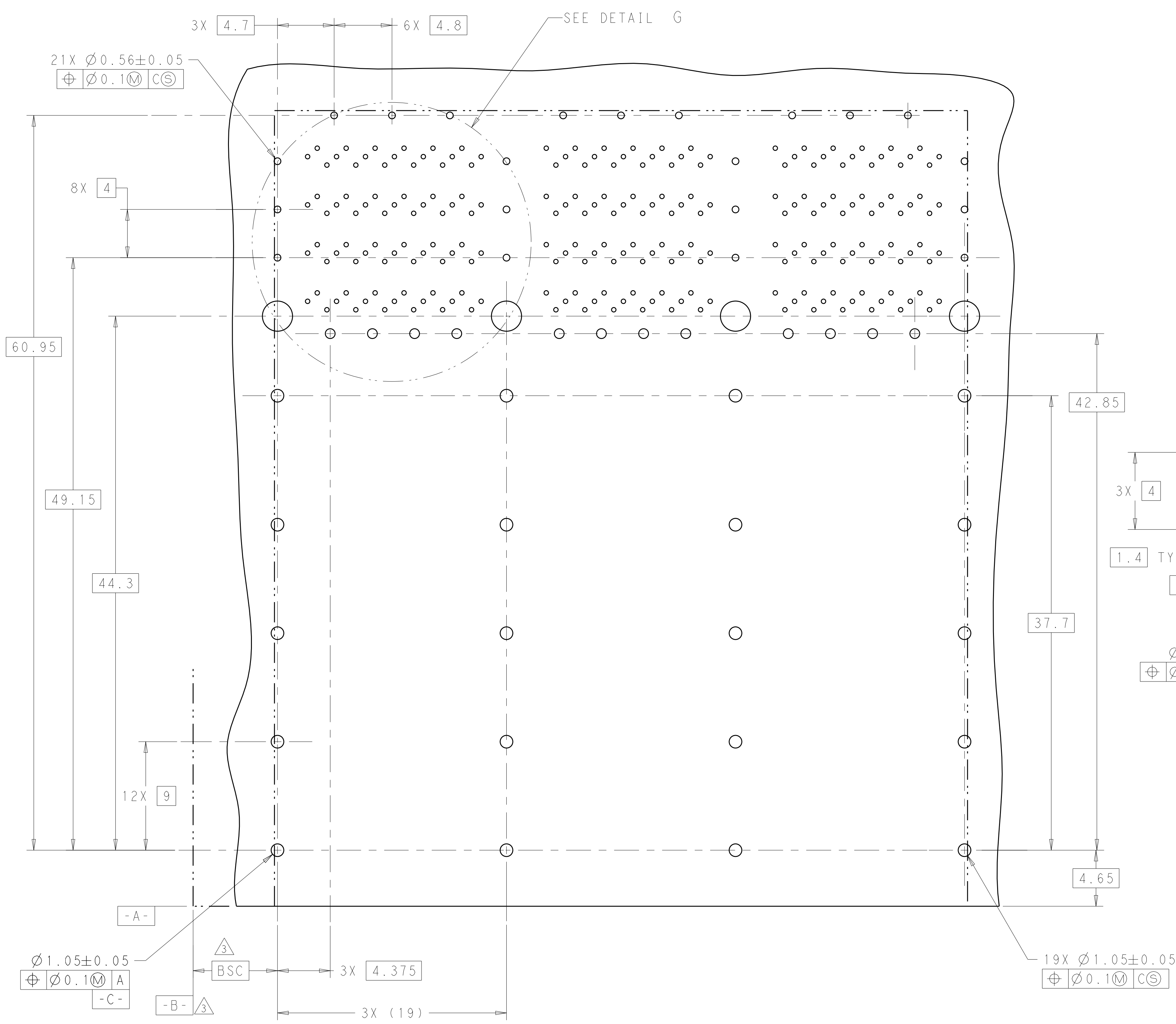

RECOMMENDED PCB BOARD LAYOUT
 COMPONENT SIDE OF BOARD
 PCB TOLERANCE: ± 0.05
 SCALE 5:1

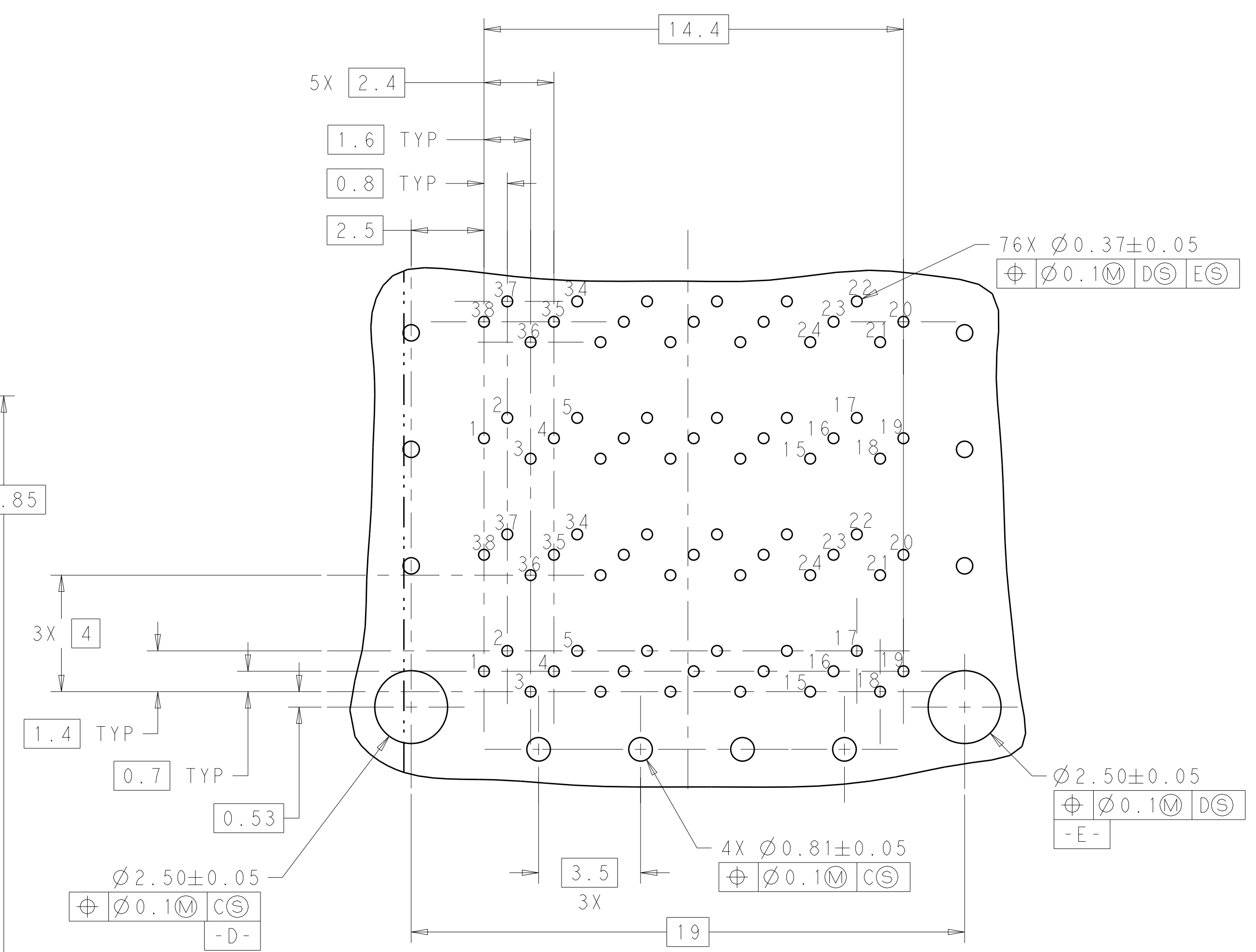

THIS DRAWING IS A CONTROLLED DOCUMENT.		OWN: ARTHUR JIN 20JAN2016	TE Connectivity
DIMENSIONS: mm		CHK: SEAN HAN 20JAN2016	
TOLERANCES UNLESS OTHERWISE SPECIFIED:		APPD: SEAN HAN 20JAN2016	NAME: CAGE AND CONNECTOR ASSEMBLY WITH EMI SPRING FINGERS, THRU BEZEL, 2X3 ZQSF+ STACKED WITH HS
0 PLC ± 0.25	1 PLC ± 0.15	PRODUCT SPEC	SIZE: CAGE CODE DRAWING NO. RESTRICTED TO
2 PLC ± 0.15	3 PLC ± 0.15	APPLICATION SPEC	A100779C=2299924
4 PLC ± 0.15	ANGLES ± 0.15	WEIGHT	SCALE 1:1 SHEET 8 OF 9 REV D
MATERIAL: SEE NOTE 1	FINISH: SEE NOTE 2	CUSTOMER DRAWING	

LOC		DIST		REVISIONS			
GP	00	P	LTN	DESCRIPTION	DATE	OWN	APVD
				SEE SHEET 1			

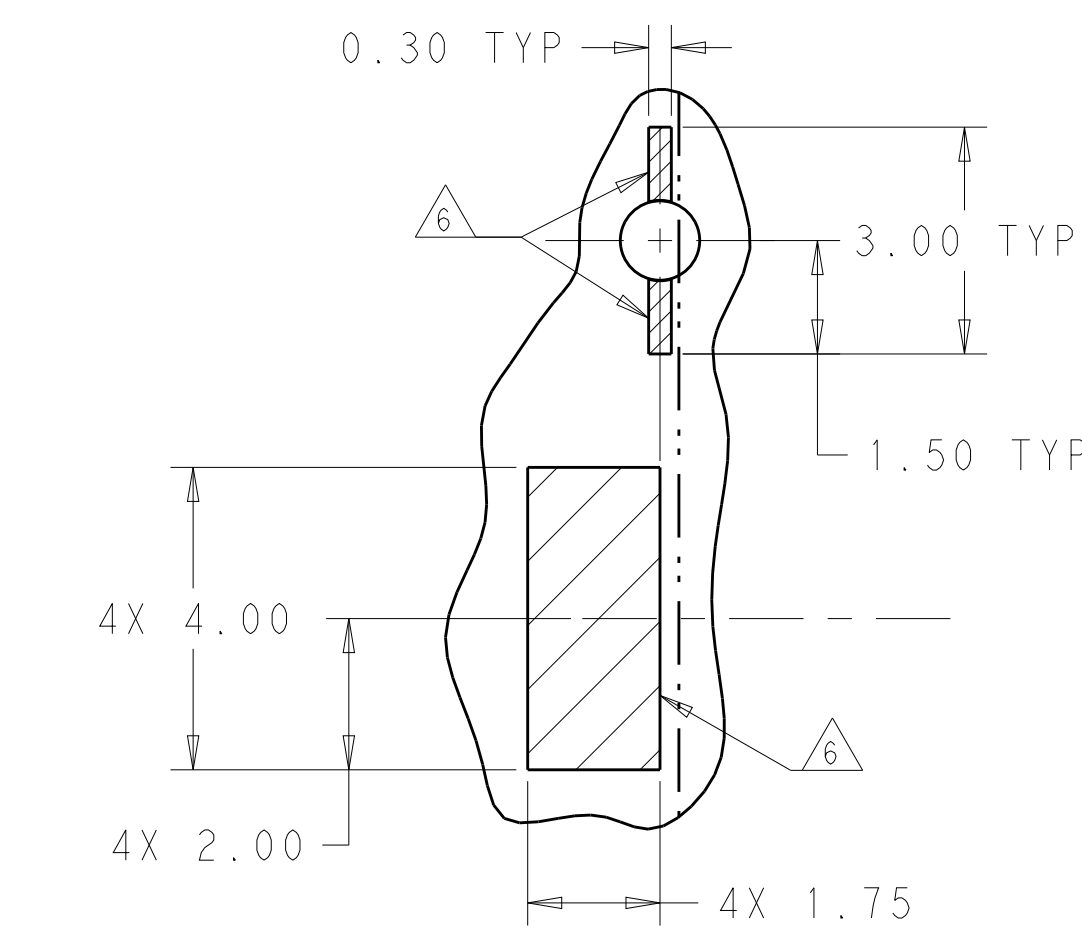
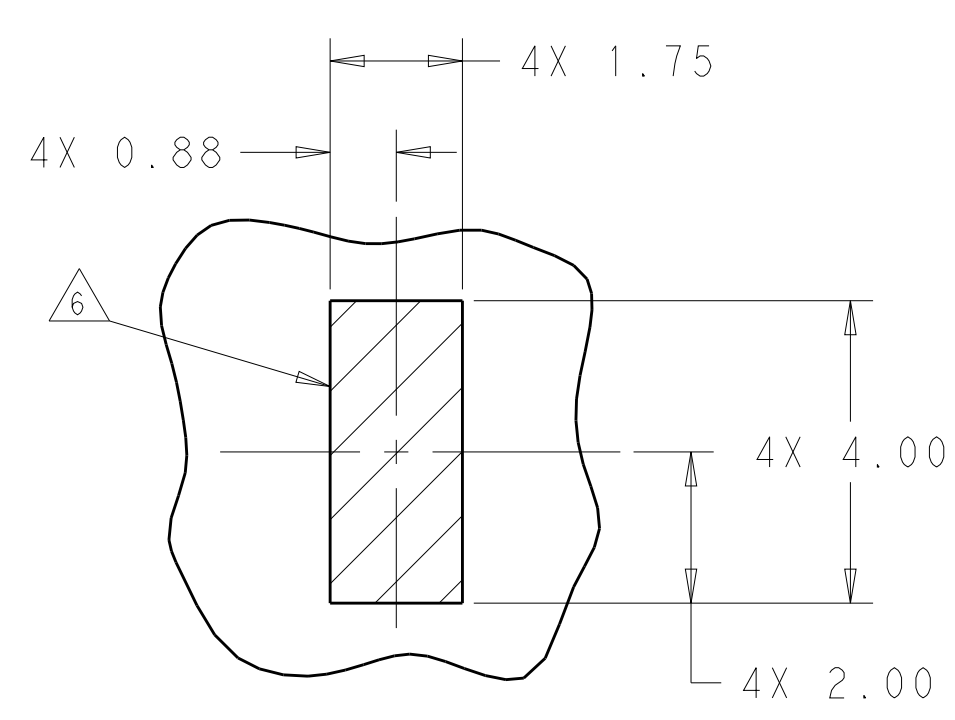
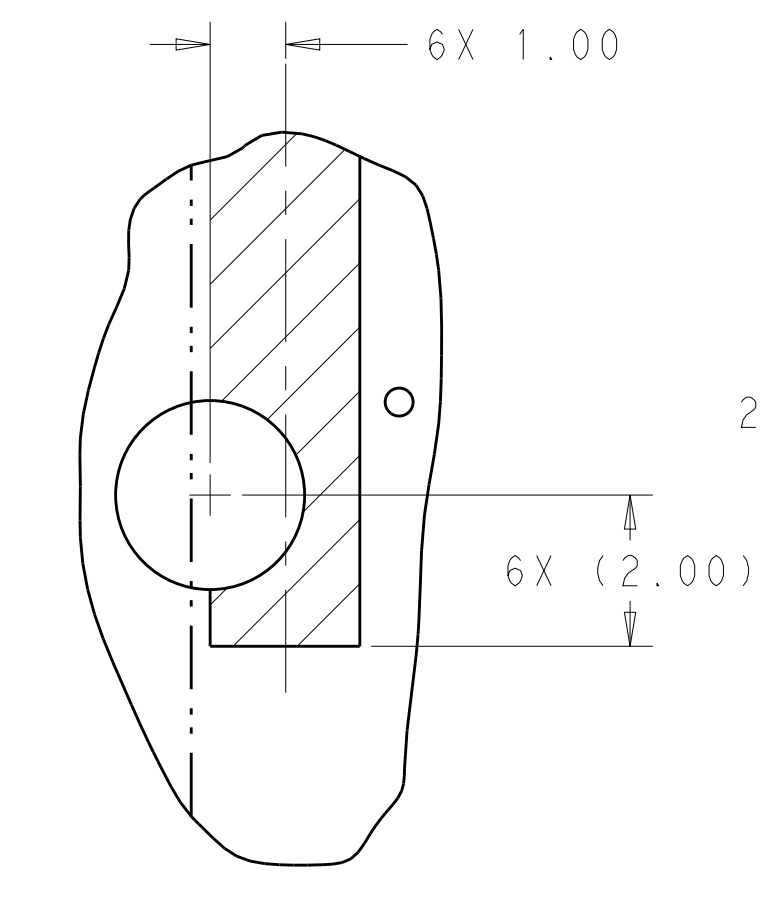
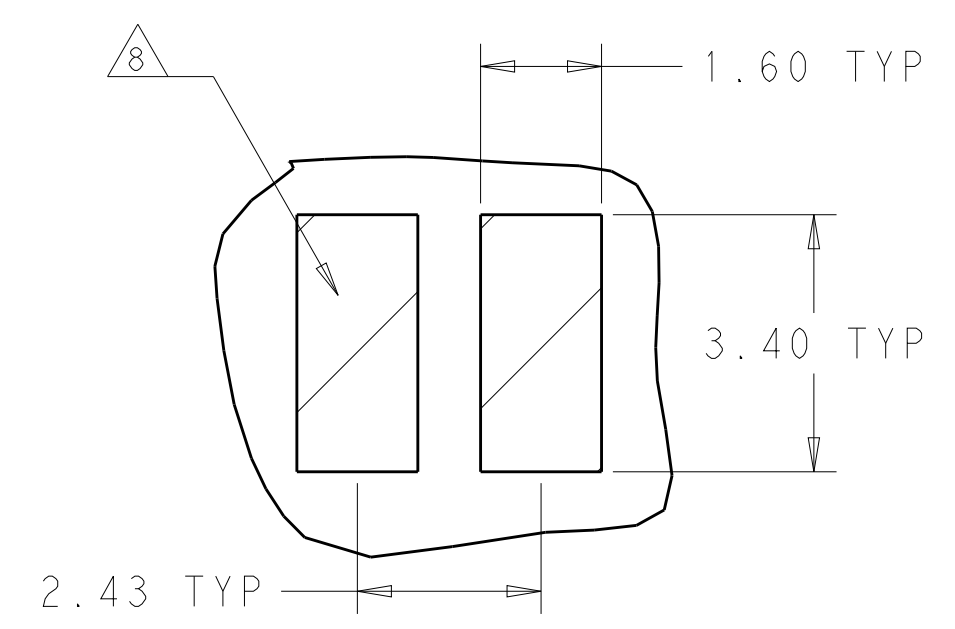
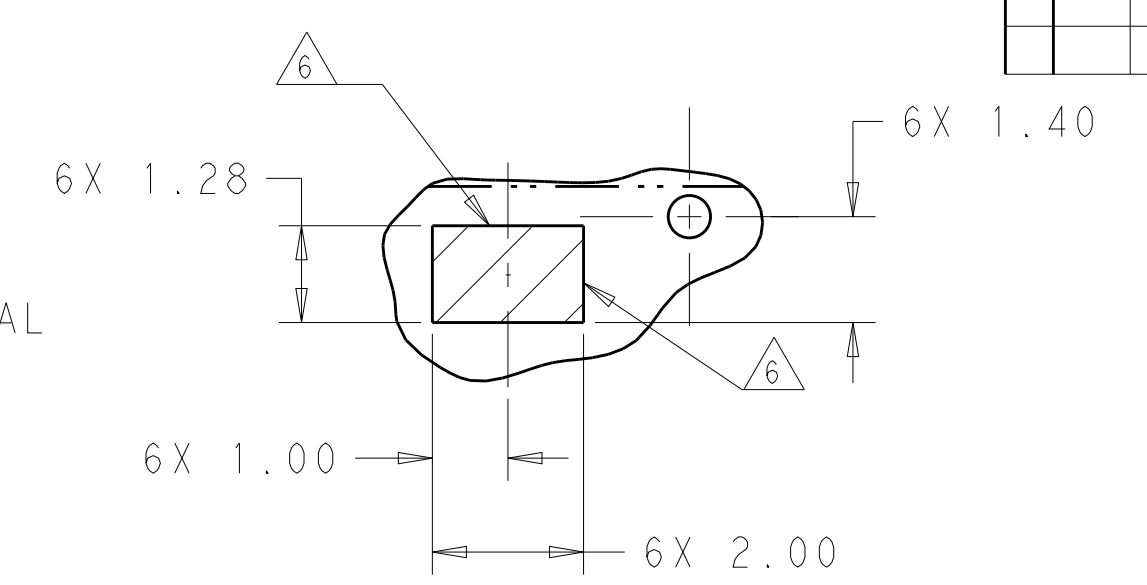
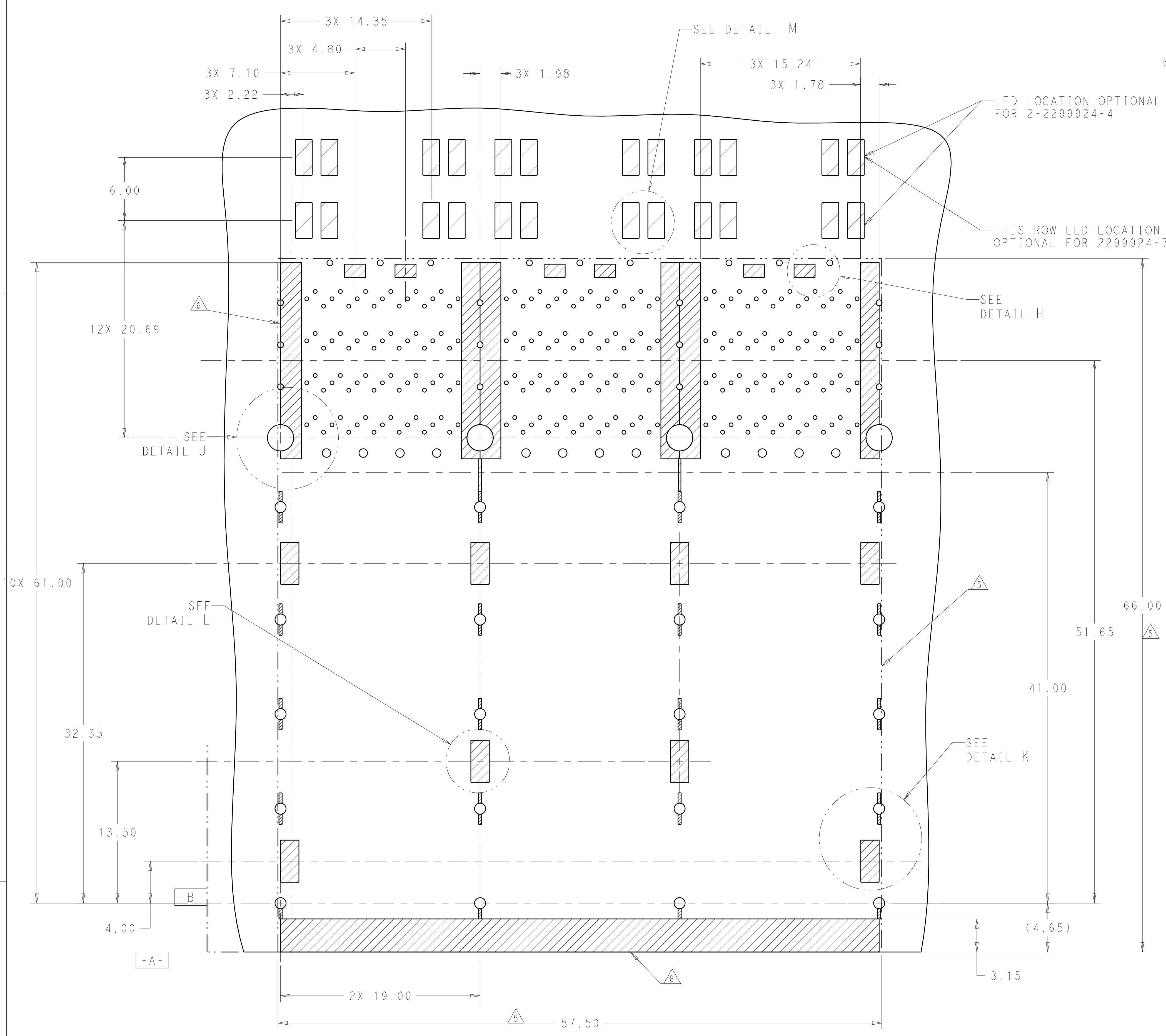

KEEPOUT AREAS COMPONENT
 SIDE OF BOARD FOR 4 LP
 SCALE 5:1

THIS DRAWING IS A CONTROLLED DOCUMENT.		OWN: ARTHUR JIH 20JAN2016	TE Connectivity
DIMENSIONS: mm		CHK: SEAN HAN 20JAN2016	
TOLERANCES UNLESS OTHERWISE SPECIFIED:		APVD: SEAN HAN 20JAN2016	NAME: CAGE AND CONNECTOR ASSEMBLY WITH EMI SPRING FINGERS, THRU BEZEL, 2X3 ZOSFP+ STACKED WITH HS
0 PLC ± 1 PLC ±0.25 2 PLC ±0.15 3 PLC ± 4 PLC ± ANGLES ±		PRODUCT SPEC	
MATERIAL: SEE NOTE 1	FINISH: SEE NOTE 2	WEIGHT: -	RESTRICTED TO: -
CUSTOMER DRAWING		SCALE: 1:1	SHEET 9 OF 9 REV D