

## System connection - PLC-V8L/FLK14/OUT - 2299660

Please be informed that the data shown in this PDF Document is generated from our Online Catalog. Please find the complete data in the user's documentation. Our General Terms of Use for Downloads are valid (<http://phoenixcontact.com/download>)



V8 adapter for 8 x PLC-INTERFACE (14 mm), controller: PLC system cabling of output cards, connection 1: Screw connection 1x, connection 2: IDC/FLK pin strip 1x 14-position, connection 3: Plug connection (Can be snapped onto 8x PLC-INTERFACE terminals), number of channels: 8, control logic: positive switching

RoHS

### Key Commercial Data

Packing unit	1 pc
GTIN	 4 017918 893163
GTIN	4017918893163
Weight per Piece (excluding packing)	80.000 g
Custom tariff number	85369010
Country of origin	Germany

### Technical data

#### Dimensions

Width	112.5 mm
Height	39 mm
Depth	56 mm

#### Ambient conditions

Ambient temperature (operation)	-40 °C ... 70 °C
Ambient temperature (storage/transport)	-40 °C ... 70 °C
Degree of protection	IP20

#### General

Max. permissible operating voltage	30 V DC
Nominal voltage $U_N$	24 V DC

## System connection - PLC-V8L/FLK14/OUT - 2299660

### Technical data

#### General

Max. perm. current (per branch)	1 A (per signal path)
Max. permissible current (separate power supply)	3 A
Number of positions	14
Status display	Green LED
Mounting position	any
Assembly instructions	In rows with zero spacing
Degree of protection	IP20

#### Connection data

Connection name	Supply
Connection method	Screw connection
Stripping length	8 mm
Screw thread	M3
Number of connections	1
Conductor cross section solid	0.2 mm <sup>2</sup> ... 4 mm <sup>2</sup>
Conductor cross section flexible	0.2 mm <sup>2</sup> ... 2.5 mm <sup>2</sup>
Conductor cross section AWG	24 ... 12

#### Connection data 2

Connection name	Controller level
Connection method	IDC/FLK pin strip
Number of connections	1
Number of positions	14
Pitch	2.54 mm

#### Connection data 3

Connection name	Field level
Connection method	Plug connection
Note	Can be snapped onto 8x PLC-INTERFACE terminals

#### Supported controller

Controller	SIEMENS S7-1500
- suitable I/O card	6ES7 522-1BH00-0AB0
	6ES7 522-1BH01-0AB0
	6ES7 522-1BL00-0AB0
	6ES7 522-1BL01-0AB0
Controller	SIEMENS S7-400
- suitable I/O card	6ES7 422-1BL00-0AA0
	6ES7 422-1BL00-0AA0

## System connection - PLC-V8L/FLK14/OUT - 2299660

### Technical data

#### Supported controller

Controller	ALLEN-BRADLEY ControlLogix
- suitable I/O card	1756-OB32
	1756-OB16E
Controller	ALLEN-BRADLEY PLC 5
- suitable I/O card	1771 OBN
Controller	ALLEN-BRADLEY SLC 500
- suitable I/O card	1746 OB 32
Controller	HONEYWELL Experion PKS C200
- suitable I/O card	TC-ODD 321
Controller	MITSUBISHI MELSEC Q
- suitable I/O card	QY81P
	QY82P
Controller	SIEMENS S7-300 / ET 200 M
- suitable I/O card	CPU 313C-2DP
	CPU 314C-2DP
	CPU 314C-2PtP
	6ES7 322-1BH01-0AA0
	6ES7 322-1BL00-0AA0
	6ES7 323-1BH01-0AA0
	6ES7 323-1BL00-0AA0
	CPU 313C
	CPU 313C-2PtP
Controller	ABB S800 I/O
- suitable I/O card	DO810
	DO840
Controller	Emerson DeltaV
- suitable I/O card	VE4002S1T1B3
	VE4002S1T2B3
	VE4002S1T2B3 Series 2
	VE4002S1T2B6
Controller	GE-FANUC RX3i
- suitable I/O card	IC694MDL754
Controller	MITSUBISHI MELSEC L
- suitable I/O card	LY41PT1P
	LY42PT1P

#### Standards and Regulations

Connection in acc. with standard	CUL
----------------------------------	-----

# System connection - PLC-V8L/FLK14/OUT - 2299660

## Technical data

### Standards and Regulations

Standards/regulations	IEC 60664
	DIN EN 50178
Rated insulation voltage	50 V
Rated surge voltage	0.5 kV (Functional insulation)
Degree of pollution	2
Overvoltage category	II
Flammability rating according to UL 94	V0

### Environmental Product Compliance

China RoHS	Environmentally Friendly Use Period = 50
	For details about hazardous substances go to tab "Downloads", Category "Manufacturer's declaration"

## Drawings

Circuit diagram

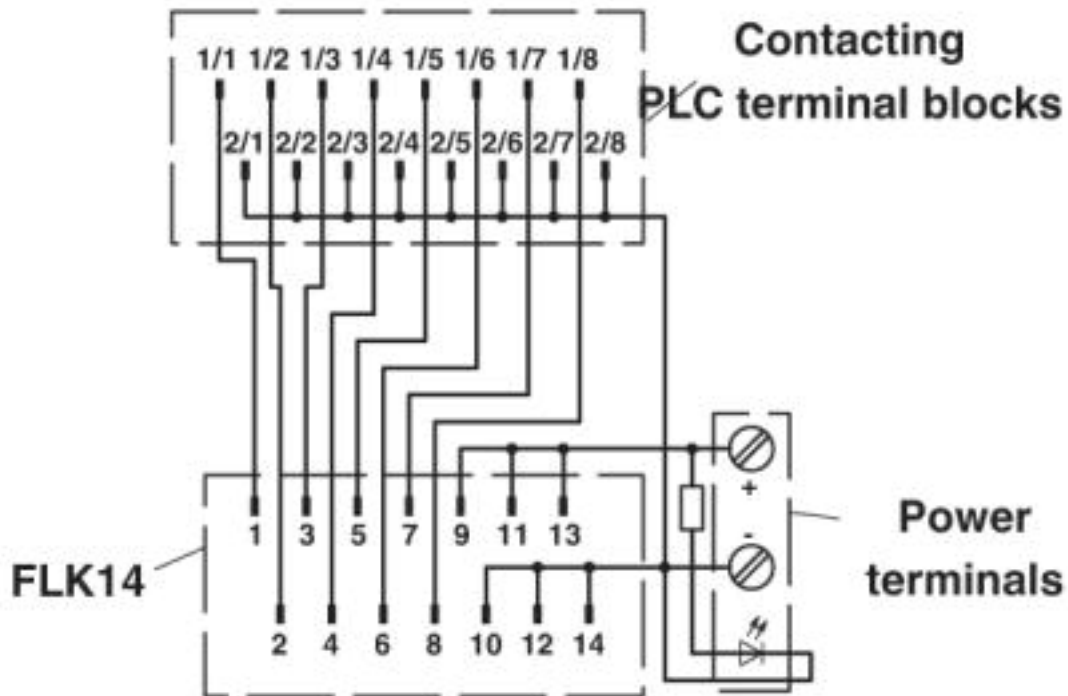

PLC-V8L/FLK14/OUT connection scheme

# System connection - PLC-V8L/FLK14/OUT - 2299660

## Classifications

### eCl@ss

eCl@ss 4.0	27250300
eCl@ss 4.1	27250300
eCl@ss 5.0	27242700
eCl@ss 5.1	27242700
eCl@ss 6.0	27242200
eCl@ss 7.0	27141152
eCl@ss 8.0	27141152
eCl@ss 9.0	27141152

### ETIM

ETIM 5.0	EC002780
ETIM 6.0	EC002780
ETIM 7.0	EC002780

### UNSPSC

UNSPSC 6.01	30211824
UNSPSC 7.0901	39121402
UNSPSC 11	39121402
UNSPSC 12.01	39121402
UNSPSC 13.2	39121432

## Approvals

### Approvals

---

#### Approvals

PRS / GL / UL Listed / UL Recognized / cUL Recognized / cUL Listed / EAC / DNV GL / cULus Recognized / cULus Listed

---

#### Ex Approvals

---

### Approval details

PRS		<a href="http://www.prs.pl/">http://www.prs.pl/</a>	TE/2109/880590/16
-----	--	---	-------------------

# System connection - PLC-V8L/FLK14/OUT - 2299660

## Approvals

GL		<a href="https://approvalfinder.dnvgl.com/">https://approvalfinder.dnvgl.com/</a>	46016-03 HH
----	--	---	-------------

UL Listed		<a href="http://database.ul.com/cgi-bin/XYV/template/LISEXT/1FRAME/index.htm">http://database.ul.com/cgi-bin/XYV/template/LISEXT/1FRAME/index.htm</a>	FILE E 172140
-----------	--	---	---------------

UL Recognized		<a href="http://database.ul.com/cgi-bin/XYV/template/LISEXT/1FRAME/index.htm">http://database.ul.com/cgi-bin/XYV/template/LISEXT/1FRAME/index.htm</a>	FILE E 238705
Nominal voltage UN	24 V		
Nominal current IN	1 A		

cUL Recognized		<a href="http://database.ul.com/cgi-bin/XYV/template/LISEXT/1FRAME/index.htm">http://database.ul.com/cgi-bin/XYV/template/LISEXT/1FRAME/index.htm</a>	FILE E 238705
Nominal voltage UN	24 V		
Nominal current IN	1 A		

cUL Listed		<a href="http://database.ul.com/cgi-bin/XYV/template/LISEXT/1FRAME/index.htm">http://database.ul.com/cgi-bin/XYV/template/LISEXT/1FRAME/index.htm</a>	FILE E 172140
------------	--	---	---------------

EAC			RU C- DE.A*30.B.01742
-----	--	--	--------------------------

DNV GL		<a href="https://approvalfinder.dnvgl.com/">https://approvalfinder.dnvgl.com/</a>	TAE0000196-02
--------	--	---	---------------

cULus Recognized			
------------------	--	--	--

## System connection - PLC-V8L/FLK14/OUT - 2299660

### Approvals

cULus Listed

