

PROPER USE GUIDELINES

Cumulative Trauma Disorders can result from the prolonged use of manually powered hand tools. Hand tools are intended for occasional use and low volume applications. A wide selection of powered application equipment for extended-use, production operations is available.

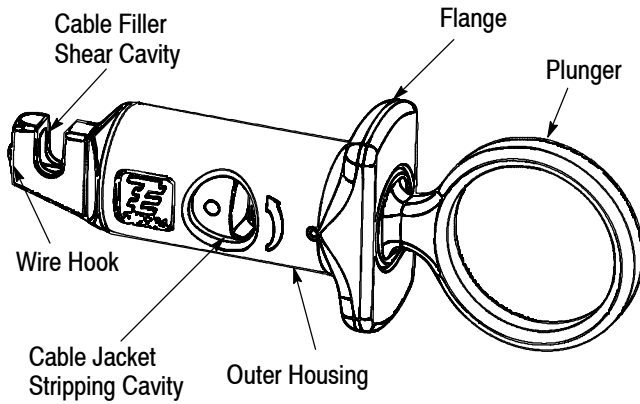

Figure 1

1. INTRODUCTION

JacKnack Telecommunications Cable Preparation Tool 2119000-1 is designed to strip the cable jacket, cut the cable filler, and untwist twisted wire pairs in most Category 5 and Category 6 telecommunications cable. Read these instructions thoroughly before using the tool.

2. DESCRIPTION (Figure 1)

The JackKnack tool consists of an outer housing, a plunger, a cable jacket stripping cavity, a cable filler shear cavity, and a wire hook. The plunger has a loop that is designed to accept a user's finger and the outer housing has two flanges to accept user's fingers. When the plunger is depressed, the cable jacket stripping cavity opens, the cable filler shear blade actuates, and the wire hook extends. The tool is designed to fit comfortably on a user's hand throughout the entire preparation and termination process.

3. STRIPPING THE CABLE JACKET (Figure 2)

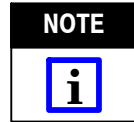

The JackKnack tool is capable of stripping the cable jacket of cables ranging from an outer diameter of 4.83-10.16 mm [.190-.400 in.].

1. To strip the cable jacket, depress the plunger using the finger loop and the housing flanges.
2. While the plunger is extended, place the cable in the cable jacket stripping cavity.
3. Release the plunger, allowing the plunger to retract and the cable jacket stripping blade to pierce the cable jacket.
4. Rotate the tool around the wire in either direction as indicated by the arrow shown in Figure 2. Rotating the tool toward the larger arrow provides a deeper cut while rotating the tool toward the smaller arrow provides a shallower cut.



Care should be taken to avoid cutting or nicking wire insulation. A good practice is to score the cable jacket without breaking through the cable jacket. The cable jacket can be easily removed by hand after scoring.

5. After the cable jacket is cut, depress the plunger again to allow the cable to be removed from the cable jacket stripping cavity.
6. Remove the cable jacket portion from the cable.

4. CUTTING THE CABLE FILLER (Figure 3)

1. Bend the twisted pairs away from the cable filler.

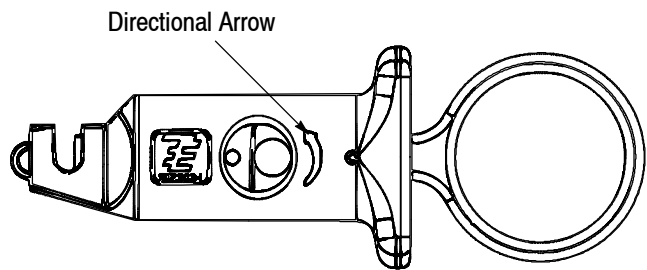
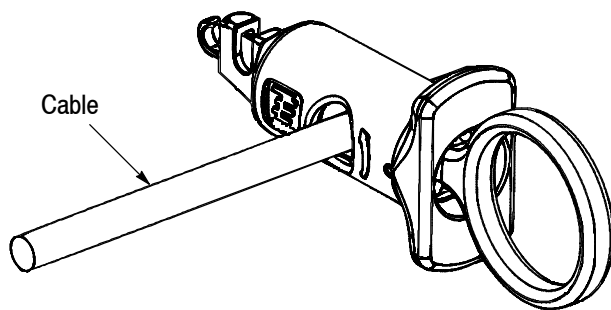



Figure 2

2. To cut the cable filler, place the cable filler into the cable filler shear cavity.
3. Depress the plunger using the finger loop and the housing flanges to extend the shear blade and cut the cable filler.

NOTE  To minimize the length of the cable filler after the cut, the cable should be pushed against the housing.

CAUTION  Do not attempt to cut wires or any other object except for cable filler material in the cable filler shear.

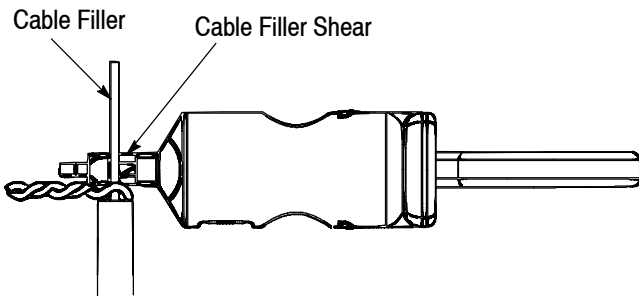

Figure 3

5. UNTWISTING TWISTED WIRE PAIRS (Figures 4 & 5)

1. To untwist a twisted wire pair, depress the plunger using the finger loop and the housing flanges to extend the wire hook.
2. Place the twisted wire pair in the wire hook and release the plunger to clamp the wires. See Figure 4.

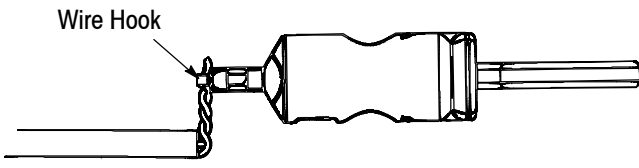



Figure 4

3. Twirl the tool around a finger using the finger loop to untwist the twisted wire pair, as shown in Figure 5.
4. To release the wires from the wire hook, depress the plunger and remove the wires.

NOTE  The JackNack tool can also assist in placing the untwisted wires into the Lacing Fixture (Part Number 1673956-1) of a Tyco Electronics SL Mod Jack Tool (Part Number 1725150-1) before releasing the wires from the wire hook.

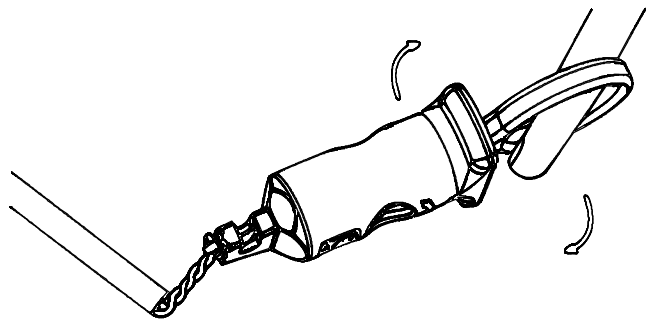



Figure 5

6. REPLACING THE CABLE JACKET STRIPPING BLADE (Figure 6)

DANGER  Care should be taken while handling the cable jacket stripping blade, as it can be very sharp.

1. To remove the old blade, loosen the blade holding screw and remove the blade through the cable jacket stripping cavity.
2. Place the new blade through the cable jacket stripping cavity into the position of the old blade.
3. Replace the blade holding screw.

NOTE  For best performance, the stripping blade should be placed as far as possible toward the wire hook end of the tool before fully tightening the blade holding screw.

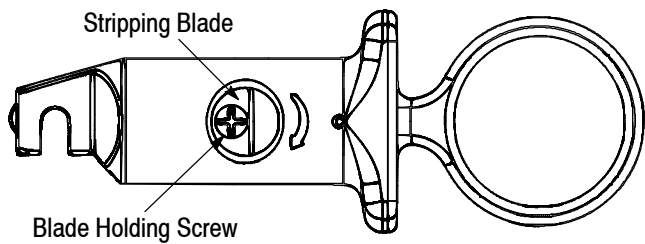

Figure 6

7. ORDERING INFORMATION / REPLACEMENT PARTS

The only part that is replaceable is the cable jacket stripping blade 231674-2. Order this part or additional JackNack tools through your Tyco Electronics Representative, or call 1-800-526-5142, or send a facsimile of your purchase order to 1-717-986-7605, or write to:

CUSTOMER SERVICE (38-35)
 TYCO ELECTRONICS CORPORATION
 P.O. BOX 3608
 HARRISBURG, PA 17105-3608

8. REVISION SUMMARY

- Initial release of document