

## Printed-circuit board connector - MVSTBW 2,5/ 2-ST - 1792524

Please be informed that the data shown in this PDF Document is generated from our Online Catalog. Please find the complete data in the user's documentation. Our General Terms of Use for Downloads are valid (<http://phoenixcontact.com/download>)



Plug component, Nominal current: 12 A, Rated voltage (III/2): 320 V, Number of positions: 2, Pitch: 5 mm, Connection method: Screw connection with tension sleeve, Color: green, Contact surface: Tin

The figure shows a 10-position version of the product

### Product Features

- Well-known connection principle allows worldwide use
- 90° difference in plug-in direction for the conductor connection, reduces the risk of the connector being pulled out with the conductor and narrower conductor routing to the application
- Allows connection of two conductors



### Key Commercial Data

Packing unit	1 pc
GTIN	 4 017918 044954
Weight per Piece (excluding packing)	4.61 g
Custom tariff number	85366990
Country of origin	Germany

### Technical data

#### Dimensions

Width	10 mm
Pitch	5.00 mm
Dimension a	5 mm

#### General

Range of articles	MVSTBW 2,5/...-ST
Insulating material group	I

## Printed-circuit board connector - MVSTBW 2,5/ 2-ST - 1792524

### Technical data

#### General

Rated surge voltage (III/3)	4 kV
Rated surge voltage (III/2)	4 kV
Rated surge voltage (II/2)	4 kV
Rated voltage (III/3)	250 V
Rated voltage (III/2)	320 V
Rated voltage (II/2)	630 V
Connection in acc. with standard	EN-VDE
Nominal current $I_N$	12 A
Nominal cross section	2.5 mm <sup>2</sup>
Maximum load current	12 A
Insulating material	PA
Flammability rating according to UL 94	V0
Internal cylindrical gage	A3
Stripping length	7 mm
Number of positions	2
Screw thread	M3
Tightening torque, min	0.5 Nm
Tightening torque max	0.6 Nm

#### Connection data

Conductor cross section solid min.	0.2 mm <sup>2</sup>
Conductor cross section solid max.	2.5 mm <sup>2</sup>
Conductor cross section flexible min.	0.2 mm <sup>2</sup>
Conductor cross section flexible max.	2.5 mm <sup>2</sup>
Conductor cross section flexible, with ferrule without plastic sleeve min.	0.25 mm <sup>2</sup>
Conductor cross section flexible, with ferrule without plastic sleeve max.	2.5 mm <sup>2</sup>
Conductor cross section flexible, with ferrule with plastic sleeve min.	0.25 mm <sup>2</sup>
Conductor cross section flexible, with ferrule with plastic sleeve max.	2.5 mm <sup>2</sup>
Conductor cross section AWG min.	24
Conductor cross section AWG max.	12
2 conductors with same cross section, solid min.	0.2 mm <sup>2</sup>
2 conductors with same cross section, solid max.	1 mm <sup>2</sup>
2 conductors with same cross section, stranded min.	0.2 mm <sup>2</sup>
2 conductors with same cross section, stranded max.	1.5 mm <sup>2</sup>
2 conductors with same cross section, stranded, ferrules without plastic sleeve, min.	0.25 mm <sup>2</sup>
2 conductors with same cross section, stranded, ferrules without plastic sleeve, max.	1 mm <sup>2</sup>

# Printed-circuit board connector - MVSTBW 2,5/ 2-ST - 1792524

## Technical data

### Connection data

2 conductors with same cross section, stranded, TWIN ferrules with plastic sleeve, min.	0.5 mm <sup>2</sup>
2 conductors with same cross section, stranded, TWIN ferrules with plastic sleeve, max.	1.5 mm <sup>2</sup>
Minimum AWG according to UL/CUL	30
Maximum AWG according to UL/CUL	12

### Standards and Regulations

Connection in acc. with standard	EN-VDE
	CSA
Flammability rating according to UL 94	V0

## Classifications

### eCl@ss

eCl@ss 4.0	272607xx
eCl@ss 4.1	27260701
eCl@ss 5.0	27260701
eCl@ss 5.1	27260701
eCl@ss 6.0	27260704
eCl@ss 7.0	27440402
eCl@ss 8.0	27440309

### ETIM

ETIM 3.0	EC001121
ETIM 4.0	EC002638
ETIM 5.0	EC002638

### UNSPSC

UNSPSC 6.01	30211810
UNSPSC 7.0901	39121409
UNSPSC 11	39121409
UNSPSC 12.01	39121409
UNSPSC 13.2	39121409

## Approvals

### Approvals

# Printed-circuit board connector - MVSTBW 2,5/ 2-ST - 1792524

## Approvals

### Approvals

UL Recognized / VDE Gutachten mit Fertigungsüberwachung / cUL Recognized / IECCE CB Scheme / CSA / EAC / cULus Recognized

---

### Ex Approvals

---

### Approvals submitted

---

## Approval details

UL Recognized 		
	B	D
mm <sup>2</sup> /AWG/kcmil	30-12	30-12
Nominal current I <sub>N</sub>	15 A	10 A
Nominal voltage U <sub>N</sub>	300 V	300 V

VDE Gutachten mit Fertigungsüberwachung 	
mm <sup>2</sup> /AWG/kcmil	0.2-2.5
Nominal current I <sub>N</sub>	12 A
Nominal voltage U <sub>N</sub>	250 V

cUL Recognized 		
	B	D
mm <sup>2</sup> /AWG/kcmil	30-12	30-12
Nominal current I <sub>N</sub>	15 A	10 A
Nominal voltage U <sub>N</sub>	300 V	300 V

# Printed-circuit board connector - MVSTBW 2,5/ 2-ST - 1792524

## Approvals

IECEE CB Scheme	
mm <sup>2</sup> /AWG/kcmil	0.2-2.5
Nominal current I <sub>N</sub>	12 A
Nominal voltage U <sub>N</sub>	250 V

CSA		
	B	D
mm <sup>2</sup> /AWG/kcmil	28-12	28-12
Nominal current I <sub>N</sub>	10 A	10 A
Nominal voltage U <sub>N</sub>	300 V	300 V

EAC

cULus Recognized

## Drawings

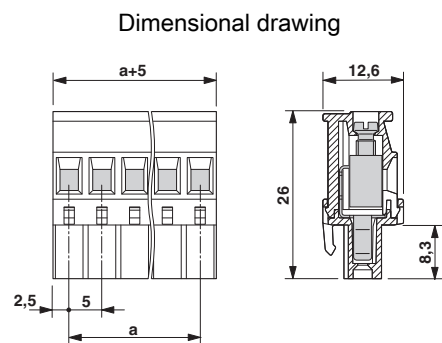
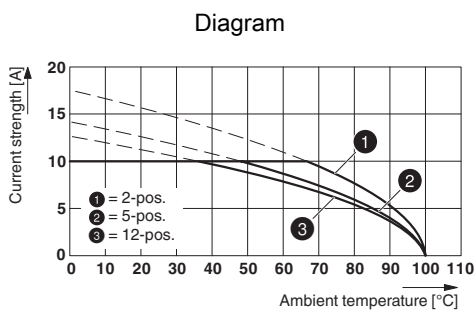

Type: MVSTB(R/W) 2,5/...-ST with MDSTBW 2,5/...-G