

Housing - HC-B 32-TFQ-80/M1PG21S - 1775651

Please be informed that the data shown in this PDF Document is generated from our Online Catalog. Please find the complete data in the user's documentation. Our General Terms of Use for Downloads are valid (<http://phoenixcontact.com/download>)



Sleeve housing, for double locking latch, height 80 mm, with screw connection, 1x Pg21, lateral cable entry

RoHS

Key Commercial Data

Packing unit	1 pc
Minimum order quantity	10 pc
GTIN	 4 017918 038229
GTIN	4017918038229
Weight per Piece (excluding packing)	459.610 g
Custom tariff number	85389099
Country of origin	Germany

Technical data

Dimensions

Height	80 mm
Width	79 mm
Length	94 mm
Wrench size, union nut	28 mm
External cable diameter	10 mm ... 19 mm

Ambient conditions

Degree of protection (IP)	IP65
Ambient temperature (operation)	-40 °C ... 125 °C

General

Housing - HC-B 32-TFQ-80/M1PG21S - 1775651

Technical data

General

Note	For contact inserts HC-B32, DD144, M
Size	B32
Housing type	Sleeve housing
Color	gray aluminum
Locking type	for double locking latch
No. of cable outlets	1
Cable outlet	lateral
Screw connection	with
Type of the screw connection	1x Pg21
Housing material	Aluminum die-cast
Housing surface material	Powder-coated, gray
Cable gland material	Nickel-plated brass
Cable seal material	NBR

Environmental Product Compliance

China RoHS	Environmentally friendly use period: unlimited = EFUP-e
	No hazardous substances above threshold values

Drawings

Dimensional drawing

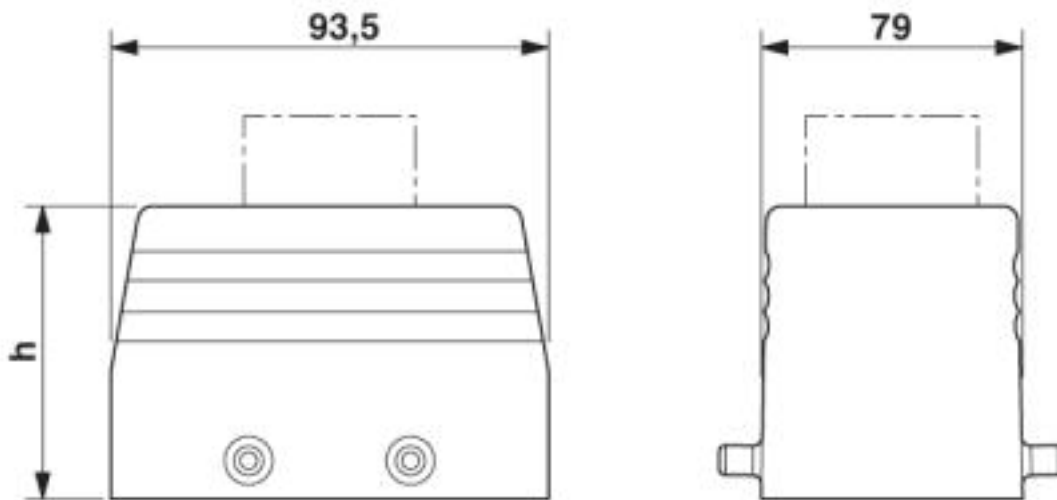

Dimensional drawing

Housing - HC-B 32-TFQ-80/M1PG21S - 1775651

Classifications

eCl@ss

eCl@ss 10.0.1	27440202
eCl@ss 4.0	27140800
eCl@ss 4.1	27140800
eCl@ss 5.0	27143400
eCl@ss 5.1	27261200
eCl@ss 6.0	27261200
eCl@ss 7.0	27440202
eCl@ss 8.0	27440202
eCl@ss 9.0	27440202

ETIM

ETIM 2.0	EC000437
ETIM 3.0	EC000437
ETIM 4.0	EC000437
ETIM 5.0	EC000437
ETIM 6.0	EC000437
ETIM 7.0	EC000437

UNSPSC

UNSPSC 6.01	31261502
UNSPSC 7.0901	31261502
UNSPSC 11	31261502
UNSPSC 12.01	31261502
UNSPSC 13.2	31261501

Approvals

Approvals

Approvals

EAC

Ex Approvals

Approval details

Housing - HC-B 32-TFQ-80/M1PG21S - 1775651

Approvals

EAC



RU C-
DE.AI30.B.01102