

SERPAC 1729V (exploded isometric)

Electronic Enclosures

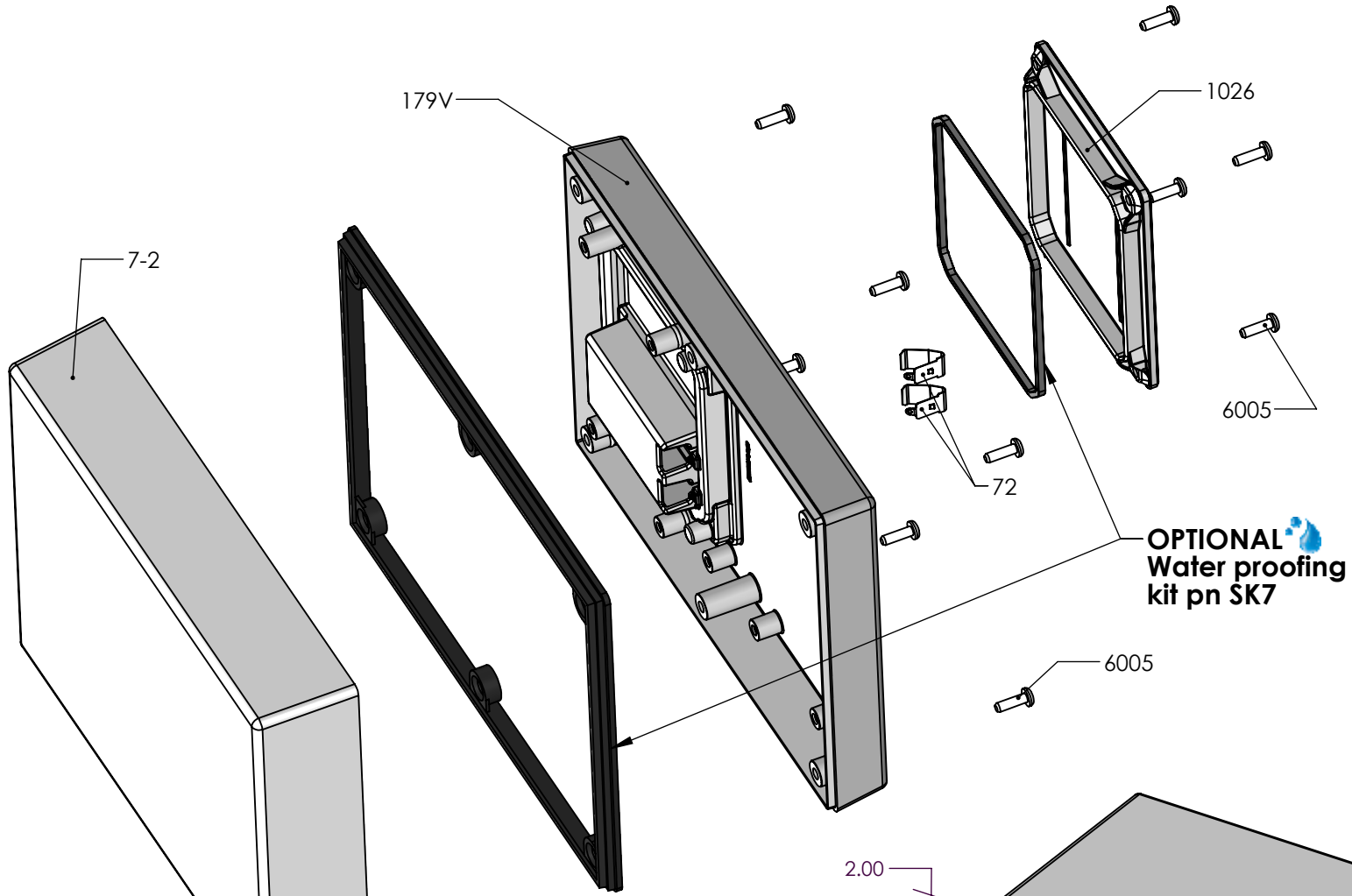

OPTIONAL
Water proofing
kit pn SK7

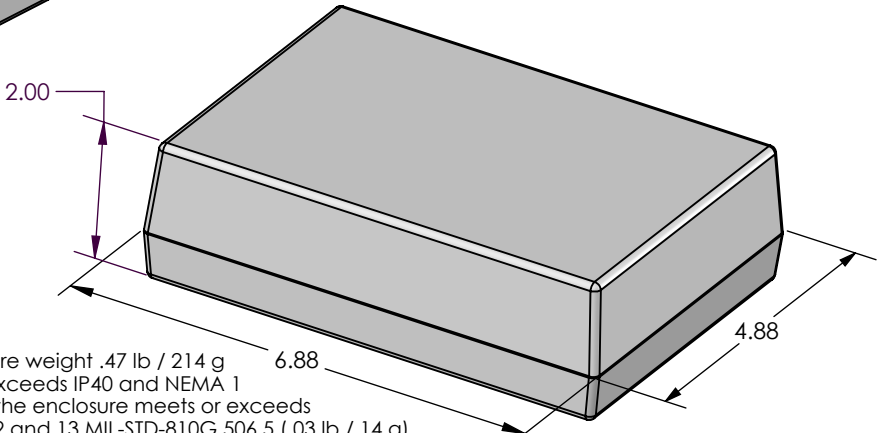

PART NO.	DESCRIPTION (Included)	ACCESSORIES (Optional)
7-2	Top	PART NO. DESCRIPTION
179V	9V Bottom	50 Non-skid Feet
1026	Access Door	SK7 Seal Kit for 17X
6005	#4X3/8" Self-Tapping Screw (10)	
72	Single Battery contact (2)	

- Notes: Enclosure weight .47 lb / 214 g
- 1) Enclosure meets or exceeds IP40 and NEMA 1
 - 2) When used with SK7 the enclosure meets or exceeds IP 67 and NEMA 4X, 12 and 13 MIL-STD-810G 506.5 (.03 lb / 14 g)
 - 3) Circuit Board drawings see sheet 3.
 - 4) All components are RoHS Compliant.

SERPAC 1729V

Electronic Enclosures

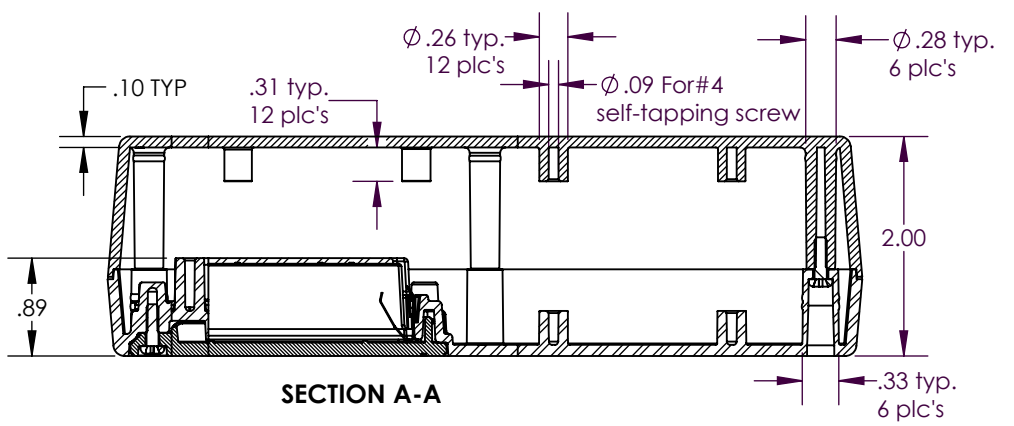
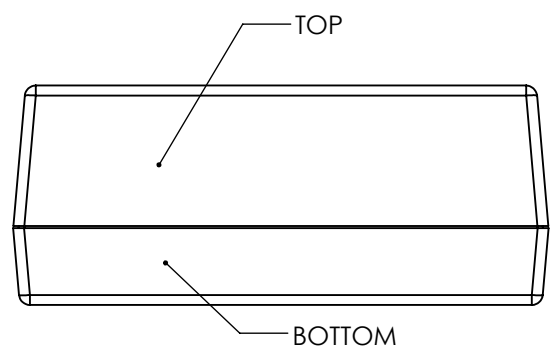
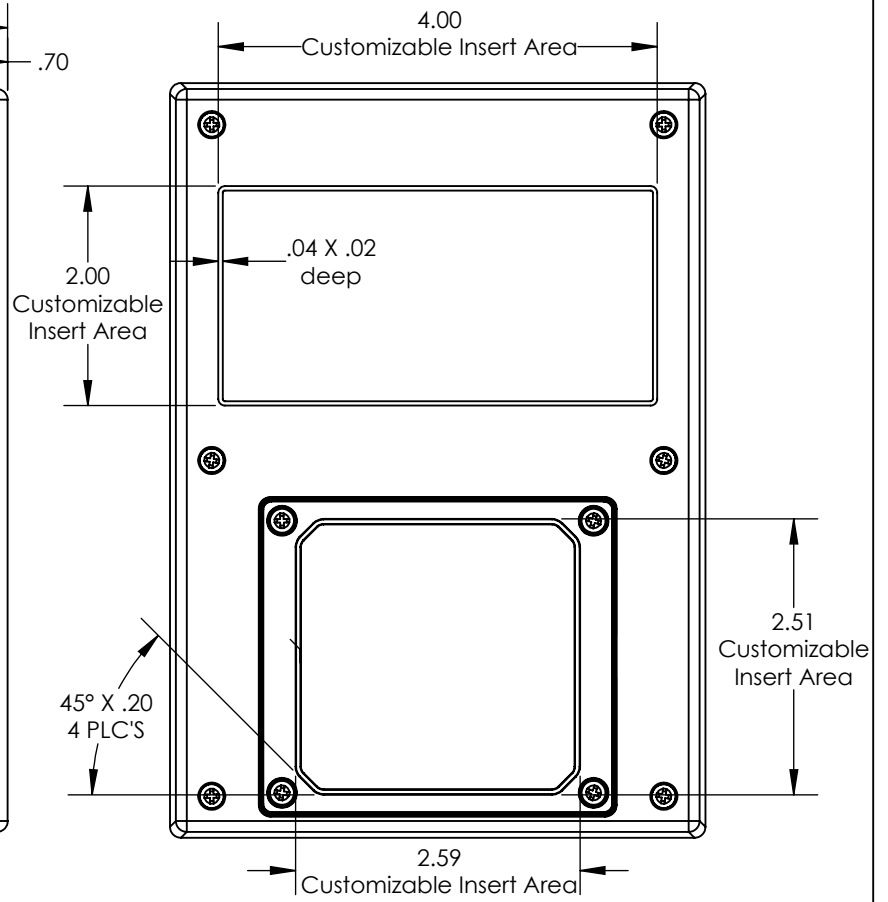
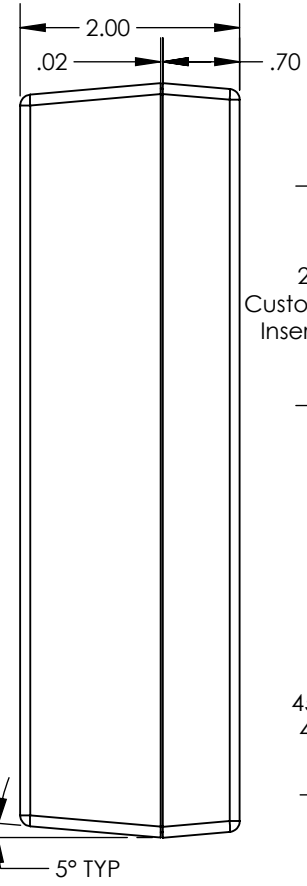
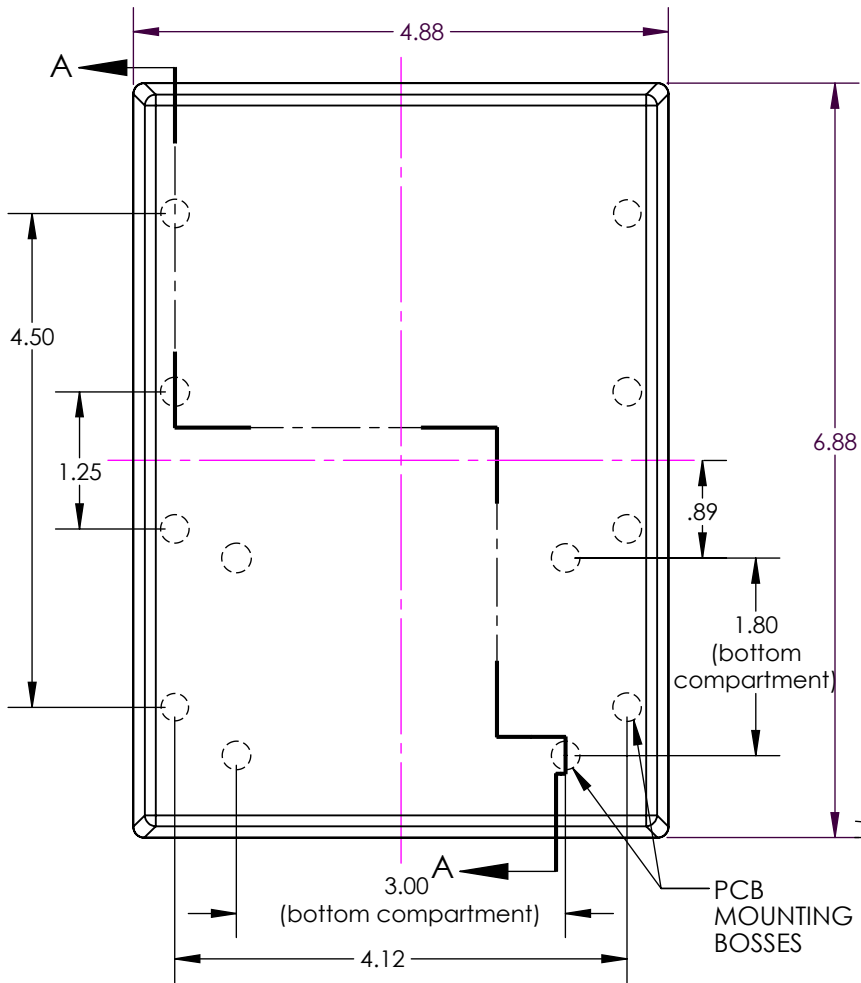

SECTION A-A

SERPAC PCB for 17X compartment enclosures

Electronic Enclosures

CIRCUIT BOARD FOR TOP

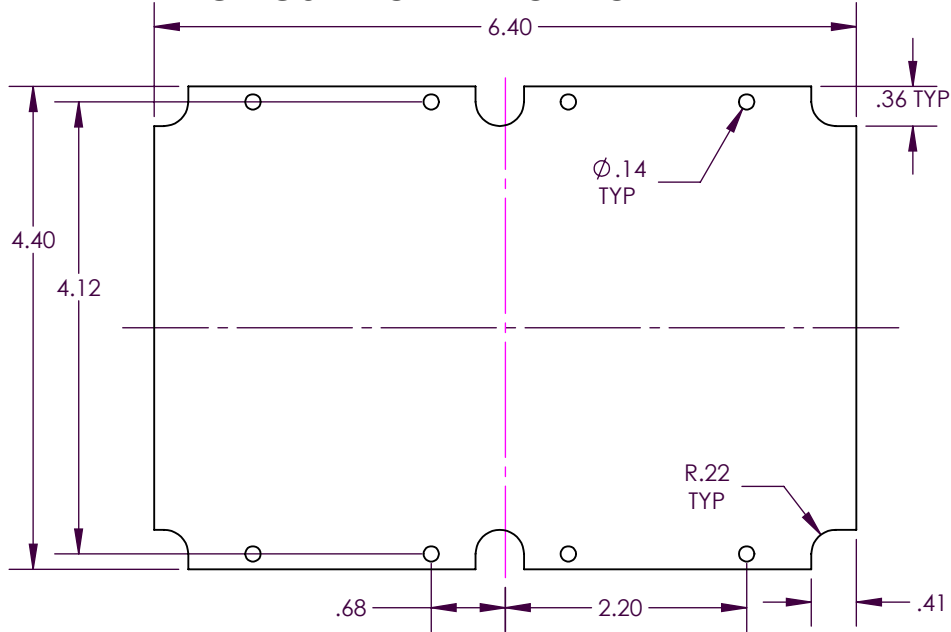

CIRCUIT BOARD FOR BOTTOM

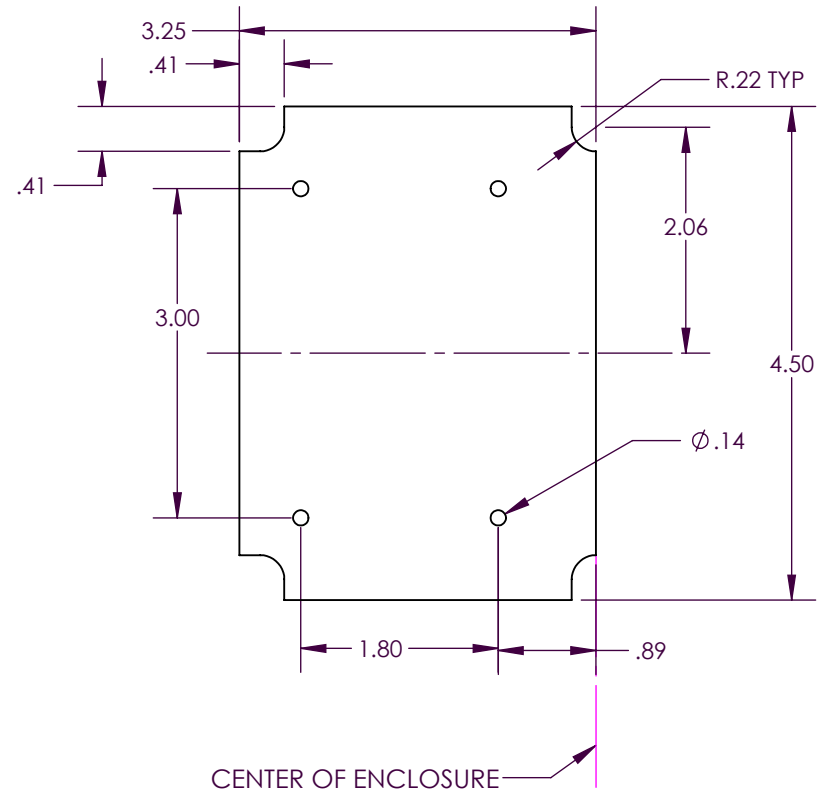

SMALL CIRCUIT BOARD FOR BOTTOM

