



PRECISION COMPRESSION MOUNTING CLAMP SYSTEMS

Wakefield Engineering compression pack heat sinks and clamp systems provide electrical and industrial equipment manufacturers with complete system solutions for proper installation and heat dissipation for high-power compression pack semiconductor. All components for device

mounting and cooling are available separately for all standard compression requirements from 800 lbs (362.9 kg) to 16,000 lbs (7,257.5 kg) force in both natural and forced convection applications.

Clamp Assembly Series	Maximum Clamping Force Force Range	Maximum Diameter (Ref) Power Disc Device	Crossbar Stud Centerline to Centerline Dimension
130 Series	800 lbs (362.9 kg) - 2,000 lbs (907.2 kg)	2.25 in. (57.2 mm)	2.750 in. (69.9 mm) Ref
139 Series	3,000 lbs (1,360.8 kg) and 5,000 lbs (2,268.0 kg)	3.50 in. (88.9 mm)	4.000 in. (101.6 mm) Ref
143 Series	1,000 lbs (453.6 kg) - 6,000 lbs (2,721.6 kg)	3.50 in. (88.9 mm)	4.000 in. (101.6 mm) Ref
144 Series	1,000 lbs (453.6 kg) - 6,000 lbs (2,721.6 kg)	4.00 in. (101.6 mm)	4.625 in. (117.5 mm) Ref
145 Series	2,000 lbs (907.2 kg) - 10,000 lbs (4,535.9 kg)	4.50 in. (114.3 mm)	5.500 in. (139.7 mm) Ref
146 Series	8,000 lbs (3,628.8 kg) - 16,000 lbs (7,257.5 kg)	5.25 in. (133.4 mm)	6.000 in. (152.4 mm) Ref
131/132/133 Series	High-Performance Press Pack Heat Sinks		

These high-quality mounting clamp assemblies are the worldwide standard for mounting, compression, and clamping press-pack SCR, thyristor, rectifier, and other high power disc packaged devices utilized in power distribution equipment, industrial controls, transportation systems, and power supply and conversion systems.

lected (based on maximum clamping force required), will provide the necessary vertical clearance space. For the 130 and 139 Series, this determination is made by subtracting the chosen spring assembly "Z" dimension (refer to dimensional tables) from the crossbar assembly "X" dimension minimum and maximum values, to calculate the available device mounting space clearance for the particular assembly combination. Spring assembly "Z" dimension is the dimension measured from the spring assembly device mounting surface to the spring assembly top surface. Some series have fixed dimensions for alpha characters. All spring assemblies are designed with a force indicator gauge.

Clamp assemblies will accommodate devices with overall case diameters to 5.25 in. (133.4 mm) maximum. Vertical device mounting space available for assemblies is determined by selecting an appropriate series crossbar by length which, when a series spring assembly is selected



130 SERIES Compression Mounting Clamp Assemblies for Semiconductors to 2.25 in. (57.2mm) Diameter

130 SERIES CROSSBAR
800 lb - 2,000 lb (362.8 kg - 907.2 kg)
 Crossbar Device Mounting, Surface to Spring Assembly
 Top Surface Dimension

Model No.	"X" Dimension		Weight lbs. (grams)
	Min. In. (mm)	Max. In. (mm)	
130-A	1.74 (44.2)	2.12 (53.8)	0.4 (181.44)
130-B	2.05 (52.1)	2.43 (61.7)	0.418 (189.60)
130-C	2.36 (59.9)	2.74 (69.6)	0.427 (193.68)
130-D	2.67 (67.8)	3.05 (77.5)	0.437 (198.22)
130-E	2.98 (75.7)	3.36 (85.3)	0.447 (202.76)
130-F	3.29 (83.6)	3.67 (93.2)	0.461 (209.11)
130-G	3.60 (91.4)	3.98 (101.1)	0.476 (215.91)
130-H	3.91 (99.3)	4.29 (109.0)	0.486 (220.45)
130-J	4.22 (107.2)	4.60 (116.8)	0.497 (225.44)
130-K	4.53(115.1)	4.91 (124.7)	0.51 (231.33)
130-L	4.34 (122.9)	5.22 (132.6)	0.52 (235.87)
130-M	5.15 (130.8)	5.53 (140.5)	0.534 (242.22)
130-N	5.46 (138.7)	5.84 (147.3)	0.544 (246.75)
130-P	5.77 (146.6)	6.15 (156.2)	0.559 (253.56)

130 SERIES SPRING ASSEMBLY

Model No.	No. of Leaves	"Z" Dim. in. (mm)	Max Force lb (kg)	Weight lbs (gms)
130-1	2	0.90 (22.9)	2,000 (907.2)	0.331 (150.14)
130-2	2	0.50 (12.7)	800 (362.8)	0.19 (86.18)
130-3	3	0.61 (15.5)	1,200 (544.3)	0.219 (99.34)
130-4	4	0.72 (18.3)	1,600 (727.8)	0.333 (151.05)
130-5	5	0.83 (21.1)	2,000 (907.2)	0.408 (185.07)

Notes:

1. Spring assemblies are stainless steel leaves with a force indicator gauge, except the lowest cost Type 130-1 spring assembly manufactured from automotive grade stainless steel.

Order Guide:
 Order Crossbar and Spring Assembly separately by type number from table.

Dimensions:
 in. (mm)
 lb. (kg)

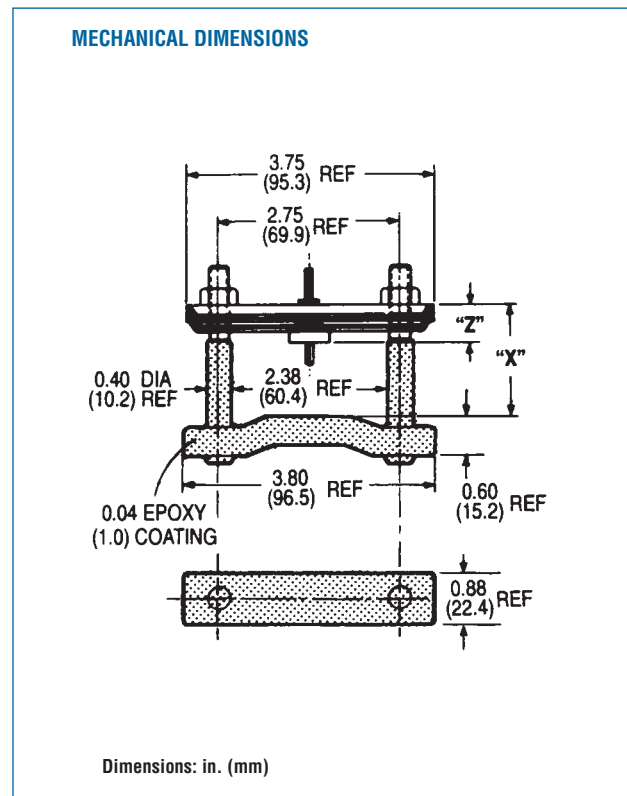

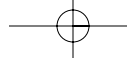

PRECISION COMPRESSION MOUNTING CLAMP SYSTEMS

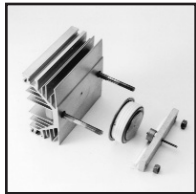

139 SERIES *Compression mounting clamp assemblies for semiconductors to 3.50 in. (88.9 mm) Diameter*

139 SERIES CROSSBAR
3,000 lb - 5,000 lb, (1,360.8 kg - 2,268.0 kg), Crossbar Device Mounting, Surface to Spring Assembly, Top Surface Dimension

139-3 SERIES CROSSBAR - 3,000 LB (1,360.8)				139-5 SERIES CROSSBAR - 5,000 LB (2,268.0)			
Model No.	"X" Dimension		Weight lbs. (grams)	Model No.	"X" Dimension		Weight lbs. (grams)
	Min in. (mm)	Max			Min in. (mm)	Max	
139-3A	1.52 (38.6)	1.89 (48.0)	0.689 (312.52)	139-5A	1.52 (38.6)	1.89 (48.0)	0.94 (426.38)
139-3B	1.83 (46.5)	2.21 (56.1)	0.7 (317.51)	139-5B	1.83 (46.5)	2.21 (56.1)	0.96 (435.45)
139-3C	2.14 (54.4)	2.52 (64.0)	0.706 (320.24)	139-5C	2.14 (54.4)	2.52 (64.0)	0.98 (444.52)
139-3D	2.45 (62.2)	2.83 (71.9)	0.721 (327.04)	139-5D	2.45 (62.2)	2.83 (71.9)	1.01 (458.13)
139-3E	2.77 (70.4)	3.14 (79.8)	0.732 (332.03)	139-5E	2.77 (70.4)	3.14 (79.8)	1.02 (462.66)
139-3F	3.08 (78.2)	3.45 (87.6)	0.741 (336.11)	139-5F	3.08 (78.2)	3.45 (87.6)	1.033 (468.56)
139-3G	3.39 (86.1)	3.77 (95.8)	0.762 (345.64)	139-5G	3.39 (86.1)	3.77 (95.8)	1.053 (477.63)
139-3H	3.70 (94.0)	4.08 (103.6)	0.773 (350.63)	139-5H	3.70 (94.0)	4.08 (103.6)	1.074 (487.64)
130-3J	4.01 (101.9)	4.39 (111.5)	0.784 (355.62)	139-5J	4.33 (101.9)	4.39 (111.5)	1.064 (482.62)
139-3K	4.33 (110.0)	4.70 (119.4)	0.79 (358.34)	139-5K	4.33 (110.0)	4.70 (119.4)	1.075 (487.61)
139-3L	4.64 (117.9)	5.01 (127.3)	0.793 (359.70)	139-5L	4.64 (117.9)	5.01 (127.3)	1.088 (493.51)
139-3M	4.95 (125.7)	5.33 (135.4)	0.796 (361.06)	139-5M	4.95 (125.7)	5.33 (135.4)	1.102 (499.86)
139-3N	5.26 (133.6)	5.64 (143.3)	0.832 (377.39)	139-5N	5.26 (133.6)	5.64 (143.3)	1.11 (503.49)
139-3P	5.57 (141.5)	5.95 (151.1)	0.838 (380.11)	139-5P	5.57 (141.5)	5.95 (151.1)	1.171 (531.16)

CROSSBAR HEIGHT AND WIDTH

Series Number	Height "A" Reference in. (mm)	Width "B" Reference in. (mm)
139-3	0.72 (18.3)	0.95 (24.1)
139-5	1.02 (25.9)	0.83 (21.1)

Order Guide:
 Order Crossbar and Spring Assembly separately by type number from table.

Dimensions:
 in. (mm)
 lb. (kg)

139 SERIES SPRING ASSEMBLY

Model Number	Number of Leaves	"Z" Dimension in. (mm)	Maximum Force lb. (kg)
139-1	1	0.87(22.1)	3,000 (1,360.8)
139-2	2	1.25(31.8)	5,000 (2,268.0)

MECHANICAL DIMENSIONS

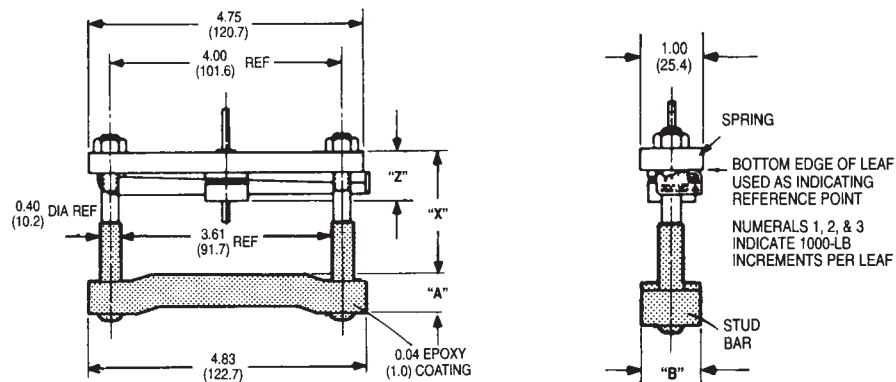

Dimensions: in. (mm)

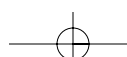



PRECISION COMPRESSION MOUNTING CLAMP SYSTEMS



143 SERIES *Compression Mounting Clamp Assemblies for Semiconductors to 3.50 in (88.9 mm) Diameter*

143 SERIES CROSSBAR
2,000 lb - 6,000 lb (907.2 kg - 2,721.6 kg)

Crossbar Device Mounting, Surface to Spring Assembly, Top Surface Dimension

Model No.	"X" Dimension		Overall Height "H" In. (mm)	Weight lbs. (grams)
	Min	Max		
143-A	1.30 (33.0)	1.80 (45.7)	4.68 (118.9)	1.100 (498.95)
143-B	1.86 (45.7)	2.30 (58.4)	5.18 (131.6)	1.125 (510.29)
143-C	2.30 (58.4)	2.80 (71.1)	5.68 (144.3)	1.150 (521.63)
143-D	2.80 (71.1)	3.30 (83.8)	6.18 (157.0)	1.175 (532.97)
143-E	3.30 (83.8)	3.80 (96.5)	6.68 (169.7)	1.200 (544.31)
143-F	3.80 (96.5)	4.30 (109.2)	7.18 (182.4)	1.225 (555.65)
143-G	4.30 (109.2)	4.80 (121.9)	1.68 (195.1)	1.250 (566.99)
143-H	4.80 (121.9)	5.30 (134.6)	8.18 (207.8)	1.275 (578.33)
143-J	5.30 (134.6)	5.80 (147.3)	8.68 (220.5)	1.300 (589.67)
143-K	5.80 (147.3)	6.30 (160.0)	9.18 (233.2)	1.325 (601.00)
143-L	6.30 (160.0)	6.80 (172.7)	9.68 (245.9)	1.350 (612.35)

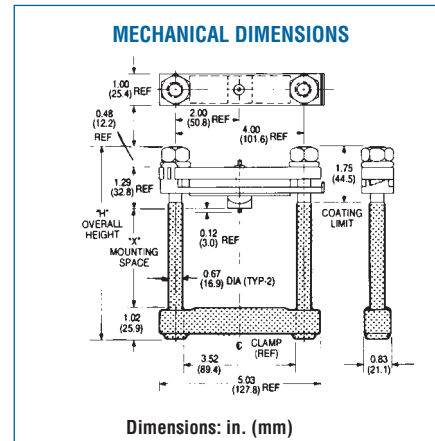

143 SERIES SPRING ASSEMBLY

Model Number	Number of Leaves	Max. Clamping Force lb. (kg)	Weight lb. (grams)
143-2	2	6,000 (2,721.6)	0.813 (368.77)

Order Guide:
Order Crossbar and Spring Assembly separately by type number from table.

Dimensions:
in. (mm)
lb. (kg)



144 SERIES *Compression Mounting Clamp Assemblies for Semiconductors to 4.00 in (101.6mm) Diameter*

144 SERIES CROSSBAR
1,000 lb - 6,000 lb (453.6 kg - 2,721.6 kg)

Crossbar Device Mounting, Surface to Spring Assembly
Top Surface Dimension

Model No.	"X" Dimension		Weight lbs (grams)
	Min	Max	
144-A	1.50 (38.1)	2.00 (50.8)	1.231 (558.37)
144-B	2.00 (50.8)	2.50 (63.5)	1.262 (572.43)
144-C	2.50 (63.5)	3.00 (63.5)	1.285 (582.87)
144-D	3.00 (76.2)	3.50 (88.9)	1.310 (594.21)
144-E	3.50 (88.9)	4.00 (101.6)	1.352 (613.26)

144 SERIES SPRING ASSEMBLY

Model No.	Clamping Force Range lb (kg)	Weight lbs (grams)
144-2	1,000 (453.6) - 6,000 (2,721)	1.772 (803.77)

Order Guide:
Order Crossbar and Spring Assembly separately by type number from table.

Dimensions:
in. (mm)
lb. (kg)

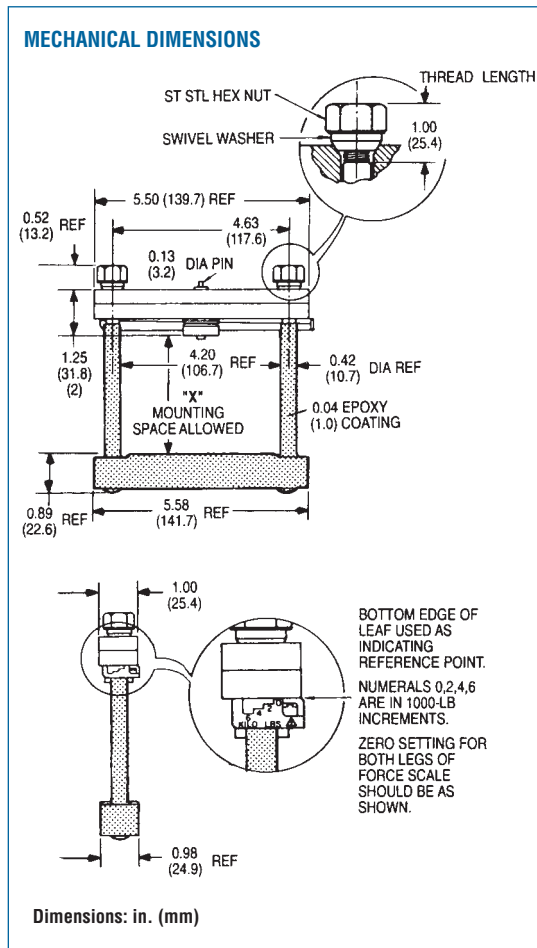

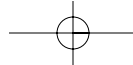

Precision Compression Clamp Systems



PRECISION COMPRESSION MOUNTING CLAMP SYSTEMS



145 SERIES

Compression Mounting Clamp Assemblies for Semiconductors to 4.50 in (114.3 mm) Diameter

145 SERIES CROSSBAR
2,000 lb - 10,000 lb (907.2 kg - 4,535.9 kg)

Crossbar Device Mounting, Surface to Spring Assembly, Top Surface Dimension

Model No.	"X" Dimension		Overall Height "H" In. (mm)	Weight lbs. (grams)
	Min In. (mm)	Max In. (mm)		
145-A	1.75 (44.5)	2.50 (63.5)	6.00 (152.4)	3.845 (1744.06)
145-B	2.50 (63.5)	3.25 (82.6)	6.75 (171.5)	3.987 (1808.47)
145-C	3.25 (82.6)	4.00 (101.6)	7.50 (190.5)	4.06 (1841.58)
145-D	4.00 (101.6)	4.75 (120.7)	8.25 (209.6)	4.187 (1899.19)
145-E	4.75 (120.7)	5.50 (139.7)	9.00 (228.6)	4.37 (1982.20)
145-F	5.50 (139.7)	6.25 (158.8)	9.75 (247.7)	4.459 (2022.57)

145 SERIES SPRING ASSEMBLY

Model No.	Clamping Force Range lb (kg)	Weight lbs (grams)

Order Guide:

Order Crossbar and Spring Assembly separately by type number from table.

Dimensions:

in. (mm)
lb. (kg)

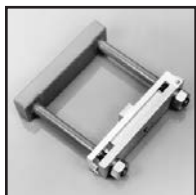
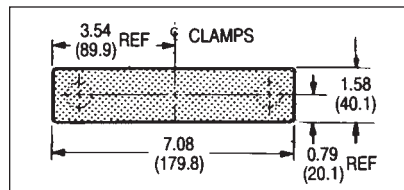
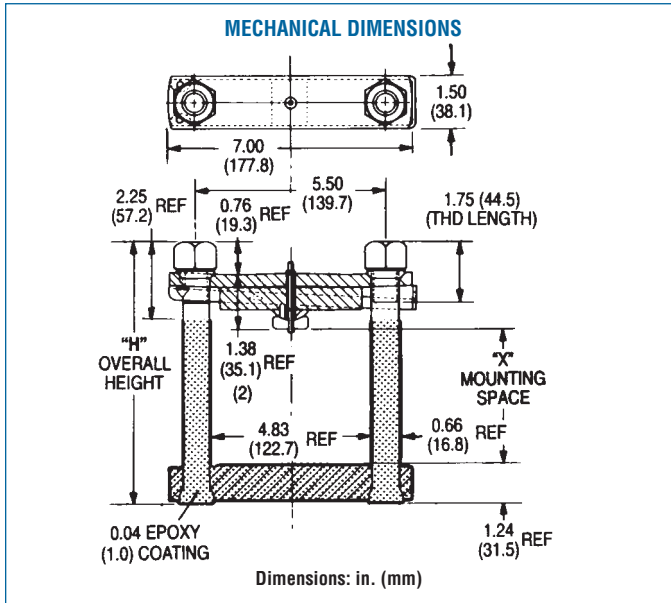

146 SERIES

Compression Mounting Clamp Assemblies for Semiconductors to 5.25 in (133.5 mm) Diameter

146 SERIES CROSSBAR
8,000 lb - 16,000 lb (3,628.7 kg - 7,257.4 kg)

Crossbar Device Mounting, Surface to Spring Assembly, Top Surface Dimension

Model No.	"X" Dimension		Overall Height "H" In. (mm)	Weight lbs. (grams)
	Min In. (mm)	Max In. (mm)		
146-A	1.54 (39.1)	2.29 (58.2)	5.92 (150.4)	3.813 (1729.55)
146-B	2.29 (58.2)	3.04 (77.2)	6.67 (169.4)	3.938 (1786.25)
146-C	3.04 (77.2)	3.79 (96.3)	7.42 (188.5)	4.063 (1842.95)
146-D	3.79 (96.3)	4.54 (115.3)	8.17 (207.5)	4.188 (1899.64)
146-E	4.54 (115.3)	5.29 (134.4)	8.92 (226.6)	4.313 (1956.34)
146-F	5.29 (134.4)	6.04 (153.4)	9.67 (245.6)	4.438 (2013.04)
146-G	6.04 (153.4)	6.79 (172.5)	10.42 (264.7)	4.563 (2069.74)

146 SERIES SPRING ASSEMBLY

Model Number	Number of Leaves	Clamping Force Range lb (kg)	Maximum Force lb (grams)
146-2	2	8,000 (3,628.7) - 16,000 (7,257.5)	2,688 (1,219.26)

Order Guide:

Order Crossbar and Spring Assembly separately by type number from table.

Dimensions:

in. (mm)
lb. (kg)

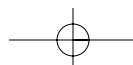
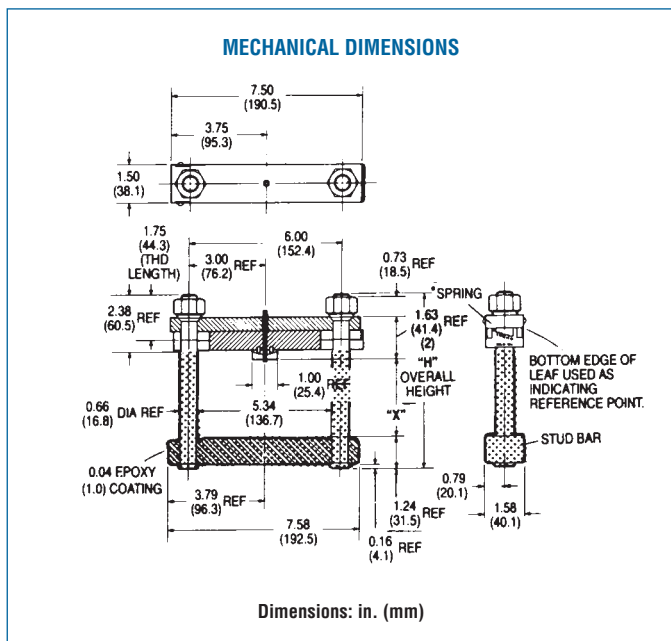



132/133 SERIES HIGH-PERFORMANCE HEAT SINKS FOR COMPRESSION TYPE DEVICES

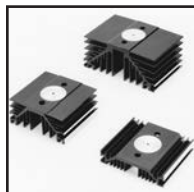

132/133 SERIES

Dimensions: in.(mm)
Finish: B = Black Anodized
 G = Gold Iridite
Material: Aluminum Alloy

Standard P/N		Nominal Dimensions: (1)			Clamp System Series(5)	Thermal Performance at Typical Load (2)	
Black Anodize(4,5)	Gold Iridite	Width in. (mm)	Length "A" in. (mm)	Height in. (mm)		Natural Convection (°C/W)(3)	Convection (°C/W) @ 500 LFM
132-4.5B	132-4.5G	5.000 (127.0)	4.500 (114.3)	2.250 (57.2)	130	0.61	0.170
132-10B	132-10G	5.000 (127.0)	10.000 (254.0)	2.250 (57.2)	130	0.38	0.130
132-15.5B	132-15.5G	5.000 (127.0)	15.500 (393.7)	2.250 (57.2)	130	0.28	0.100
132-5-B9	132-5-G9	5.000 (127.0)	5.000 (127.0)	2.250 (57.2)	139	0.61	0.170
132-11-B9	132-11-G9	5.000 (127.0)	11.000 (299.4)	2.250 (57.2)	139	0.37	0.120
133-4.5B	133-4.5G	7.000 (139.2)	4.500 (114.3)	3.125 (79.4)	130	0.37	0.110
133-7.5B	133-7.5G	7.000 (139.2)	7.500 (190.5)	3.125 (79.4)	130	0.28	0.085
133-10B	133-10G	7.000 (139.2)	10.000 (254.0)	3.125 (79.4)	130	0.26	0.082
133-5-B9	133-5-G9	7.000 (139.2)	5.000 (127.0)	3.125 (79.4)	139	0.37	0.110
133-7.5-B9	133-7.5-G9	7.000 (139.2)	7.500 (190.5)	3.125 (79.4)	139	0.28	0.085
133-11-B9	133-11-G9	7.000 (139.2)	11.000 (279.4)	3.125 (79.4)	139	0.24	0.076

MULTIPLE ASSEMBLY CONFIGURATION

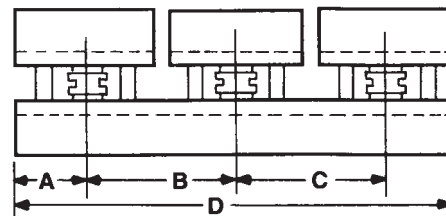

Type	Use with	A	B	C	D
132-4.5	-	-	-	-	See Fig.132
132-10	2 ea 132-4.5	2.25	5.50	-	10.0
132-15.5	3 ea 132-4.5	2.25	5.50	5.50	15.5
133-4.5	-	-	-	-	See Fig.133
133-7.5	-	-	-	-	See Fig.133
133-10	2 ea 133-4.5	2.25	5.50	-	10.0
132-5-9**	-	-	-	-	See Fig.132
132-11-9**	2 ea 132-5-9	2.50	6.00	-	11.00
133-5-9**	-	-	-	-	See Fig. 133
133-7.5-9**	-	-	-	-	See Fig. 133
133-11-9**	2 ea 133-5-9	2.50	6.00	-	11.00

Notes:

- Nominal dimensions for one heat sink of this type.
- Thermal performance values shown are per pair of heat sinks.
- Natural convection performance at 50°C heat sink rise above ambient.
- Black anodize finish [1.875 in. (47.6 mm) diameter spot face. Device mounting surface area free of finish].
- Predrilled heat sinks accept 130 and 139 Series clamp systems.

** -9 indicates heat sinks drilled for 139 clamp.

132 SERIES NATURAL AND FORCED CONVECTION CHARACTERISTICS

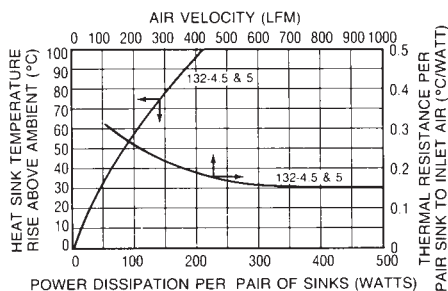

MECHANICAL DIMENSIONS (EXTRUSION PROFILE 3560-2)

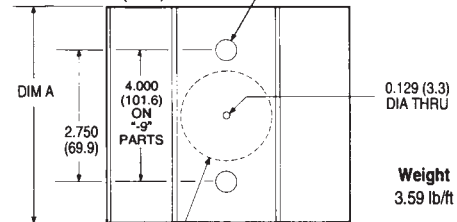
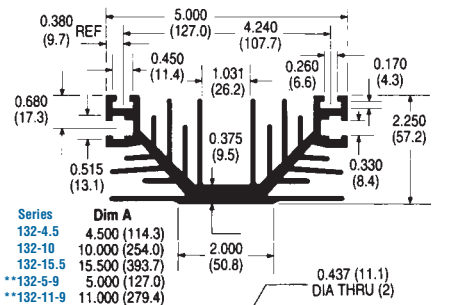

*1.875 (47.6) DIA MACHINED FLAT WITHIN 0.0015 (0.04) TIR FREE OF FINISH ON BLACK ANODIZE PARTS ONLY
 **SURFACES FREE OF FINISH ON "B" PARTS
 **4.000 (101.6) ON "-9" PARTS

Dimensions: in. (mm)

133 SERIES NATURAL AND FORCED CONVECTION CHARACTERISTICS

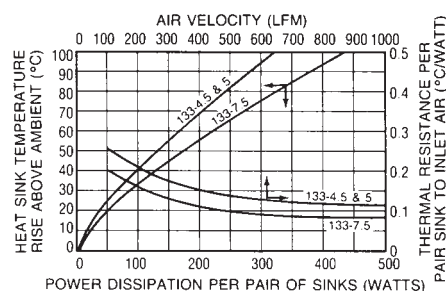

MECHANICAL DIMENSIONS (EXTRUSION PROFILE 3559-2)

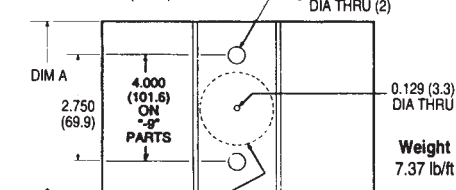
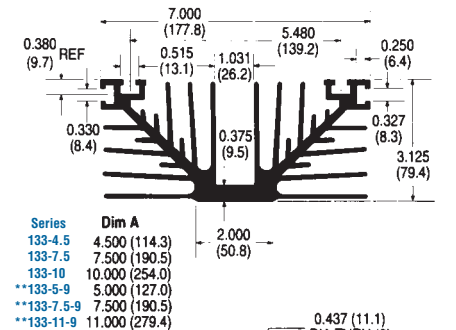

*1.875 (47.6) DIA MACHINED FLAT WITHIN 0.0015 (0.04) TIR FREE OF FINISH ON BLACK ANODIZE PARTS ONLY
 **SURFACES FREE OF FINISH ON "B" PARTS
 **4.000 (101.6) ON "-9" PARTS