

ROLLER LEVER MAY BE ADJUSTED FOR AN INFINITE NUMBER OF POSITIONS THRU 360°. ADJUSTMENT IS MADE BY LOOSENING THE LOCK NUT AND THEN THE LOCKSCREW AND TURNING GEAR UNTIL LEVER IS IN DESIRED POSITION. SCREW AND LOCK NUT ON SHAFT IS THEN TIGHTENED TO POSITIVELY LOCK LEVER IN POSITION

LEVER ADJUSTMENT DETAIL SCALE 2:1

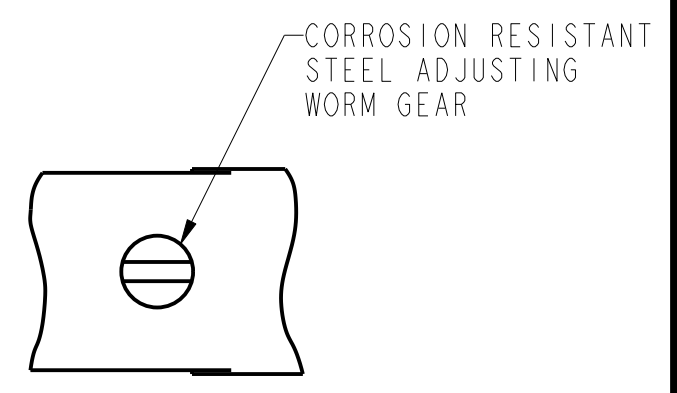
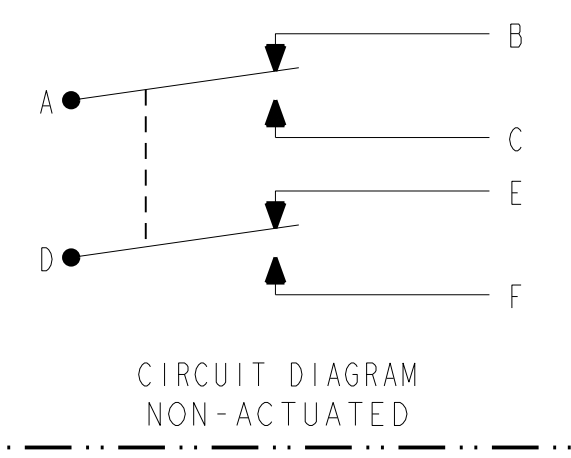

VIEW A-A SCALE 2:1

NOTES

- 1 - NOTED ELECTRICAL RATING APPLY AS SPECIFIED IN MIL-PRF-8805/40-1 UP TO 185°F
- 2 - SWITCH SEALED PER MIL-PRF-8805, SYMBOL 4
- 3 CORROSION RESISTANT STEEL SHAFT, BUSHING AND PINS
- 4 DO NOT APPLY MORE THAN 20-25 INCH-POUNDS OF TORQUE WHEN TIGHTENING LOCKING NUT
- 5 - CIRCUIT DIAGRAM, CAT LISTING, AND FCSM NO. ARE MARKED ON SWITCH
- 6 HARDWARE MAY BE PACKAGED UNASSEMBLED PER MIL-PRF-8805
- 7 - REPLACEMENT MOUNTING HARDWARE - PACKET 19PA10
- 8 .050 WIDE X .050 DEEP SLOT
- 9 Ø.037 HOLE FOR WIRE LOCKING

(Ø.750) X .31 WIDE LAMINATED PHENOLIC ROLLER

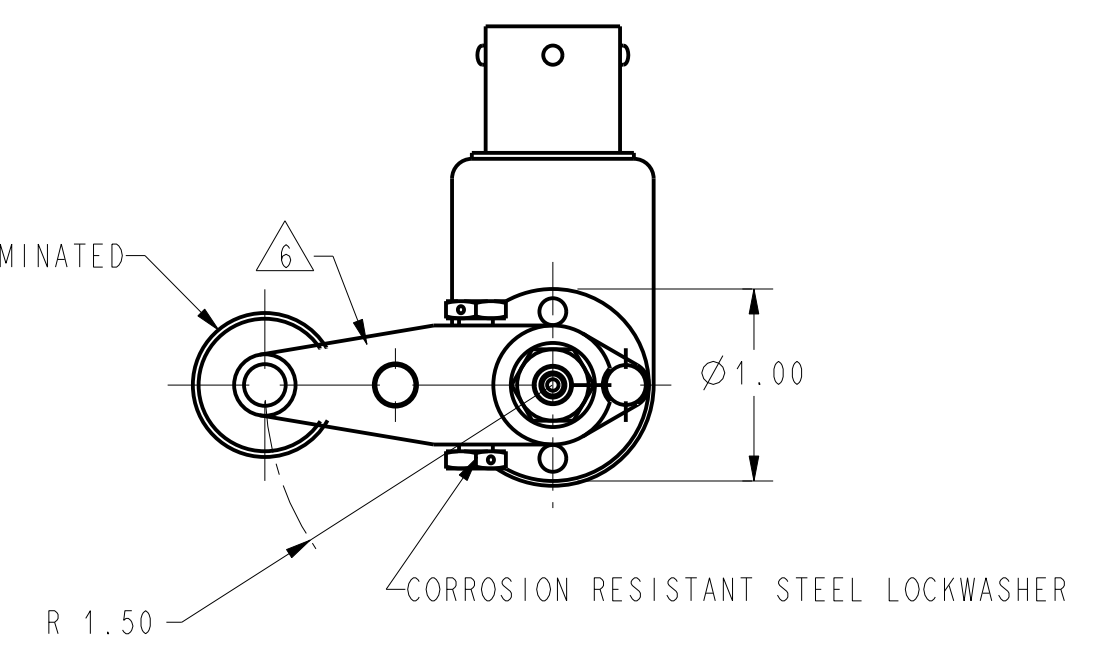

CORROSION RESISTANT LOCKING NUT, .37 ACROSS FLATS (MS 21083-C3) 6/4

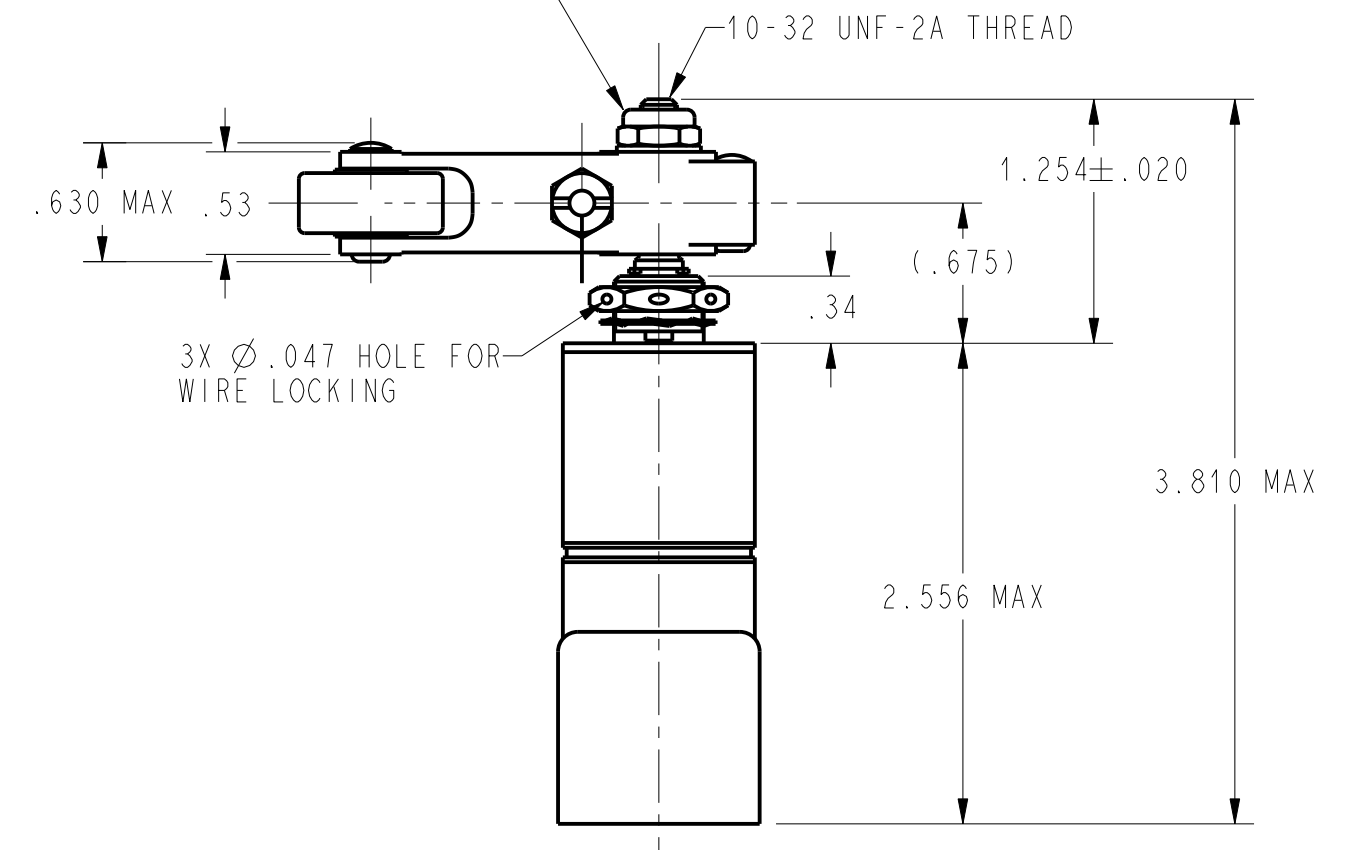

- CORROSION RESISTANT STEEL WASHER Ø.438 X .032 THICK (AN960-C10L) 6
- 15/32-32 UNS-2A THREAD TO WITHIN .062 OF SHOULDER
- CORROSION RESISTANT STEEL HEX NUT .62 ACROSS FLATS X .125 THICK (MS21340-04) 6
- CORROSION RESISTANT STEEL INTERNAL TOOTH LOCKWASHER, Ø.59 X (.018) THICK (MS35333-121) 6
- 2X Ø.140 X .062 HIGH PINS LOCATED ON Ø.765 CENTER

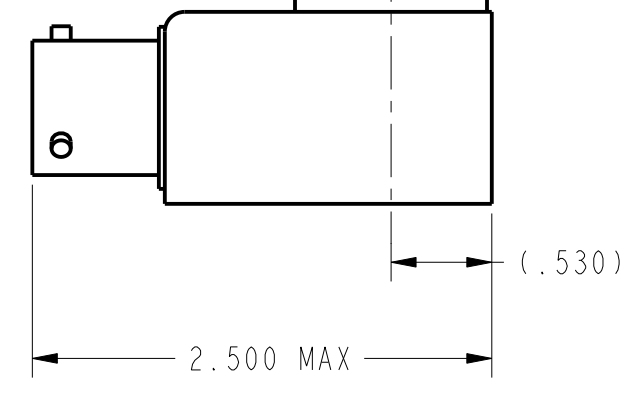
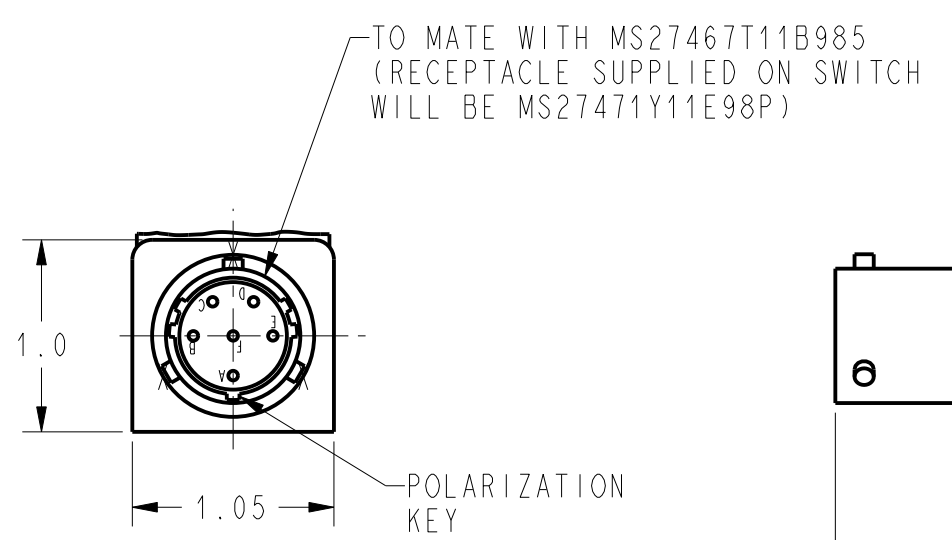

131EN92-R
 DRAWING NUMBER
 ISSUE 6
 PAGES 1 OF 1
 RELEASE NO. PR-21908
 CHECKED
 DRAWN
 P.T.C./CAD 20
 D.L.T. 25 JUN 02
 SAV 25 JUN 02
 CHECKED
 SAV 25 JUN 02

CHARACTERISTICS		ELECTRICAL DATA	
OPERATING TORQUE	12-25 IN LB	CONTACT ARRANGEMENT 2X S P D T (SEE CIRCUIT DIAGRAM)	
RELEASE TORQUE	9 IN LB MIN	LOAD	28 VDC
PRETRAVEL			SEA LEVEL
DIFFERENTIAL TRAVEL		RES	4
OVERTRAVEL		IND	2
FREE POSITION		MOTOR	4

ANSI Y14.5M-1982 APPLIES

THIS DRAWING COVERS A PROPRIETARY ITEM AND IS THE PROPERTY OF MICRO SWITCH, A DIVISION OF HONEYWELL. THIS DRAWING IS NOT TO BE COPIED OR USED WITHOUT THE APPROVAL OF MICRO SWITCH.

MICRO SWITCH
a Honeywell Division

SWITCH - ENCLOSED

CATALOG LISTING
131EN92-R

THIRD ANGLE PROJECTION

SCALE FULL

DO NOT SCALE PRINT

UNLESS OTHERWISE SPECIFIED TOLERANCES ARE

ONE PLACE	(.0)	±.030
TWO PLACES	(.00)	±.015
THREE PLACES	(.000)	±.005
ANGLES		±

WEIGHT 12.0 OZ MAX