

MM 3-D MODEL: TM-111112-1001

HEATSINK SPRING CLIP

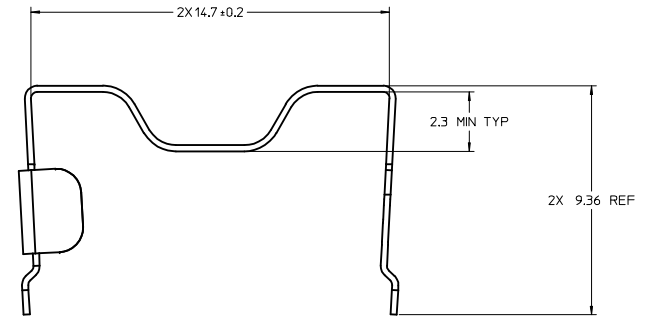
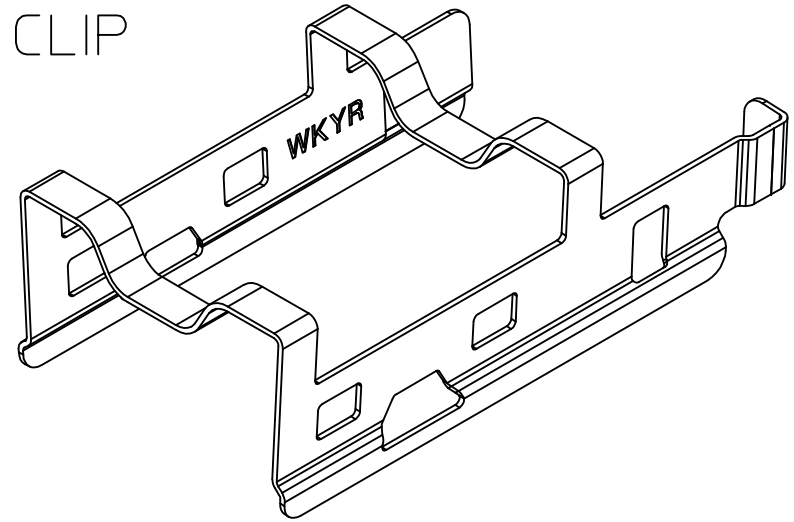
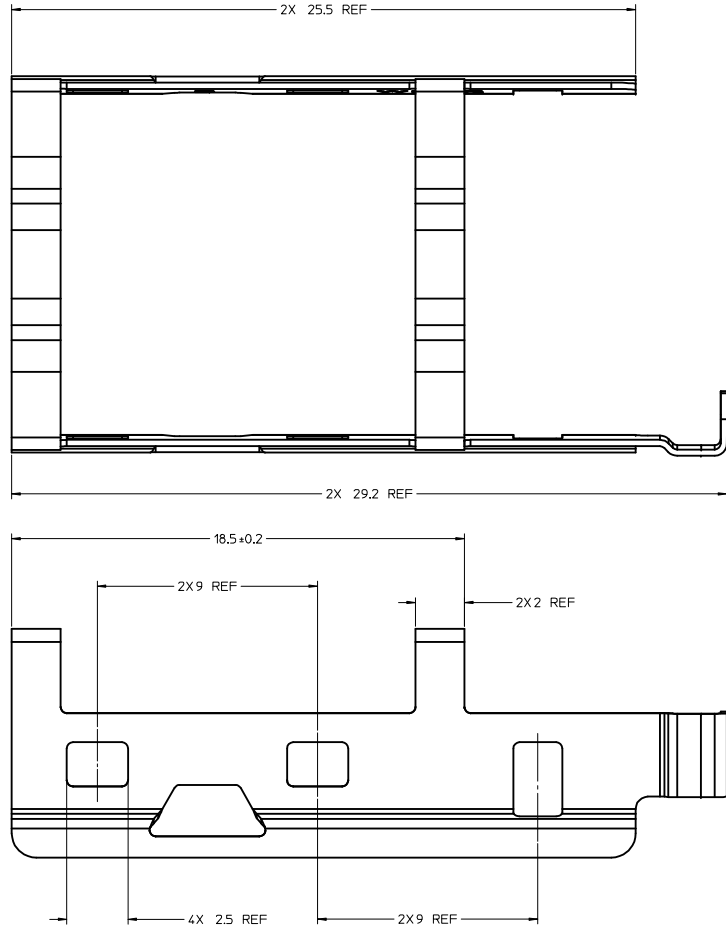

- NOTES:**
1. MATERIAL: STAINLESS STEEL
 2. NO RoHS EXEMPTIONS
 3. THE MOLEX HEATSINK SPRING CLIP CAN ONLY BE USED ON MOLEX CAGES

REV	DESCRIPTION	QUALITY SYMBOLS	GENERAL TOLERANCES (UNLESS SPECIFIED)		DIMENSION STYLE	SCALE	DESIGN UNITS	THIRD ANGLE PROJECTION
			mm	INCH				
4	PLACES	+	---	+	MM ONLY	10:1	METRIC	SFP/SFP+ 1X1 CAGE ACCESSORIES HEATSINK AND CLIP molex DOCUMENT NO. SD-111112-1001 SHEET NO. 1 OF 3
3	PLACES	+	---	+	DATE	2010/04/23	DATE	
2	PLACES	+	0.13	+	DATE	2010/04/23	DATE	
1	PLACE	+	0.25	+	DATE	2010/10/29	DATE	
0	PLACE	+	---	+	---	---	---	---
SEE REVISION TABLE			ANGULAR ± 5 °		MATERIAL NO. 1111121009		DOCUMENT NO. SD-111112-1001	
IEC NO: CPG2016-1931 DRAWN BY: DRINKKE CHECKED BY: AJOHNSTON APPROVED BY: KJANOTA			DRAFT WHERE APPLICABLE MUST REMAIN WITHIN DIMENSIONS		DATE: 2010/04/23 DATE: 2010/04/23 DATE: 2010/10/29		TITLE: SFP/SFP+ 1X1 CAGE ACCESSORIES HEATSINK AND CLIP	

HEATSINK OPTIONS

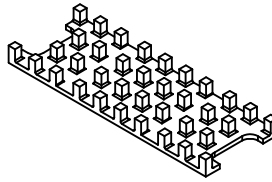
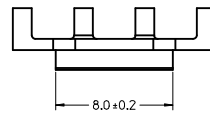
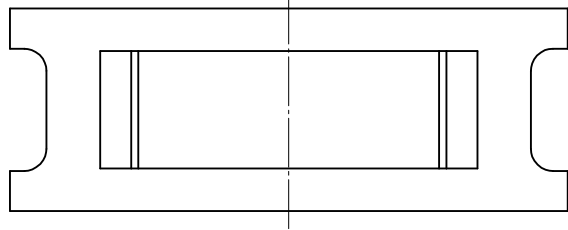
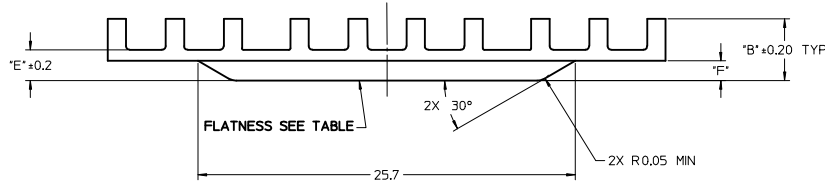
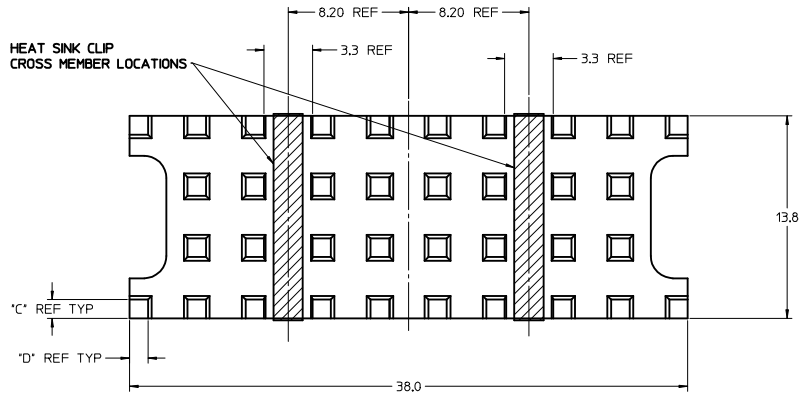

111112-2001

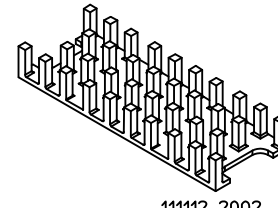

111112-2002

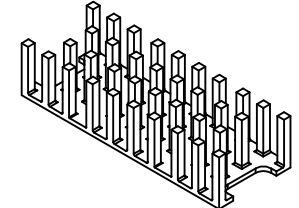

111112-2012

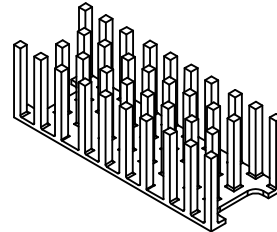

111112-2003

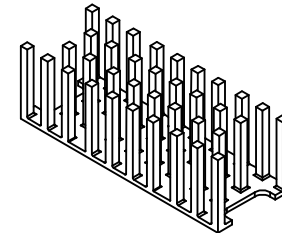

111112-2019

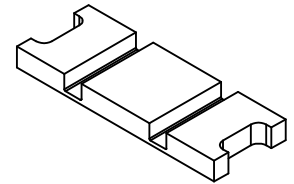

111112-2010

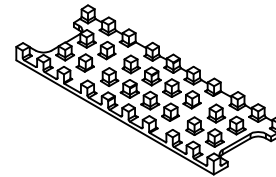

111112-2043

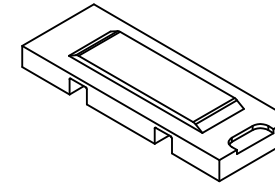

111112-2030 BOTTOM VIEW

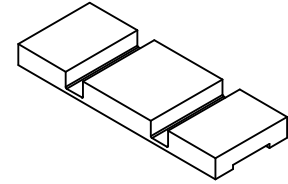

111112-2030

MATERIAL NO.	APPLICATION	DIMENSION *B*	DIMENSION *C*	DIMENSION *D*	DIMENSION *E*	DIMENSION *F*	FLATNESS
111112-2001	PCI	4.2	1.28	1.25	2.1	1.25 MIN	0.025
111112-2002	SAN	6.5	1.28	1.25	2.1	1.25 MIN	0.025
111112-2003	NETWORKING	13.5	1.28	1.25	2.1	1.25 MIN	0.025
111112-2010	SOLID BODY	4.4	N/A	N/A	1.65	0.9 REF	0.05
111112-2012	10mm TALL	10.0	1.28	1.25	2.1	1.25 MIN	0.025
111112-2019	NETWORKING	13.5	1.28	1.25	2.1	1.25 MIN	0.05
111112-2030	SOLID BODY	4.4	N/A	N/A	1.65	0.9 REF	0.05
111112-2043	CUSTOM	3.6	1.28	1.25	2.1	1.25 MIN	0.05

NOTES:

1. MATERIAL: ALUMINUM 6063
2. PLATING: NICKEL
3. NO RoHS EXEMPTIONS
4. INSPECTED TO MOLEX COSMETIC SPEC WI-HP-7-2774, CLASS B.

SEE REVISION TABLE EC NO: CPQ2016-1931 DRAWN BY: CHYKEMAN07 CHECKED BY: APPR:RCHEN08 DATE: 2015/11/09 DESCRIPTION:	QUALITY SYMBOLS	GENERAL TOLERANCES (UNLESS SPECIFIED)	DIMENSION STYLE	SCALE	DESIGN UNITS	THIRD ANGLE PROJECTION	
	∇=0 ∇=0 ∇=0	mm INCH 4 PLACES ± --- ± --- 3 PLACES ± 0.13 ± --- 2 PLACES ± 0.25 ± --- 1 PLACE ± --- ± --- 0 PLACE ± --- ± ---	MM ONLY	6:1	METRIC	DRAWN BY: ARI INKE DATE: 2010/04/23 CHECKED BY: AJOHNSTON DATE: 2010/04/23 APPROVED BY: KJANOTA DATE: 2010/10/29	TITLE: SFP/SFP+ 1X1 CAGE ACCESSORIES HEATSINK AND CLIP molex
	ANGULAR ± 5 ° DRAFT WHERE APPLICABLE MUST REMAIN WITHIN DIMENSIONS	MATERIAL NO.: SEE TABLE DOCUMENT NO.: SD-111112-1001	SHEET NO.: 2 OF 3	THIS DRAWING CONTAINS INFORMATION THAT IS PROPRIETARY TO MOLEX INCORPORATED AND SHOULD NOT BE USED WITHOUT WRITTEN PERMISSION			

DATE	REV	CHANGES
2010/04/23	A	INITIAL RELEASE
2012/07/20	B	COMPLETE REDESIGN TO ALSO WORK WITH SFP+ CAGES. ADDED HEATSINK INFORMATION FROM DRAWING SD-111112-2001.
2014/09/18	C	SHEET1: CHANGED *WM 3-D MODELS: EM-111112-1001, -2001, -2002, -2003, & -2012.* TO *MM 3-D MODEL: TM-111112-1001.* @M20. REMOVED *LEAD FREE* IN NOTE2 @B19 FOR NEW MOLEX PRINT POLICY (MATERIAL ISN'T CHANGED). SHEET2: REMOVED *LEAD FREE* IN NOTE3 @B19 FOR NEW MOLEX PRINT POLICY (MATERIAL ISN'T CHANGED). CHANGED 1.28 REF TYP TO *C* REF TYP. @ I19, 1.25 REF TYP TO *D* REF TYP @ I19, 2.1 ±0.2 @G19, <u>0.025</u> TO *FLATNESS SEE TABLE* @ F16, CHANGED 1.25 MM TO *F* @G12, ADDED 111112-2010 ISO VIEW @ F7 ; ADDED *111112-2010* & DIMENSION C, D, E, F, FLATNESS IN THE TABLE @D10.
2014/10/08	D	SHEET1: CHANGED MATERIAL NO. TO 1111121009.
2014/11/28	E	1. [SHEET 2] ADDED 111112-2019 VIEW @F3 2. [SHEET 2] ADDED 111112-2019 INTO MATERIAL NO. TABLE
2015/03/30	F	SHEET2: F3 ADDED 111112-2030 ISO VIEW AND BOTTOM VIEW D11 ADDED 111112-2030 INTO MATERIAL NO. TABLE
2015/08/11	G	SHEET2 : @G9 : ADDED 111112-2043 ISO VIEW @C11 : ADDED 111112-2043 INTO MATERIAL NO. TABLE

SEE REVISION TABLE IEC NO: CPG2016-1931 DRAWN BY: CHYKDEWANG07 APPR: RCHEN08 2015/08/11 2015/11/09 2015/11/09	QUALITY SYMBOLS	GENERAL TOLERANCES (UNLESS SPECIFIED)	DIMENSION STYLE	SCALE	DESIGN UNITS	THIRD ANGLE PROJECTION
	▽=0	4 PLACES ± mm INCH	MM ONLY	5:1	METRIC	☉
	▽=0	3 PLACES ± 0.13	DATE	TITLE		
	▽=0	2 PLACES ± 0.25	DATE	SFP/SFP+ 1X1 CAGE ACCESSORIES HEATSINK AND CLIP		
	0 PLACE ±	ANGULAR ± 5°	DATE	molex		
		DRAFT WHERE APPLICABLE MUST REMAIN WITHIN DIMENSIONS	DATE	DOCUMENT NO.		
			DATE	SD-111112-1001		
			DATE	SHEET NO.		
			DATE	3 OF 3		