

| |
|----------------|
| ADAPTER P/N |
| 106170-0523 |
| 106170-0533* |

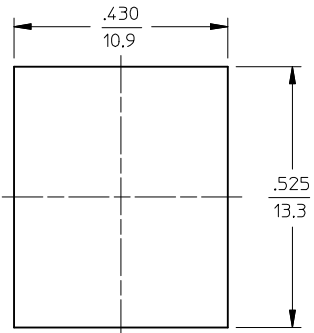

RECOMMENDED
MOUNTING HOLE

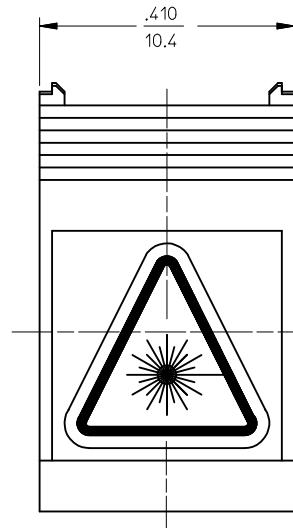

VIEW A

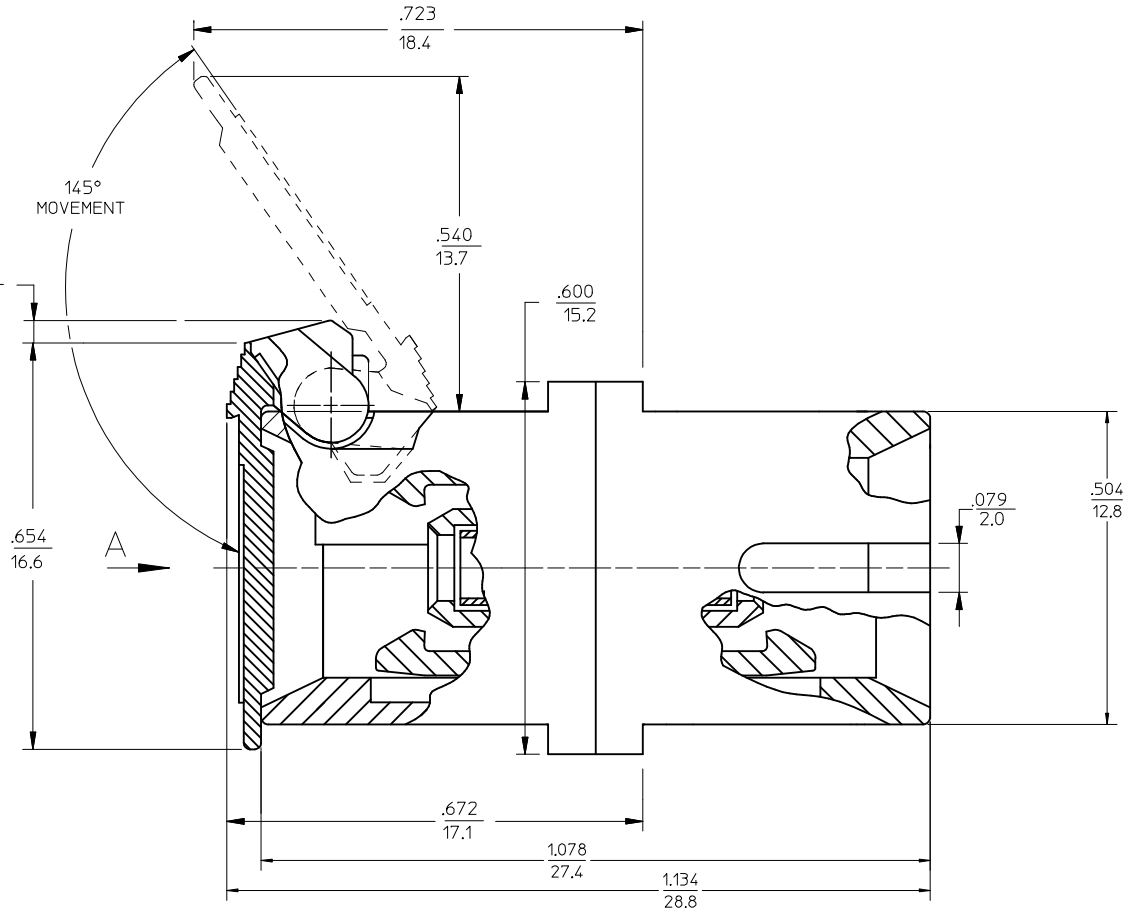

- NOTES:
- ALL DIMENSIONS ARE FOR REFERENCE ONLY.
 - LABEL IS INSTALLED AND ORIENTED AS SHOWN IN VIEW A .
 - DUST CAPS ARE NOT SHOWN BUT INCLUDED.
 - *4. P/N 106170-0533 IS BULK PACKED ADAPTER KIT OF 100 pcs.

| ENTER DESCRIPTION EC NO: MF2013-0749 DRWN: LGUMIN 2013/06/04 CHKD: APPR: LGUMIN 2013/06/12 REV B | QUALITY SYMBOLS ▽=0 ▽=0 | GENERAL TOLERANCES (UNLESS SPECIFIED) <table border="1"> <thead> <tr> <th></th> <th>mm</th> <th>INCH</th> </tr> </thead> <tbody> <tr> <td>4 PLACES</td> <td>±---</td> <td>±---</td> </tr> <tr> <td>3 PLACES</td> <td>±---</td> <td>±---</td> </tr> <tr> <td>2 PLACES</td> <td>±---</td> <td>±---</td> </tr> <tr> <td>1 PLACE</td> <td>±---</td> <td>±---</td> </tr> <tr> <td>0 PLACE</td> <td>±---</td> <td>±---</td> </tr> </tbody> </table> | | mm | INCH | 4 PLACES | ±--- | ±--- | 3 PLACES | ±--- | ±--- | 2 PLACES | ±--- | ±--- | 1 PLACE | ±--- | ±--- | 0 PLACE | ±--- | ±--- | DIMENSION STYLE IN/MM DRAWN BY: KP DATE: 2009/01/06 CHECKED BY: DATE: APPROVED BY: DATE: 2009/01/06 | SCALE: 5:1 DESIGN UNITS: INCH THIRD ANGLE PROJECTION | TITLE: SC ADAPTER W/SHIELD ZR SLV GREEN, W/LABEL NO CLIP molex | MATERIAL NO. SEE TABLE SIZE B | DOCUMENT NO. SD-106170-0523 | SHEET NO. 1 OF 1 |
|--|-------------------------------|--|---|----|------|----------|------|------|----------|------|------|----------|------|------|---------|------|------|---------|------|------|--|--|---|-------------------------------------|--------------------------------|---------------------|
| | | mm | INCH | | | | | | | | | | | | | | | | | | | | | | | |
| | 4 PLACES | ±--- | ±--- | | | | | | | | | | | | | | | | | | | | | | | |
| | 3 PLACES | ±--- | ±--- | | | | | | | | | | | | | | | | | | | | | | | |
| 2 PLACES | ±--- | ±--- | | | | | | | | | | | | | | | | | | | | | | | | |
| 1 PLACE | ±--- | ±--- | | | | | | | | | | | | | | | | | | | | | | | | |
| 0 PLACE | ±--- | ±--- | | | | | | | | | | | | | | | | | | | | | | | | |
| ANGULAR ±1/2° DRAFT WHERE APPLICABLE MUST REMAIN WITHIN DIMENSIONS | | | THIS DRAWING CONTAINS INFORMATION THAT IS PROPRIETARY TO MOLEX INCORPORATED AND SHOULD NOT BE USED WITHOUT WRITTEN PERMISSION | | | | | | | | | | | | | | | | | | | | | | | |