

V A R I O R

F O O T S W I T C H



- ▲ The Varior is a long lasting foot operated potentiometer switch with a robust steel housing. The rugged foot switch has an ergonomic design for ease of operation and is offered in an industrial version that has a heel rest for superior positioning of the foot on the pedal. The Varior is offered as a replacement switch for use on Miller®, Hobart®, Lincoln®, and ESAB® welding equipment. It is supplied with a 25 foot cordset, complete with a multi-pin connector that mates with your current equipment. Only from Linemaster - American made innovation at work.



LINEMASTER Switch Corporation
Tel (860) 974-1000

29 Plaine Hill Road, P.O. Box 238
Woodstock, Connecticut 06281-0238 USA
Fax (800) 974-FOOT(3668)

STANDARD VARIOR "09" SERIES

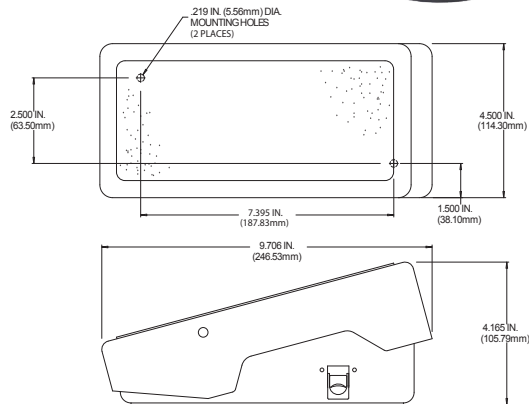

INDUSTRIAL VARIOR "OH" SERIES

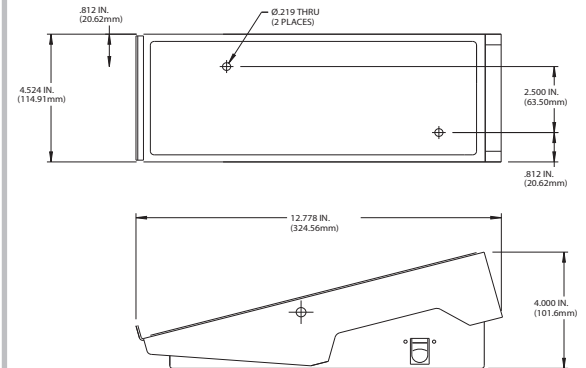

Features & Benefits:

- Retro-fits to most welding equipment
- 2 holes provided for rigid mounting to floor or equipment
- Heel rest offered in "OH" models
- Maximum resistance to be specified when ordering

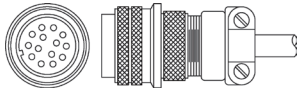

For Model: OHASAD
(ESAB®)

OHASAD-10K - Replaces ESAB® #FC-5B

- Complies with cRUUs requirements
- Complete with 30 ft. cord with 14 pin plug which mates to the power source
- Weight = 8.5 lbs.

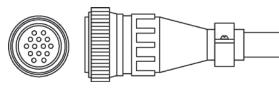

For Model: OHASAA
(Miller® and Hobart®)

OHASAA-1K - Replaces Miller® #RFCS-14 (#043-554) & Hobart® #043-554-01-01

- Complies with cRUUs requirements
- Complete with 25 ft. cord with 14 pin plug which mates to the power source
- Weight = 8.5 lbs.

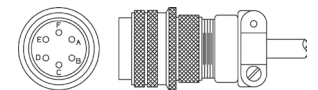

For Model: OHASAB
(Lincoln® Electric)

OHASAB-10K - Replaces Lincoln® #K-870

- Complies with cRUUs requirements
- Complete with 25 ft. cord with 6 pin plug which mates to the power source
- Weight = 8.5 lbs.

Agency Approvals	EN 60529 Degree of Protection	Catalog Number	Description	Cordset(s)
	IP20	09ASXP-xx ¹	Momentary	Supplied with a 6 ft. 18/4 cordset without plug. Wired three leads to potentiometer and green lead to ground
	IP20	09ARXU-xx ¹	Maintained	
	IP20	09ASAC-xx ¹	Momentary	Supplied with a 6 ft. 18/6 cordset without plug, with auxiliary switch set to operate at the beginning of treadle stroke and wired N.O. Three leads to the potentiometer and green lead to ground.
	IP20	09ARAC-xx ¹	Maintained	
	IP20	OHASAC-xx	Momentary	Supplied with 25' 18/6 cordset with 14 pin plug compatible with Hobart® & Miller®
	IP20	OHASAA-1K	Momentary	
	IP20	OHASAA-5KW	Momentary	Supplied with 25' 18/6 cordset with 14 pin plug compatible with Hobart® & Miller® (NOTE: Waterproof Potentiometer)
	IP20	OHASAB-10K	Momentary	Supplied with 25' 18/6 cordset with 6 pin plug compatible with Lincoln®
	IP20	OHASAD-10K	Momentary	Supplied with 25' 18/6 cordset with 14 pin plug compatible with ESAB®

¹ "xx" in Catalog Number to be potentiometer value in Ohms (i.e. 09ASXP-5K)