



DIN Signal female connector



General information

Design	IEC 60603-2	types: D, E female
No. of contacts	max. 48	
Contact spacing	5,08 mm	
Test voltage	1550V	
Contact resistance	max. 15mOhm	
Insulation resistance	min. 10 ⁹ Ohm	
Working current	6 A at 20°C (see derating diagram)	
Temperature range	-55°C ... +125°C -40°C ... +105°C for press-in connectors (due to limitations of PCB-material)	
Termination technology	solder pins, solder lugs, wirewrap, press-in	
Clearance	min. 3,0 mm	
Creepage	min. 3,0 mm	
Insertion and withdrawal force	32pole max. 50N 48pole max. 75N	
Mating cycles	- PL 1 acc. to IEC 60 603-2 => 500 mating cycles - PL 2 acc. to IEC 60 603-2 => 400 mating cycles - PL 3 acc. to IEC 60 603-2 => 50 mating cycles	
UL file	E102079	
RoHS - compliant	Yes	
Leadfree	Yes	
Hot plugging	No	

Insulator material

Material	PBT (thermoplastics, glass fiber reinforcement 30%)	
Color	RAL 7032 (grey)	
UL classification	UL 94-V0	
Material group acc. IEC 60664-1	IIIa (175 ≤ CTI < 400)	
NFF classification	I3, F4	

Contact material

Contact material	Copper alloy	
Plating termination zone	Sn over Ni for solder pins & lugs	Ni for wirewrap & press-in
Plating contact zone	Au over Ni	

Derating diagram acc. to IEC 60512-5 (Current carrying capacity)

The current carrying capacity is limited by maximum temperature of materials for inserts and contacts including terminals.

The current capacity curve is valid for continuous, non interrupted current loaded contacts of connectors when simultaneous power on all contacts is given, without exceeding the maximum temperature.

Control and test procedures according to DIN IEC 60512-5

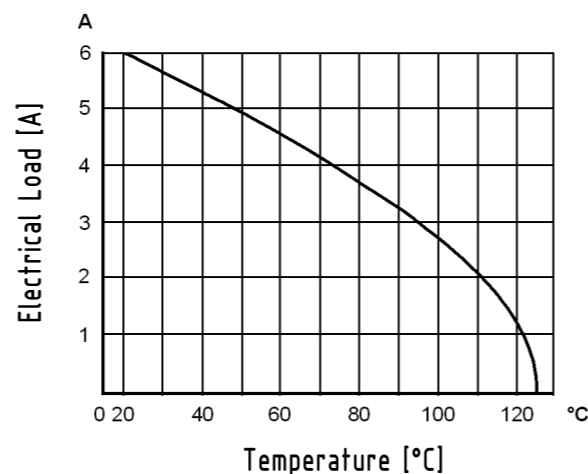

Recommended configuration of plated through holes for press-in termination

In addition to the hot-air-level (HAL), other PCB surfaces are getting more important. Due to their different properties - such as mechanical strength and coefficient of friction - we recommend the following configuration of PCB through holes.

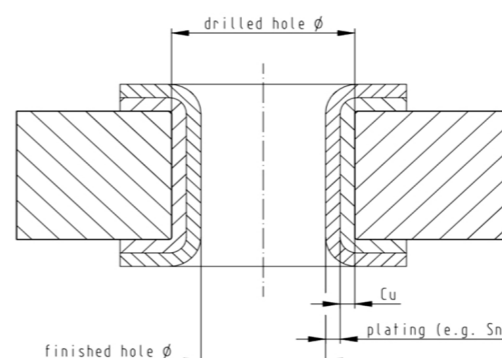

Plating Type	Drilled hole Ø	Plated hole Ø	Material	Thickness
Tin plated PCB (HAL) acc. to EN 60352-5	1,15±0,025 mm		Cu	min. 25 µm
		0,94 - 1,09 mm	Sn	max. 15 µm
Chemical tin plated PCB	1,15±0,025 mm		Cu	min. 25 µm
		1,00 - 1,10 mm	Sn	min. 0,8µm
Gold /Nickel plated PCB	1,15±0,025 mm		Cu	min. 25 µm
		1,00 - 1,10 mm	Ni	3 - 7 µm
Silver plated PCB	1,15±0,025 mm		Cu	min. 25 µm
		1,00 - 1,10 mm	Ag	0,1 - 0,3 µm
Copper plated PCB (OSP)	1,15±0,025 mm		Cu	min. 25 µm
		1,00 - 1,10 mm	Cu	min. 25 µm

Assembly instructions

It is highly recommended to use HARTING press-in tools to ensure a reliable press-in process. Please refer to the catalogue for tools, machines and further information about the press-in process.

Soldering instructions

The connectors should be protected when being soldered in a dip, flow or film soldering baths. Otherwise, they might become contaminated as a result of soldering operations or deformed as a result of overheating.

(1) For prototypes and short runs protect the connectors with an industrial adhesive tape, e.g. Tesaband 4331 (www.tesa.de). Cover the underside of the connector moulding and the adjacent parts of the pcb as well as the open sides of the connector. This will prevent heat and gases of the soldering apparatus from damaging the connector. About 140 + 5 mm of the tape should suffice.

(2) For large series a jig is recommended. Its protective cover with a fast action mechanical locking device shields the connectors from gas and heat generated by the soldering apparatus. As an additional protection a foil can be used for covering the parts that should not be soldered.

Cross section of solder pins

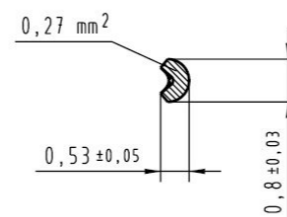

Cross section of wirewrap posts



	All Dimensions in mm Original Size DIN A3	Scale 1:1	Free size tol.	Ref. Sub. DS 09 04 210 00 01 / EC01557 / 28.04.11	
	All rights reserved Department EC PD - DE	Created by HAGEMEYERE	Inspected by TADJE	Standardisation HOFFMANN	Date 2014-08-11
HARTING Electronics GmbH D-32339 Espelkamp		Title DIN power female connector		State Final Release	
		Type DS	Number 09042100001	Doc-Key / ECM-Nr. 100580520/UGD/000/A 500000076067	Rev. A Page 1/1