

## Snap-on frame - CES-B10-SF-PLBK - 0801655

Please be informed that the data shown in this PDF Document is generated from our Online Catalog. Please find the complete data in the user's documentation. Our General Terms of Use for Downloads are valid (<http://phoenixcontact.com/download>)



Snap-on frame, type: B10, length: 108 mm, width: 64 mm, height: 39 mm, color: black

### Your advantages

- Can also be used for standard panel cutouts for heavy-duty industrial connectors

### Key Commercial Data

Packing unit	1 pc
GTIN	 4 046356 674157
GTIN	4046356674157
Weight per Piece (excluding packing)	52.000 g
Custom tariff number	39174000
Country of origin	Poland

### Technical data

#### Dimensions

Length	108 mm
Width	64 mm
Height	39 mm

#### Ambient conditions

Degree of protection	IP54
Ambient temperature (operation)	-20 °C ... 80 °C (static)

#### General

Frame type	Snap-on frame
------------	---------------

## Snap-on frame - CES-B10-SF-PLBK - 0801655

### Technical data

#### General

Material	PA (halogen-free)
Flammability rating according to UL 94	V0
Color	black
Note	Mounting screws not supplied as standard. The maximum width of the panel cutout must not exceed 51 mm (instead of 35 mm for heavy-duty industrial connectors).
Installation instructions	M4 mounting screw, 1.8 Nm torque.
	A video tutorial on how to assemble the product can be found in the Downloads area, in the Video category.

#### Standards and Regulations

Flammability rating according to UL 94	V0
--	----

#### Environmental Product Compliance

China RoHS	Environmentally friendly use period: unlimited = EFUP-e
	No hazardous substances above threshold values

### Drawings

# Snap-on frame - CES-B10-SF-PLBK - 0801655

Dimensional drawing

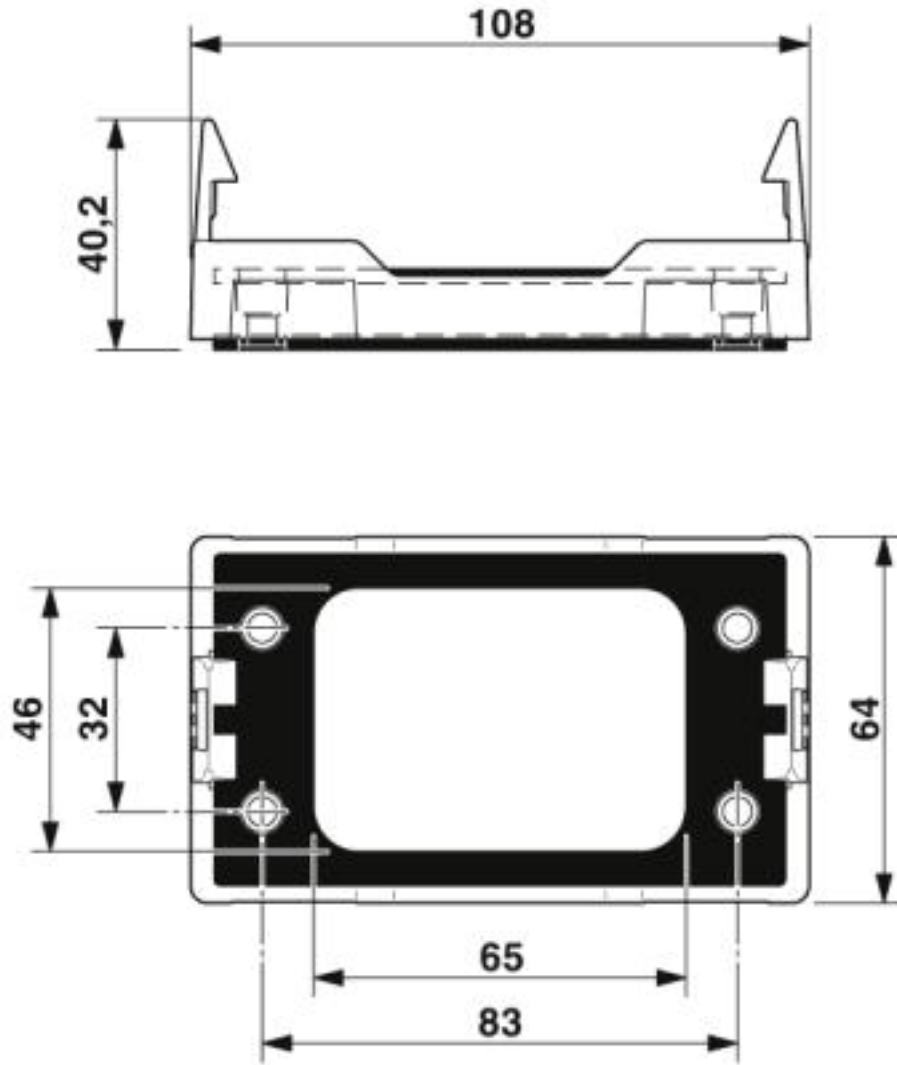

Dimensional drawing

# Snap-on frame - CES-B10-SF-PLBK - 0801655

Dimensional drawing

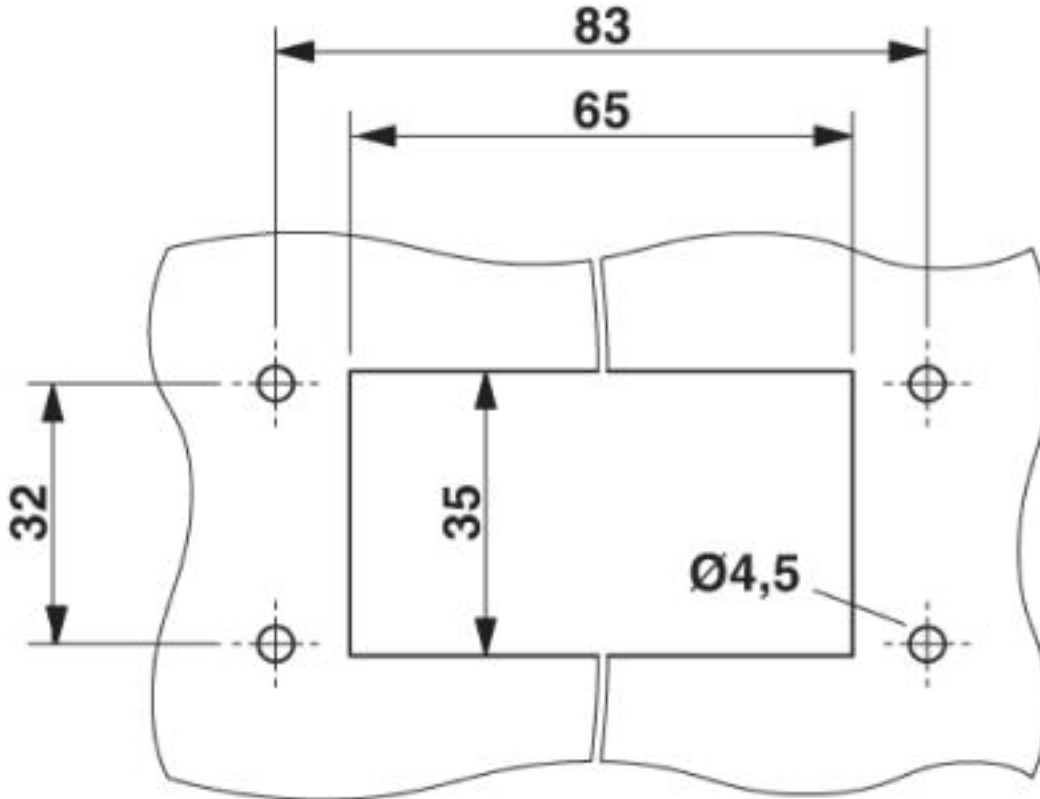

Mounting cutout

## Classifications

eCl@ss

eCl@ss 10.0.1	27440192
eCl@ss 4.0	27081000
eCl@ss 4.1	27081000
eCl@ss 5.0	27081000
eCl@ss 5.1	27081000
eCl@ss 6.0	27081000
eCl@ss 7.0	27069220
eCl@ss 8.0	27069220
eCl@ss 9.0	27440192

ETIM

ETIM 3.0	EC000451
----------	----------

# Snap-on frame - CES-B10-SF-PLBK - 0801655

## Classifications

### ETIM

ETIM 4.0	EC000451
ETIM 5.0	EC000451
ETIM 6.0	EC000451
ETIM 7.0	EC000451

### UNSPSC

UNSPSC 6.01	30212109
UNSPSC 7.0901	39121708
UNSPSC 11	39121708
UNSPSC 12.01	39121708
UNSPSC 13.2	39121448

## Approvals

### Approvals

---

Approvals

GL

---

Ex Approvals

---

### Approval details

GL		<a href="https://approvalfinder.dnvgi.com/">https://approvalfinder.dnvgi.com/</a>	1391415 HH
----	--	---	------------

## Accessories

### Accessories

#### Cover plate

Locking element - CES-B10-SFC-M-15,6 - 1423743



Locking element, type: B10, length: 100 mm, width: 57 mm, height: 17 mm

## Snap-on frame - CES-B10-SF-PLBK - 0801655

### Accessories

---

Frame for cable sleeves

Sealing frame - CES-B10-HFFS-PLBK - 0801663



Sealing frame with locking latch, size B10, with flat gasket, for 6 small sleeves

---

Sealing frame - CES-B10-SFFS-PLBK - 0801660



Sealing frame with screw locking, size B10, with flat gasket, for 6 small sleeves

---