

# Type 3AG / 3AP

## Fast Blow Fuse Series

HF  3AG/3AP Series, 6x32mm Glass Tube Fast Blow Fuse

RoHS 2 Compliant

### Description

6x32mm Fast Blow, glass tube body cartridge fuse designed, approved and complied with UL and CSA standard 248-14.

### Features

- Meet UL and CSA standard 248-14
- Wide operating temperature range
- Bulk packing available
- RoHS 2 compliant
- Halogen Free
- Lead Free

### Applications

Provide individual protection for components or internal circuits.



- Power supplies
- Battery charger
- Monitor
- Adapter

LEAD FREE = 

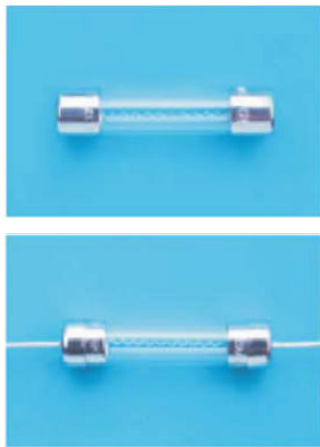
HALOGEN FREE = 





### Physical Specifications

Materials	Body : Ceramic
	Cap : Nickel Plated Brass Caps
	Leads : Matte Tin Plated Copper
Marking	On Fuse :
	"bel", "3AG", "Current Rating", "Voltage Rating", "Appropriate Safety Logos", "✓" ( RoHS 2compliant)
	On Label :
	"bel", "3AG"or"3AP", "Current Rating", "Voltage Rating", "Interrupting Rating", "Appropriate Safety Logos" and "✓", "  ", "  "(China RoHS compliant).

### Electrical Characteristics (UL/CSA STD.248-14)

Testing Current	Blow Time	
	Minimum	Maximum
100%	4 hrs.	N/A
135%	N/A	1 hr.
200%	N/A	5 sec

### Safety Agency Approvals



Safety Agency	Safety Agency Certificate	Voltage Rating (V)	Ampere Range / Volt @ I.R. ability*
	E20624	100mA-10A/ 250V AC	100mA-10A/250V AC@200A 100mA-15A/125V AC@10,000A
	LR39772		
	JET1037-31003-1010	12A-15A/ 125V AC	1A-5A/125V AC@500A >5A-15A/125V AC@300A
	JET1037-31003-1011		
	JET1037-31003-1007		

\*I.R.= Interrupting Rating = Short Circuit Rating(Amps)

## Environmental Specifications

Shock Resistance	MIL-STD-202G, Method 213B, Test Condition 1 (100 G's peak for 6 milliseconds; Sawtooth waveform)
Vibration Resistance	MIL-STD-202G, Method 201A (10-55 Hz, 0.06 inch, total excursion).
Salt Spray Resistance	MIL-STD-202G, Method 101E, Test Condition B (48 hrs).
Insulation Resistance	MIL-STD-202G, Method 302, Test Condition A (After Opening) 10,000 ohms minimum.
Solderability	MIL-STD-202G, Method 208H
Resistance to solder Heat	MIL-STD-202G, Method 210F, Test Condition B (260+/-5°C, 10+/-1 sec)
Thermal Shock	MIL-STD-202G, Method 107G, Test Condition B (-65°C to +125°C).
Operating Temperature	-55°C to +125°C
Terminal Strength	IEC-68-2-21

## Electrical Specifications

Catalog Number	Ampere Rating	Typical Cold Resistance (ohms)	Volt-drop @ 100%In (Volt) max.	Voltage and Interrupting Ratings	Melting I²T <10 mSec (A² Sec)	Melting I²T @10 In (A² Sec)	Maximum Power Dissipation (W)	Agency Approvals		
										
3AG(3AP) 100-R	100mA	11.3	4.62	See Table of Safety Approvals on Page 1 for Voltage and associated Interrupting Ratings	0.002	0.002	0.59	Y	Y	
3AG(3AP) 125-R	125mA	10.5	5.18		0.004	0.003	0.80	Y	Y	
3AG(3AP) 160-R	160mA	7.3	4.85		0.008	0.006	0.94	Y	Y	
3AG(3AP) 200-R	200mA	5.0	4.38		0.014	0.010	1.10	Y	Y	
3AG(3AP) 250-R	250mA	3.4	4.05		0.025	0.019	1.29	Y	Y	
3AG(3AP) 300-R	300mA	2.5	3.54		0.044	0.034	1.51	Y	Y	
3AG(3AP) 375-R	375mA	1.86	3.35		0.071	0.055	1.64	Y	Y	
3AG(3AP) 400-R	400mA	1.32	3.22		0.08	0.08	1.71	Y	Y	
3AG(3AP) 500-R	500mA	1.19	3.17		0.14	0.11	1.88	Y	Y	
3AG(3AP) 750-R	750mA	0.66	2.54		0.19	0.17	2.15	Y	Y	
3AG(3AP) 1-R	1A	0.155	0.28		1.4	1.4	0.37	Y	Y	Y
3AG(3AP) 1.25-R	1.25A	0.114	0.27		2.4	2.5	0.44	Y	Y	Y
3AG(3AP) 1.6-R	1.6A	0.085	0.27		4.2	4.4	0.51	Y	Y	Y
3AG(3AP) 2-R	2A	0.057	0.22		7.2	7.6	0.59	Y	Y	Y
3AG(3AP) 2.5-R	2.5A	0.043	0.21		12	13	0.70	Y	Y	Y
3AG(3AP) 3-R	3A	0.033	0.17		21	23	0.83	Y	Y	Y
3AG(3AP) 3.5-R	3.5A	0.027	0.18		28	31	0.91	Y	Y	Y
3AG(3AP) 4-R	4A	0.024	0.17		36	40	1.00	Y	Y	Y
3AG(3AP) 5-R	5A	0.018	0.16		63	70	1.20	Y	Y	Y
3AG(3AP) 6-R	6A	0.014	0.15		107	123	1.40	Y	Y	Y
3AG(3AP) 7-R	7A	0.012	0.16		141	162	1.60	Y	Y	Y
3AG(3AP) 8-R	8A	0.010	0.15		184	214	1.70	Y	Y	Y
3AG(3AP) 10-R	10A	0.008	0.13		316	372	2.00	Y	Y	Y
3AG(3AP) 12-R	12A	0.006	0.13		501	597	2.40	Y	Y	Y
3AG(3AP) 15-R	15A	0.006	0.15		845	1023	2.80	Y	Y	Y

Consult manufacturer for other ratings



Specifications subject to change without notice

Bel Fuse Inc.  
206 Van Vorst Street  
Jersey City, NJ 07302 USA

+1 201.432.0463  
Bel.US.CS@belf.com  
[belfuse.com/circuit-protection](http://belfuse.com/circuit-protection)

## Temperature Derating Curve

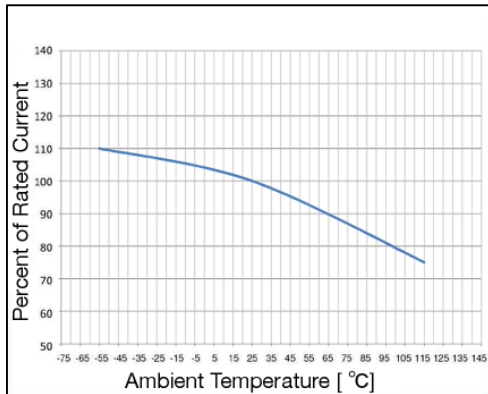

## Average Time Current Curve

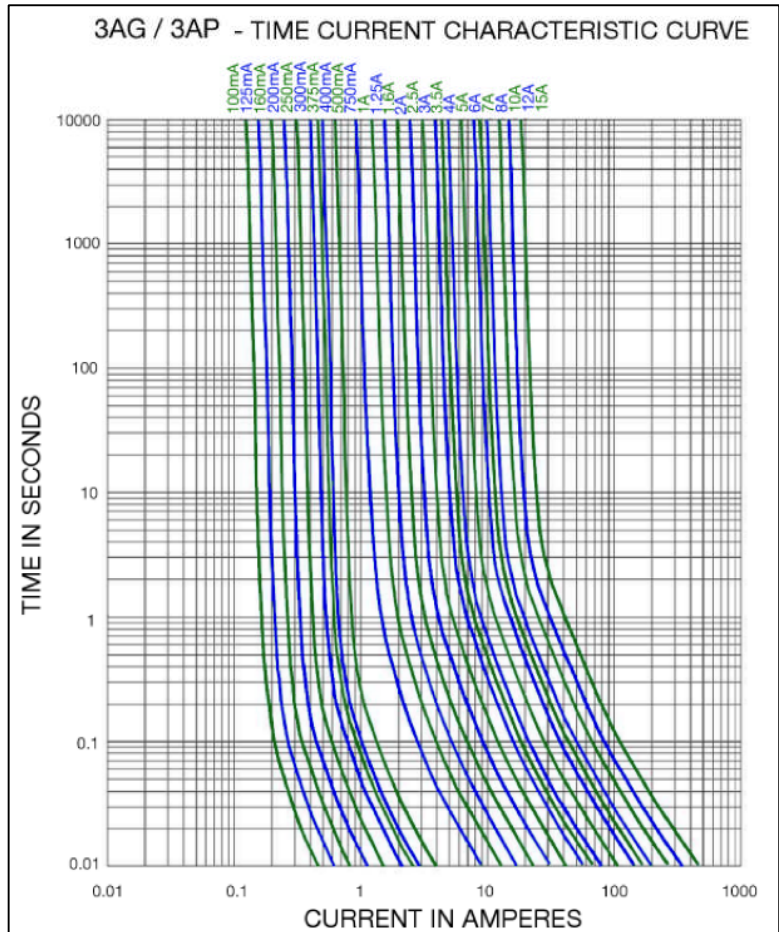

## Soldering Parameters

Lead-free Wave Soldering Profile	
Wave Soldering Parameter	
Average ramp-up rate	200°C / second
Heating rate during preheat	typical 1 - 2°C / second Max 4°C / second
Final preheat temperature	within 125°C of soldering temperature
Peak temperature T <sub>p</sub>	260°C
Time within +0°C / -5°C of actual peak temperature	10 seconds
Ramp-down rate	5°C / second max.

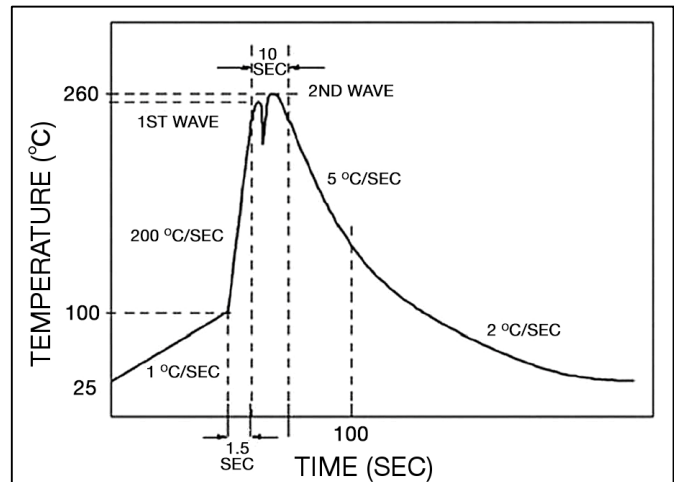

## Fuse FGNO Explanation

06X1 R [XXXX] -XX

0601R=3AG / 0611R=3AP; [XXXX]=Ampere Rating; XX=See Ordering Information as below

Fraction	Decimal	Milliamps	Bel FGNO[XXXX]
1/10	0.100	100	0100
1/8	.125	125	0125
	.160	160	0160
2/10	.200	200	0200
1/4	.250	250	0250
3/10	.300	300	0300
3/8	.375	375	0375
4/10	.400	400	0400
1/2	.500	500	0500
3/4	.750	750	0750

Fraction	Decimal	Amps	Bel FGNO[XXXX]
	1.0	1	1000
1-1/4	1.25	1.25	1250
	1.60	1.6	1600
	2.0	2	2000
2-1/2	2.5	2.5	2500
	3.0	3	3000
3-1/2	3.5	3.5	3500
	4.0	4	4000
	5.0	5	5000
	6.0	6	6000
	7.0	7	7000
	8.0	8	8000
		10	9100
		12	9120
		15	9150

## Mechanical Dimensions

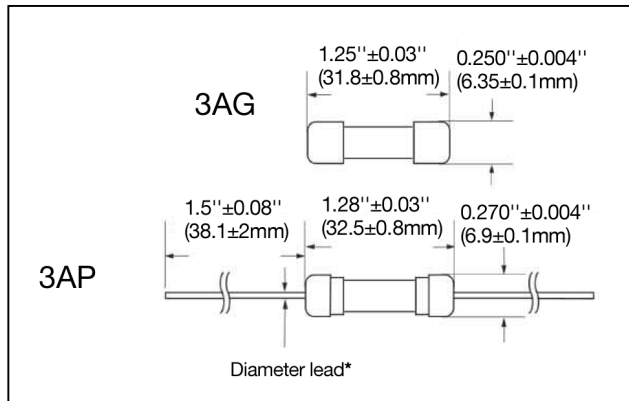

\*Ratings 7A and less have 0.032" diameter lead;  
Ratings 8A and above have 0.040" diameter lead.

## Ordering Information

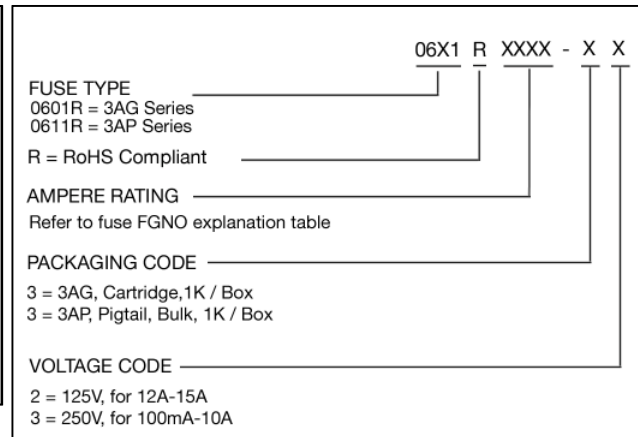

## Packaging

Packaging Option	Packaging Specification	Quantity	Packaging Code	Inside Tape Spacing
Bulk	N/A	1000	33 / 32	N/A
Bulk (Pigtail Type)	N/A	1000	33 / 32	N/A



Specifications subject to change without notice

**Bel Fuse Inc.**  
206 Van Vorst Street  
Jersey City, NJ 07302 USA

+1 201.432.0463  
Bel.US.CS@belf.com  
[belfuse.com/circuit-protection](http://belfuse.com/circuit-protection)